

# TB2

## Torque Reference Transducer



Standard version



Optional: degree of protection IP67

### Special features

- Accuracy class 0.03
- Nominal (rated) torques of 500 N·m, 1 kN·m, 2 kN·m, 3 kN·m, 5 kN·m and 10 kN·m
- High permissible vibration bandwidth
- In conjunction with DKD calibration certificate class 0.05 under DIN 51309 or EA-10/14
- Optional: degree of protection IP67 under EN 60529

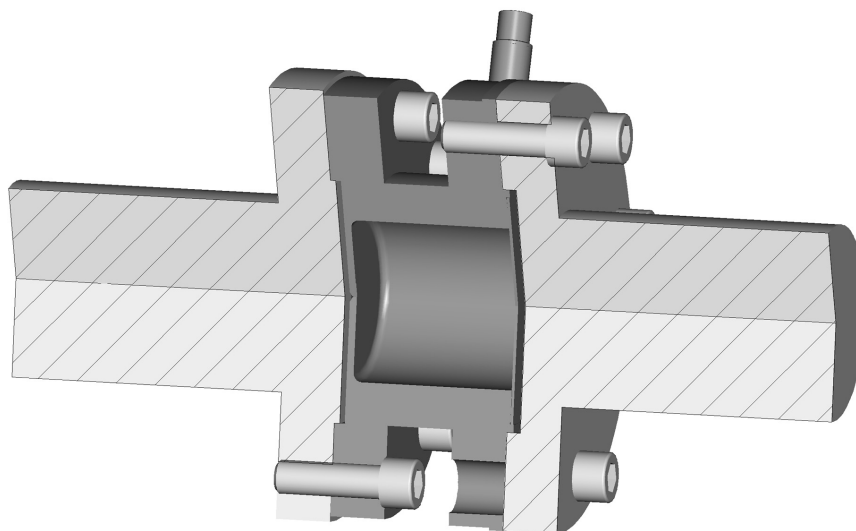

# Specifications

Type		TB2						
Accuracy class		0.03						
Nominal (rated) torque $M_{nom}$	N·m	500						
	kN·m		1	2	3	5	10	
Nominal (rated) sensitivity (spread between torque=zero and nominal (rated) torque)		mV/V	1					
Characteristic tolerance (deviation of the actual output at $M_{nom}$ of the nominal (rated) sensitivity)		%	< ±0.1					
Effect of temperature per 10 K in nominal (rated) temperature range		on the output signal, relative to the actual value	% < ±0.03					
		on the zero signal, relative to the nominal (rated) sensitivity	% < ±0.02					
Linearity deviation including hysteresis, relative to the nominal (rated) sensitivity		%	< ±0.03					
Relative standard deviation of repeatability under DIN 1319, relative to the variation of the output signal		%	< ±0.01					
Input resistance at reference temperature		Ω	1550 ± 100					
Output resistance at reference temperature		Ω	900 – 1500					
Reference excitation voltage		V	5					
Operating range of the excitation voltage		V	2.5 – 12					
Emission by (EN 61326–1, Table 4) RFI field strength			Class B					
Immunity from interference (EN 61326–1, Table A.1)								
Electromagnetic field (AM)		V/m	10					
Magnetic field		A/m	100					
Electrostatic discharge (ESD)								
Contact		kV	4					
Air		kV	8					
Burst (rapid transients)		kV	2					
Surge (impulse voltages)		kV	1					
Line-related interference		V	10					
Degree of protection under EN 60 529		–	IP54, optional IP67					
Nominal (rated) temperature range		°C	+10...+60					
Operating temperature range		°C	–10...+80					
Storage temperature range		°C	–20...+80					
Mechanical shock, degree of precision under DIN IEC 68; Part 2-27; IEC 68-2-27-1987								
Number		n	1000					
Duration		ms	3					
Acceleration (half-sine)		m/s <sup>2</sup>	650					
Vibrational stress								
Test severity level under DIN IEC 68, Part 2-27; IEC 68-2-6-1982								
Frequency range		Hz	5 – 65					
Duration		h	1.5					
Acceleration (amplitude)		m/s <sup>2</sup>	50					
Load limits <sup>1)</sup>								
Limit torque, relative to $M_{nom}$		%	200		160			
Breaking torque, relative to $M_{nom}$		%	>400		>320			
Axial limit force		kN	16	19	39	42	80	120
Lateral force limit		kN	4	5	9	10	12	18
Bending limit moment		N·m	200	220	560	600	800	1200
Vibration bandwidth under DIN 50 100 (peak-to-peak)		N·m	1000	2000	4000	4800	8000	16000

1) Each type of irregular stress (bending moment, lateral or axial load, exceeding nominal (rated) torque) can only be permitted up to its specified limit value provided none of the others can occur at the same time. If this condition is not met, the limit values must be reduced. If 30 % of the bending limit moment and lateral force limit occur at the same time, only 40 % of the axial limit force is permissible and nominal (rated) torque must not be exceeded. The permissible bending moments, longitudinal forces and lateral forces can affect the measurement result by approx. 0.2 % of nominal (rated) torque.

## Specifications

Mechanical values							
Nominal (rated) torque $M_{nom}$	N·m	500					
	kN·m		1	2	3	5	10
Torsional stiffness	kN·m/rad	540	900	2300	2600	4600	7900
Torsion angle at $M_{nom}$	Degree	0.055	0.066	0.049	0.066	0.06	0.07
Stiffness in the axial direction approx.	kN/mm	900	970	1000	1100	950	1600
Stiffness in the radial direction approx.	kN/mm	700	840	1400	1600	1400	2500
Stiffness during the bending moment round a radial axis	N·m/rad	165	170	380	390	550	1240
Maximum excursion at longitudinal force limit	mm	< 0.03		< 0.05		< 0.1	
Additional max. concentric error at lateral force limit	mm	< 0.01					
Additional in-plane deviation at bending moment limit	mm	< 0.04		< 0.06		< 0.1	
Mass moment of inertia (not taking flange screws into account) of rotor $I_v$ (around longitudinal axis)	kg·m <sup>2</sup>	0.0059		0.0192		0.037	0.097
Position of the S.G. level (as distance to the flange adaptation surface level with external centering)	% of the overall length	50					
Mass moment of inertia as a percentage (sensor side)	%	57		55		54	
Weight, approx. (without cable)	kg	2.4		4.9		8.3	14.6
Weight IP67-version, approx. (with cable)	kg	2.6		5.1		8.5	14.8

Supplementary information under DIN 51309 or EA-10/14		
Class under DIN 51309 or EA-10/14		0.05
Rel. zero error (zero signal return)	%	< ± 0.008 (typically < 0.003)
Rel. spread ( $0.1 \cdot M_{nom}$ to $M_{nom}$ ) with	unmodified mounting position	< 0.02 (typically < 0.01)
	with modified mounting position	< 0.03 (typically < 0.02)
Relative reversibility error ( $0.1 \cdot M_{nom}$ to $M_{nom}$ )	%	< 0.06 (typically < 0.03)

### Scope of supply:

TB2

Transducer connection cable, 3 m, (Lemo® FGG6 pigtails)

Test report

Mounting Instructions

### Option:

Degree of protection IP67 under EN 60529

Order no.: D-TB2/IP67

### Accessories:

Connector MS 3106PEMV, fitted to cable

Order no.: D-MS/MONT

15-pin D-Sub connector (male), fitted to cable

Order no.: D-15D/MONT

DKD calibration certificate under DIN 51309 or EA 10-4

# Standard version

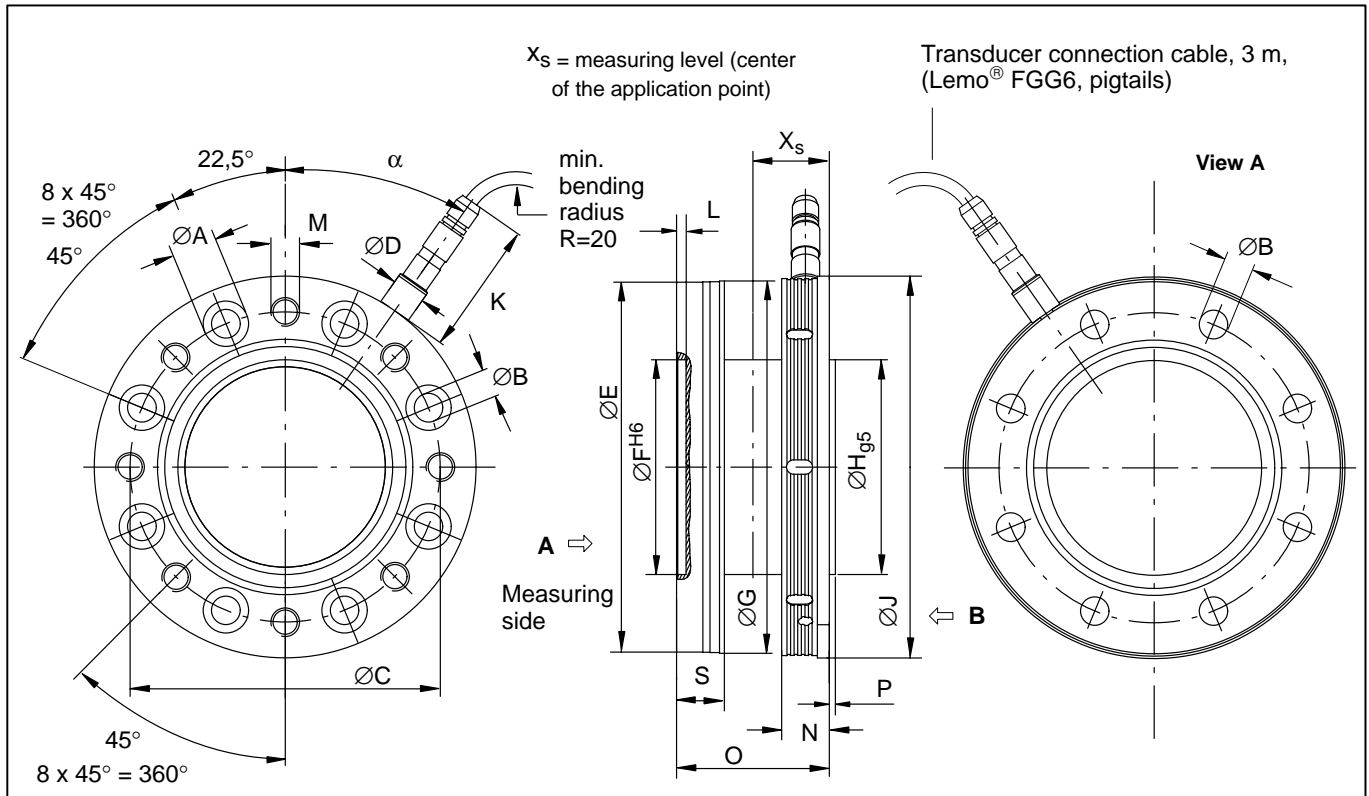

Nominal (rated) torque	$\varnothing A$	$\varnothing B$	$\varnothing C$	$\varnothing D$	$\varnothing E$	$\varnothing FH6$	$\varnothing G$	$\varnothing H_{g5}$	$\varnothing J$	K	$\alpha$	M	S	L	N	O	P	$X_s$
500 N·m – 1 kN·m	17	10	101.5	14	120	75	121	75	124	57	35.8	M10	18	4	18	60	2 <sup>+0.4</sup>	30
2 kN·m – 3 kN·m	19	12	130	14	155	90	156	90	160	57	35	M12	20	4	20	64	2.5 <sup>+0.4</sup>	32
5 kN·m	22	14.2	155.5	14	179	110	180	110	188	57	10	M14	26	3	26	84	2.8	42
10 kN·m	26	17	196	14	221	140	222	140	230	57	10	M16	30	4	30	92	3.5 <sup>+0.5</sup>	46

**Option: degree of protection IP67**

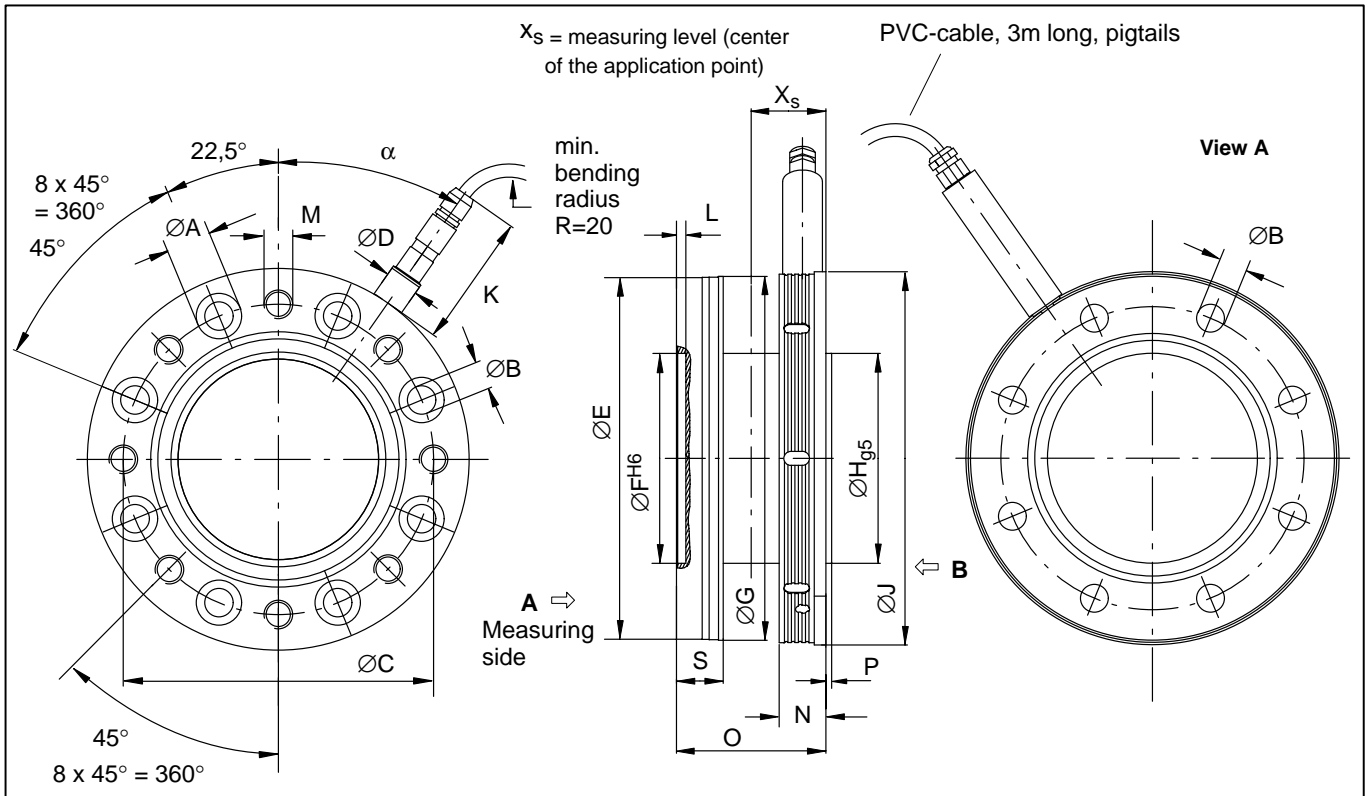

Nominal (rated) torque	ØA	ØB	ØC	ØD	ØE	ØFH6	ØG	ØHg5	ØJ	K	α	M	S	L	N	O	P	Xs
500 N·m – 1 kN·m	17	10	101.5	17	120	75	121	75	124	80	35.8	M10	18	4	18	60	2 <sup>+0.4</sup>	30
2 kN·m – 3 kN·m	19	12	130	17	155	90	156	90	160	80	35	M12	20	4	20	64	2.5 <sup>+0.4</sup>	32
5 kN·m	22	14.2	155.5	17	179	110	180	110	188	80	10	M14	26	3	26	84	2.8	42
10 kN·m	26	17	196	17	221	140	222	140	230	80	10	M16	30	4	30	92	3.5 <sup>+0.5</sup>	46

**Circular run-out values**

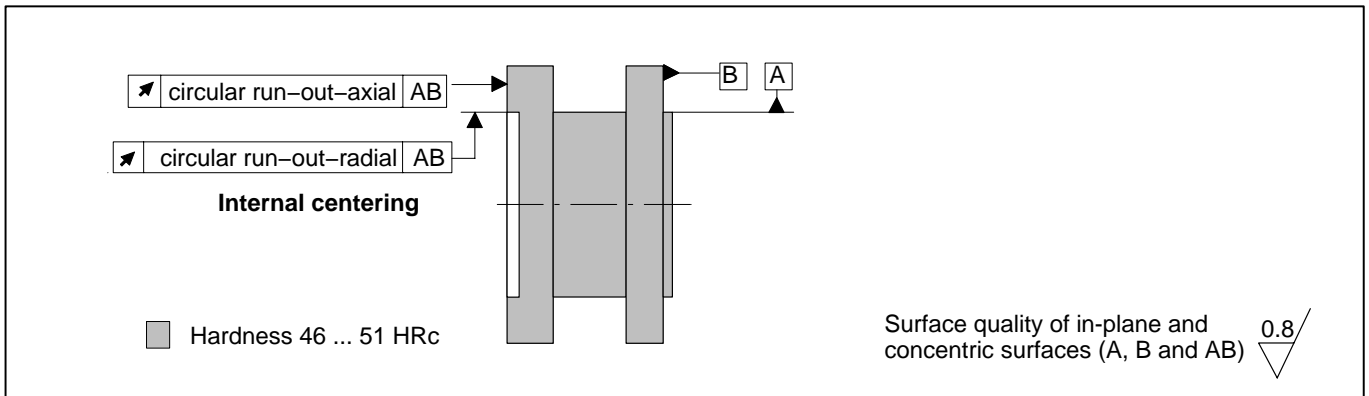

Measuring range	Circular run-out-axial tolerance (mm)	Circular run-out-radial tolerance (mm)
500 N·m	0.01	0.01
1 kN·m	0.01	0.01
2 kN·m	0.02	0.02
3 kN·m	0.02	0.02
5 kN·m	0.02	0.02
10 kN·m	0.02	0.02

Modifications reserved.  
All details describe our products in general form only. They  
are not to be understood as express warranty and do not  
constitute any liability whatsoever.

B0873-2.0 en

**Hottinger Baldwin Messtechnik GmbH**

Im Tiefen See 45, D-64293 Darmstadt, Germany  
Tel.: +49 6151 8030; Fax: +49 6151 803 9100  
E-mail: [support@hbm.com](mailto:support@hbm.com) [www.hbm.com](http://www.hbm.com)



measurement with confidence