

# Mounting Instructions

## Torque Transducer

### T5





---

| <b>Contents</b>                               | <b>Page</b> |
|---|-------------|
| <b>Safety instructions</b> .....              | <b>4</b>    |
| <b>1 Measuring characteristics</b> .....      | <b>7</b>    |
| <b>2 Mounting</b> .....                       | <b>7</b>    |
| 2.1 Mounting position .....                   | 7           |
| 2.2 Fastening the housing .....               | 8           |
| 2.3 Load capability .....                     | 8           |
| <b>3 Measurement of dynamic torques</b> ..... | <b>9</b>    |
| <b>4 Protective precaution</b> .....          | <b>10</b>   |
| <b>5 Maintenance and servicing</b> .....      | <b>10</b>   |
| <b>6 Electrical connection</b> .....          | <b>11</b>   |
| 6.1 General instructions .....                | 11          |
| <b>7 Accessories</b> .....                    | <b>12</b>   |
| <b>8 Specifications</b> .....                 | <b>13</b>   |
| <b>9 Dimensions</b> .....                     | <b>14</b>   |

## Safety instructions

### Appropriate use

The T5 Torque Flange may be used for torque-measurement and directly related control and regulation tasks, only. Any other use is not appropriate.

To ensure safe operation, the transducer may only be used according to the specifications given in this manual. When using the transducer, the legal and safety regulations for the respective application must also be observed. The same applies if accessories are used.

The transducer is no safety element in the sense of appropriate use. Prerequisites for correct and safe transducer operation are appropriate transportation, storage, installation and mounting, and careful operation.

### General dangers in the case of non-observance of the safety instructions

The transducer complies with the state of the art and is operationally reliable. If the transducer is used and operated inappropriately by untrained personnel, residual dangers might develop.

Any person charged with transducer installation, operation, maintenance or repair must in any case have read and understood the operating manual and the notes on safety, in particular.

### Residual dangers

The transducer's scope of performance and supply covers a part of the torque measuring-technology, only. The plant designer/constructor/operator must in addition design, realise and take responsibility for the torque measuring-system's safety such that potential residual dangers are minimized. The respective regulations must in any case be observed. Residual dangers regarding the torque measuring-system must be specified explicitly.

In this manual, the below symbols are used to refer to residual dangers:

Symbol:  **DANGER**  
Meaning: **Maximum danger level**  
Warns of an **imminently** dangerous situation in which failure to comply with safety requirements **will** result in death or serious physical injury.

Symbol:  **WARNING**  
Meaning: **Dangerous situation**  
Warns of a **potentially** dangerous situation in which failure to comply with safety requirements **can** result in death or serious physical injury.

Symbol:  **CAUTION**  
Meaning: **Potentially dangerous situation**  
Warns of a **potentially** dangerous situation in which failure to comply with safety requirements **could** result in damage to property or some form of physical injury.

Symbols indicating application notes and useful information:

Symbol:  **NOTE**  
Means that important information about the product or its handling is being given.

Symbol: **CE**  
Meaning: **CE mark**  
The CE mark enables the manufacturer to guarantee that the product complies with the requirements of the relevant EC directives (see Declaration of Conformity at the end of this document).

## **Reconstruction and modifications**

HBM's express consent is required for modifications regarding the transducer's construction and safety. HBM does not take responsibility for damage resulting from unauthorized modifications.

## **Qualified personnel**

The transducer may be used by qualified personnel, only; the technical data and the special safety regulations must in any case be observed. When using the transducer, the legal and safety regulations for the respective application must also be observed. The same applies if accessories are used.

Qualified personnel means: personnel familiar with the installation, mounting, start-up and operation of the product, and trained according to their job.

## **Prevention of accidents**

According to the prevailing regulation to prevent accidents a cover has to be fitted after the mounting of the torque transducer as follows:

- The cover or cladding must not be free to rotate.
- the cover shall avoid any danger of squeezing and provide protection against parts that might come loose
- Covers and cladding must be positioned at a suitable distance or so arranged that it prevents access to any moving parts within.
- Covers and cladding must also be attached if the moving parts of the torque flange are installed outside peoples' movement and operating range.

The only permitted exceptions to the above requirements are if the various parts and assemblies of the machine are already fully protected by the design of the machine or by existing safety precautions.

## **Warranty**

In the case of complaints, a warranty can only be given if the torque transducer is returned in the original packaging.

## 1 Measuring characteristics

- Strain gauge measuring system
- Sensitivity 2 mV/V
- Rated supply voltage 0.5 V ... 12 V
- Input resistance 350  $\Omega$

## 2 Mounting

### 2.1 Mounting position

The torque transducers may be mounted in any position. In the case of horizontal mounting, make sure that the installed flanged plug is not pointed downwards. The transfer of the torque is by frictional joints at the both ends of the shaft.

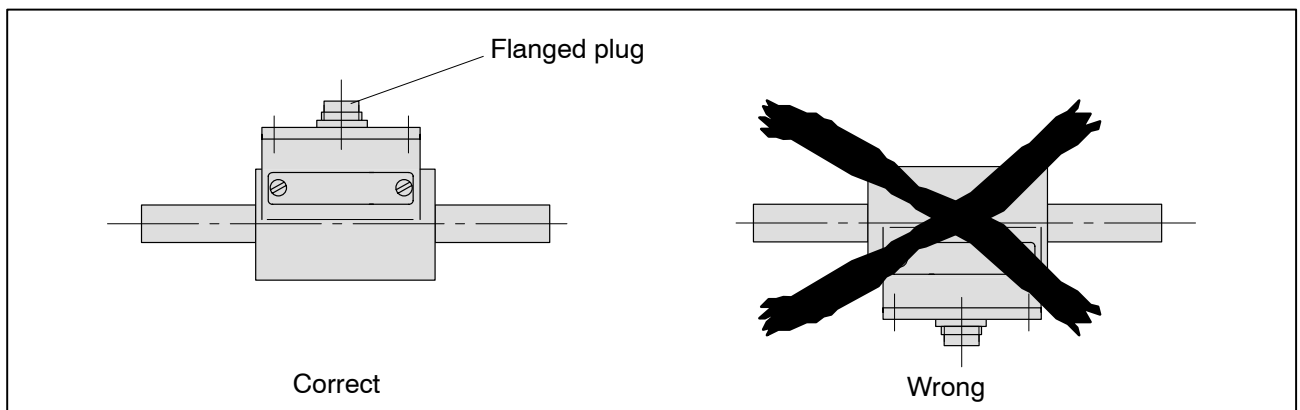

**Fig.2.1:** Correct mounting position in the case of horizontal mounting

## 2.2 Fastening the housing

The torque transducers have very little bearing friction. Therefore, it is sufficient to secure the housing against co-rotation. For this purpose, there is an M4 threaded bore in the housing (see Fig.2.2) into which an appropriate stop (e.g. a threaded rod) can be screwed. The transducers with measuring ranges of 100 N·m and 200 N·m have no such threaded bore. Here, one of the screws of the lateral inspection aperture has to be loosened or removed (M3, max. 5 mm depth of thread) in order to fasten a ring or a threaded rod (dimensions see chapter 9).

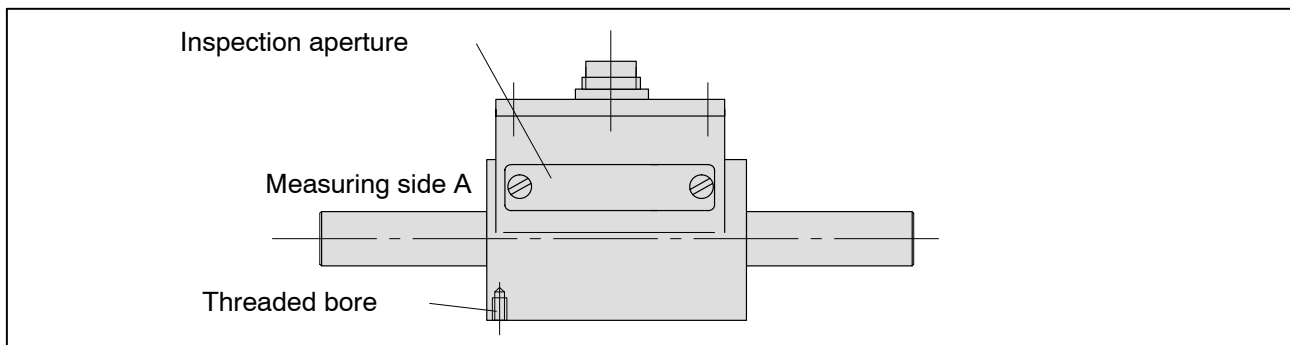

**Fig.2.2:** How to fasten the housing

## 2.3 Load capability

The nominal (rated) torques may be statically exceeded by max. 50 %. If the nominal (rated) torque is exceeded, additional irregular loading is not permissible; this refers to longitudinal forces, lateral forces and bending moments. See the chapter on "Specifications" for the respective limit values.

### 3 Measurement of dynamic torques

The T5 Torque Transducer are suitable for measuring static and dynamic torques.

When measuring dynamic torques, remember that:

- The calibration carried out for static torques also applies to dynamic torque measurements.
- The natural frequency  $f_0$  of the mechanical measuring installation depends on the moments of inertia  $J_1$  and  $J_2$  of the coupled rotating masses and the torsional stiffness of the torque transducer.

The natural frequency  $f_0$  of the mechanical measurement arrangement can be determined by the following equation:

$$f_0 = \frac{1}{2 \cdot \pi} \cdot \sqrt{C_T \cdot \left( \frac{1}{J_1} + \frac{1}{J_2} \right)}$$

$f_0$  = Natural frequency in Hz

$C_T$  = Torsional stiffness in N·m/rad

$J_{1,2}$  = Moment of inertia in N·m·s<sup>2</sup> (= kg·m<sup>2</sup>)

- The amplitudes (peak-to-peak) must never exceed 70 % of the nominal (rated) torque for the specific type, even with oscillating torque. In all cases the amplitudes must lie within the load range limits of  $-M_N$  and  $+M_N$ .

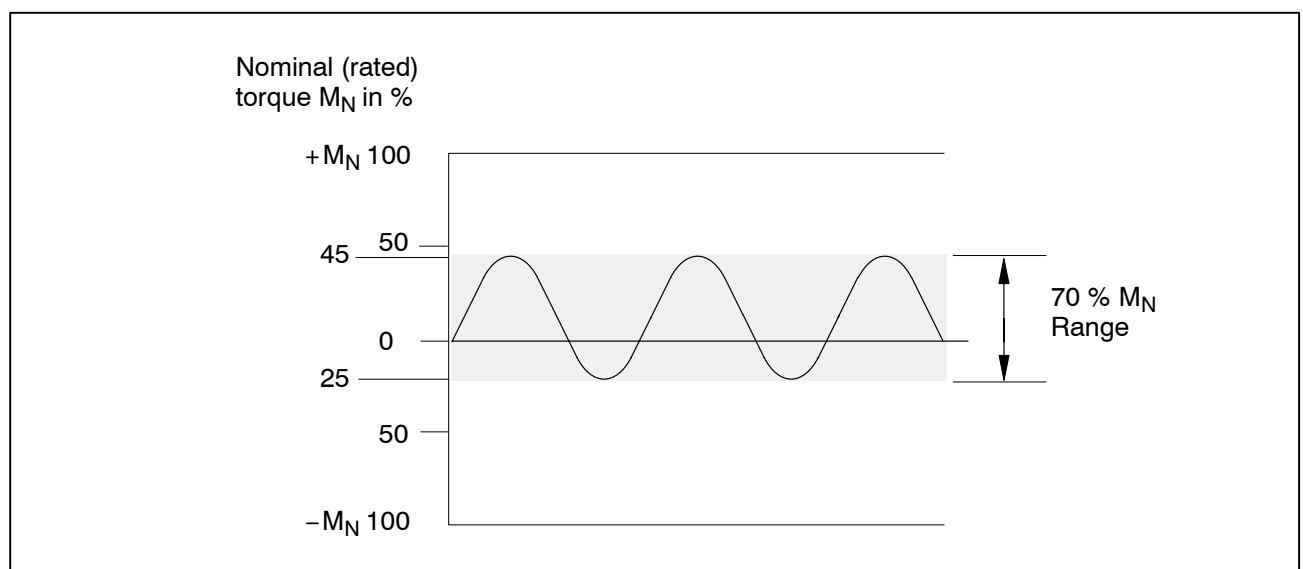

**Fig.2.3:** Amplitudes of dynamic load

## 4 Protective precaution

The torque transducers T5 are designed in protection class IP50 to EN 60 529. Protect the transducers against coarse dirt, dust, oil and moisture.

## 5 Maintenance and servicing

The torque transducer T5 are to a large extent designed to be maintenance free. Only the sliprings and carbon brushes are subject to slight wear, which must be monitored.

For reasons of functional safety, the carbon brush dust should be removed from the housing of the transducer (see Tab.5.1). To do this, remove the cover screwed on at the side and carefully remove the carbon dust or dirt present using a fine brush and dry compressed air.

Replacement of the carbon brushes can only be carried out in the factory at Darmstadt.

| T5<br>Nominal (rated) torque<br>[N·m] | Service life of brushes,<br>approx.<br>[revolutions] | Removal of carbon dust<br>after:<br>[revolutions] |
|---------------------------------------|--|---|
| 10; 20; 50; 100; 200                  | $3 \times 10^8$                                      | $1 \times 10^7$                                   |

**Tab.5.1:** Service life of the brushes

Please note that the service interval is shortened for increasing operating speed!

*Example:*

Speed 4000 rpm 

*Removal of brush dust after approx.  
42 hours*

Speed 1500 rpm 

*Removal of brush dust after approx.  
111 hours*

## 6 Electrical connection

### 6.1 General instructions

We recommend to use shielded, low-capacitance cable from HBM for the electrical connection between torque transducer and measuring amplifier.

With cable extensions it is important to ensure that a good connection is provided, with minimum contact resistance and good insulation. All plug connections or cap nuts have to be tightened firmly.

Do not route measurement cables in parallel to power lines and control circuits. If this is not possible (for example in cable ducts), maintain a minimum distance of 50 cm and protect the cable with a steel tube.

Avoid transformers, motors, contactors, thyristor controllers and similar sources of stray fields.

The transducers have been equipped with a permanently mounted housing plug. Use the Kab 139A-6 (accessories) HBM connection cable to connect the transducers to the measuring electronics.

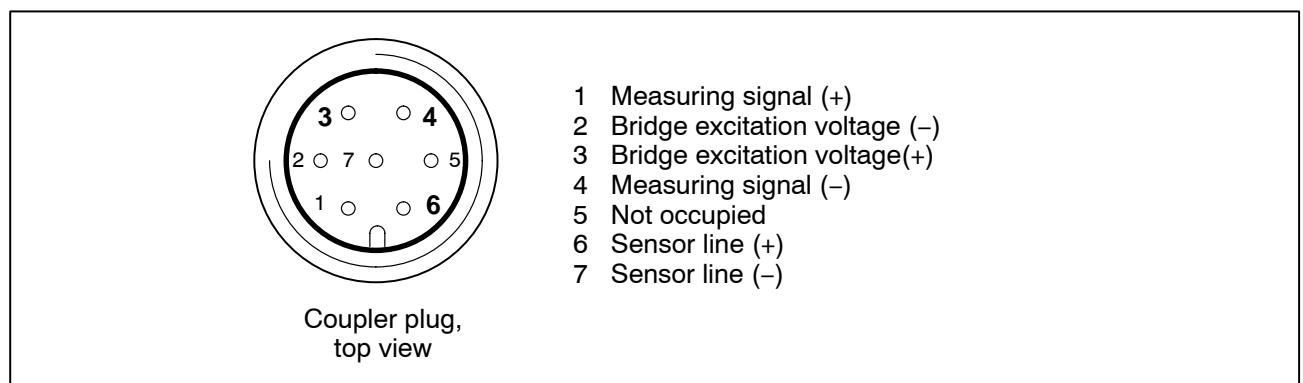

**Fig.6.1:** Plug pin allocation

The cable screen is connected according to the HBM Greenline concept, thus enclosing the measuring system (without rotor) in a Faraday cage and preventing potential electromagnetic interferences from affecting the measuring signal. Special electronic coding methods are used to protect the transmission path and the rotor from electromagnetic interferences.

In the case of interferences due to potential differences (compensating currents), operating-voltage zero and housing ground must be disconnected on the amplifier and a potential-equilibration line between stator housing and amplifier housing must be established (highly flexible strand, 10 mm<sup>2</sup> wire cross-section). For correct measurement, the rotor (e.g. via a ground slip-ring) and the stator must be earthed.

## 7 Accessories

To be ordered separately:

| <b>Connection cable</b>     | <b>Length (m)</b> | <b>Lead connection</b>                      |
|-----------------------------|-------------------|---|
| Kab 139A-6                  | 6                 | Binder 423 – free ends (Greenline)          |
| <b>Cable extension</b>      |                   |   |
| Kab 0304A-10                | 10                | 7-pin MS socket – 7-pin MS plug (Greenline) |
| Kab 8/00-6GY/3x2Cx0,14C-PVC | min. 10           | cut to length                               |

## 8 Specifications

| Type  | T5                                  |                            |     |       |     |     |
|---|-------------------------------------|----------------------------|-----|-------|-----|-----|
| <b>Accuracy class</b>   | 0.1                                 |                            |     |       |     |     |
| <b>Nominal (rated) torque</b>   | N·m                                 | 10                         | 20  | 50    | 100 | 200 |
| <b>Nominal (rated) sensitivity</b> (nominal (rated) output signal at nominal (rated) torque)                        | mV/V                                | 2                          |     |       |     |     |
| <b>Sensitivity tolerance</b>  | %                                   | < ±0.2                     |     |       |     |     |
| <b>Temperature effect per 10 K in the nominal (rated) temperature range</b>   |                                     |                            |     |       |     |     |
| On output signal (related to actual value)  | %                                   | < ±0.1                     |     |       |     |     |
| On zero signal (related to nominal (rated) sensitivity)   | %                                   | < ±0.1                     |     |       |     |     |
| <b>Linearity deviation, including hysteresis</b> , related to nominal (rated) sensitivity                           | %                                   | < ±0.1                     |     |       |     |     |
| <b>Relative standard deviation of reproducibility according to DIN 1319</b> (related to variation of output signal) | %                                   | < ±0.05                    |     |       |     |     |
| <b>Input resistance at reference temperature</b>  | Ω                                   | 350 ± 1.8                  |     |       |     |     |
| <b>Output resistance at the reference temperature</b>   | Ω                                   | 350 ± 1.5                  |     |       |     |     |
| <b>Maximum permissible excitation voltage</b>   | V                                   | 20                         |     |       |     |     |
| <b>Nominal (rated) range of the excitation voltage</b>  | V                                   | 0.5 ... 12                 |     |       |     |     |
| <b>Reference temperature</b>  | °C [°F]                             | +23 [+73.4]                |     |       |     |     |
| <b>Nominal (rated) temperature range</b>  | °C [°F]                             | +10 ... +60 [+50 ... +140] |     |       |     |     |
| <b>Service temperature range</b>  | °C [°F]                             | -10 ... +60 [+14 ... +140] |     |       |     |     |
| <b>Storage temperature range</b>  | °C [°F]                             | -50 ... +70 [-13 ... +158] |     |       |     |     |
| <b>Mechanical values</b> (related to nominal (rated) torque)  |                                     |                            |     |       |     |     |
| <b>Static limit load</b>  | %                                   | 150                        |     |       |     |     |
| <b>Static breaking load</b>   | %                                   | 300                        |     |       |     |     |
| <b>Limit bending moment<sup>1)</sup></b>  | N·m                                 | 1.2                        | 2.3 | 6     | 11  | 23  |
| <b>Limit lengthwise force<sup>1)</sup></b>  | kN                                  | 0.6                        | 1.9 | 3.5   | 5.5 | 8.8 |
| <b>Limit transverse force<sup>1)</sup></b>  | N                                   | 9                          | 26  | 50    | 80  | 125 |
| <b>Torsion angle at nominal (rated) torque, approx.</b>   | degrees                             | 0.85                       |     |       |     |     |
| <b>Moment of inertia</b>  | kgm <sup>2</sup> · 10 <sup>-3</sup> | 0.041                      |     | 0.047 |     |     |
| <b>Maximum permissible speed</b>  | rpm                                 | 4000                       |     |       |     |     |
| <b>Service life of the slipping system, approx.</b>   | revol.                              | 3x10 <sup>8</sup>          |     |       |     |     |
| <b>Vibration amplitude to ISO/R 373</b> (related to the nominal (rated) torque M <sub>N</sub> ) <sup>2)</sup>       | %                                   | 70 (Peak-to-peak)          |     |       |     |     |

<sup>1)</sup> Each type of irregular stress can only be permitted with its given limit value (bending moment, side load or axial load, exceeding the nominal (rated) speed) if none of the others can occur. Otherwise the limit values must be reduced. If for instance 30 % of the bending moment and also 30 % of the side load are present, only 40 % of the axial load are permitted, provided that the nominal (rated) torque is not exceeded. With maximum additional loading, measuring errors of the order of 1 % of the nominal (rated) torque can occur.

<sup>2)</sup> The nominal (rated) torque must not then be exceeded.

|   |                             |          |     |    |     |     |
|---|-----------------------------|----------|-----|----|-----|-----|
| <b>Nominal (rated) torque</b>   | N·m                         | 10       | 20  | 50 | 100 | 200 |
| <b>Additional reliability data</b>  |                             |          |     |    |     |     |
| <b>Mechanical impact test, degree of precision to IEC 68-2-6-1987; Part 2-27;</b> | n<br>ms<br>m/s <sup>2</sup> | 1000     |     |    |     |     |
| Number  |                             | 3        |     |    |     |     |
| Duration  |                             | 500      |     |    |     |     |
| <b>Vibration stress test, degree of precision to IEC 68-2-6-1982; Part 2-6;</b>   | Hz<br>h<br>m/s <sup>2</sup> | 5 ... 65 |     |    |     |     |
| Frequency range   |                             | 1.5      |     |    |     |     |
| Duration  |                             | 50       |     |    |     |     |
| <b>Acceleration</b>   |                             | 50       |     |    |     |     |
| <b>Protection class, according to EN 60 529</b>                                   |                             | IP50     |     |    |     |     |
| <b>Weight, approx.</b>  | kg                          | 0.5      | 0.6 |    |     |     |

## 9 Dimensions

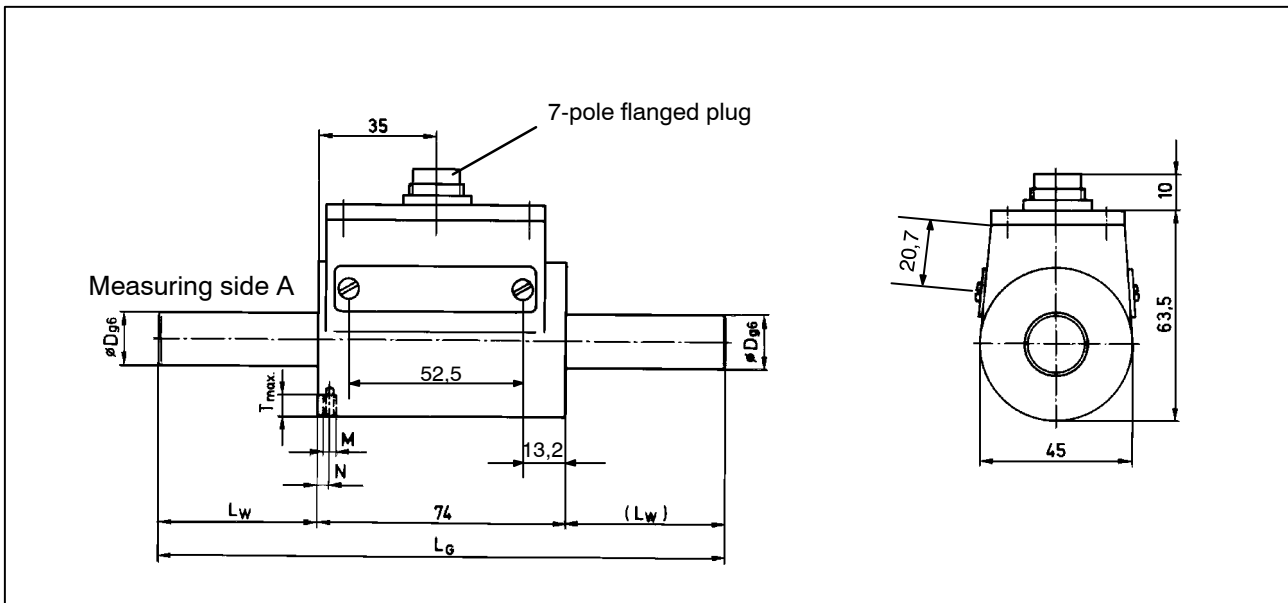

| Type      | $L_G$ | $L_W$ | $D_{g6}$ | M  | N   | $T_{max}$ |
|-----------|-------|-------|----------|----|-----|-----------|
| T5/10N·m  | 132   | 29    | 14       | M4 | 3.5 | 6         |
| T5/20N·m  | 132   | 29    | 16       | M4 | 3.5 | 6         |
| T5/50N·m  | 158   | 42    | 16       | M4 | 3.5 | 6         |
| T5/100N·m | 158   | 42    | 20       | –  | –   | –         |
| T5/200N·m | 168   | 47    | 20       | –  | –   | –         |



Modifications reserved.  
All details describe our products in general form only. They are not to be understood as express warranty and do not constitute any liability whatsoever.

**Hottinger Baldwin Messtechnik GmbH**

Postfach 10 01 51, D-64201 Darmstadt  
Im Tiefen See 45, D-64293 Darmstadt  
Tel.: +49/61 51/ 8 03-0; Fax: +49/61 51/ 8039100  
E-mail: [support@hbm.com](mailto:support@hbm.com) [www.hbm.com](http://www.hbm.com)



measurement with confidence