

Mounting Instructions

Reference
torque measuring-disc

TB1A

Contents	Page
Safety instructions	4
1 Scope of supply	7
2 Application	7
3 Structure and mode of operation	8
3.1 Mechanical structure	8
4 Mounting	8
4.1 General installation notes	8
4.2 Mounting position	11
4.3 Conditions on site	11
4.4 Mechanical installation	11
4.5 Loading capacity	17
5 Electrical connection	18
5.1 Notes for cabling	19
5.2 Four-wire technique	20
6 Maintenance	20
7 Accessories	20
8 Specifications	21
9 Dimensions	24
10 Copy of Declaration of Conformity	25

Safety instructions

Use in accordance with the regulations

Reference torque measuring-discs TB1A are used exclusively for torque measurement tasks and control and adjustment tasks directly connected thereto. Use for any additional purpose shall be deemed to be **not** in accordance with the regulations.

In the interests of safety, the transducer should only be operated as described in the Mounting Instructions. It is also essential to observe the appropriate legal and safety regulations for the application concerned during use. The same applies to the use of accessories.

The transducer is not a safety element within the meaning of its use as intended. Proper and safe operation of this transducer requires proper transportation, correct storage, assembly and mounting and careful operation.

General dangers of failing to follow the safety instructions

The transducer corresponds to the state of the art and is fail-safe. The transducer can give rise to remaining dangers if it is inappropriately installed and operated by untrained personnel.

Everyone involved with the installation, commissioning, maintenance or repair of the transducer must have read and understood the Operating Manual and in particular the technical safety instructions.

Remaining dangers

The scope of supply and performance of the transducer covers only a small area of torque measurement technique. In addition, equipment planners, installers and operators should plan, implement and respond to the safety engineering considerations of torque measurement technique in such a way as to minimize remaining dangers. Prevailing regulations must be complied with at all times. Reference must be made to remaining dangers connected with torque measurement technology.

In this Mounting Instruction remaining dangers are pointed out using the following symbols:



Symbol:

WARNING

Meaning:

Potentially dangerous situation

Warns of a **potentially** dangerous situation in which failure to comply with safety requirements **can** result in death or serious physical injury.



Symbol:

CAUTION

Meaning:

Potentially dangerous situation

Warns of a **potentially** dangerous situation in which failure to comply with safety requirements **could** result in damage to property or some form of physical injury.

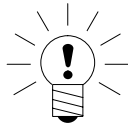

Symbol:

NOTE

Means that important information about the product or its handling is being given.



Symbol:

Meaning: **CE mark**

The CE mark enables the manufacturer to guarantee that the product complies with the requirements of the relevant EC directives (see Declaration of conformity at the end of this document).

Conversions and modifications

The transducer must not be modified from the design or safety engineering point of view except with our express agreement. Any modification shall exclude all liability on our part for any damage resulting therefrom.

Qualified personnel

The transducer must only to be installed and used by qualified personnel, strictly in accordance with the specifications and with safety requirements and regulations. It is also essential to observe the appropriate legal and safety regulations for the application concerned during use. The same applies to the use of accessories.

Qualified personnel means persons entrusted with the installation, fitting, commissioning and operation of the product who possess the appropriate qualifications for their function.

1 Scope of supply

The scope of supply includes the following:

- 1 Reference torque measuring-disc
- 1 Mounting Instructions
- 1 Test record

2 Application

Transducers measure static and dynamic torques in non-turning mode. The nominal torques fall within the range 100 N·m to 10 kN·m.

Transfer torque transducer

The main applications are torque transfer, for example, when calibrating reference transducers in test and calibration machines and comparisons of the reference normals of various calibration laboratories.

In the case of transfer transducers, a high degree of comparability is important, as when relaying torque, this provides a gage for various observers, test conditions, laboratories and the installation and time situation. So for relay, the same installation conditions should be created as for calibration in the reference normal, or relevant adapters (for recommendations, see Page 16f) should be included in the calibration.

Reference torque transducer

Reference torque transducers are mounted in a calibration device and then the entire calibration machine is qualified or certified by means of transfer torque transducers, for example. The precise sensitivity of the transducer is thus less important.

General torque measurements in non-turning mode

Because of the high mechanical loading capacity, the permissible vibration bandwidth of 160 % (10 kN·m = 120 %) of nominal torque and the compact design, the transducers are also eminently suitable for use in testing machines for component testing (rotary alternating stress) or as reaction torque transducers, for example in agitators with direct drive motor or gearbox connection.

3 Structure and mode of operation

3.1 Mechanical structure

The reference torque measuring-disc comprises a measuring body applied with strain gages and a mounting flange screw fitted to it.

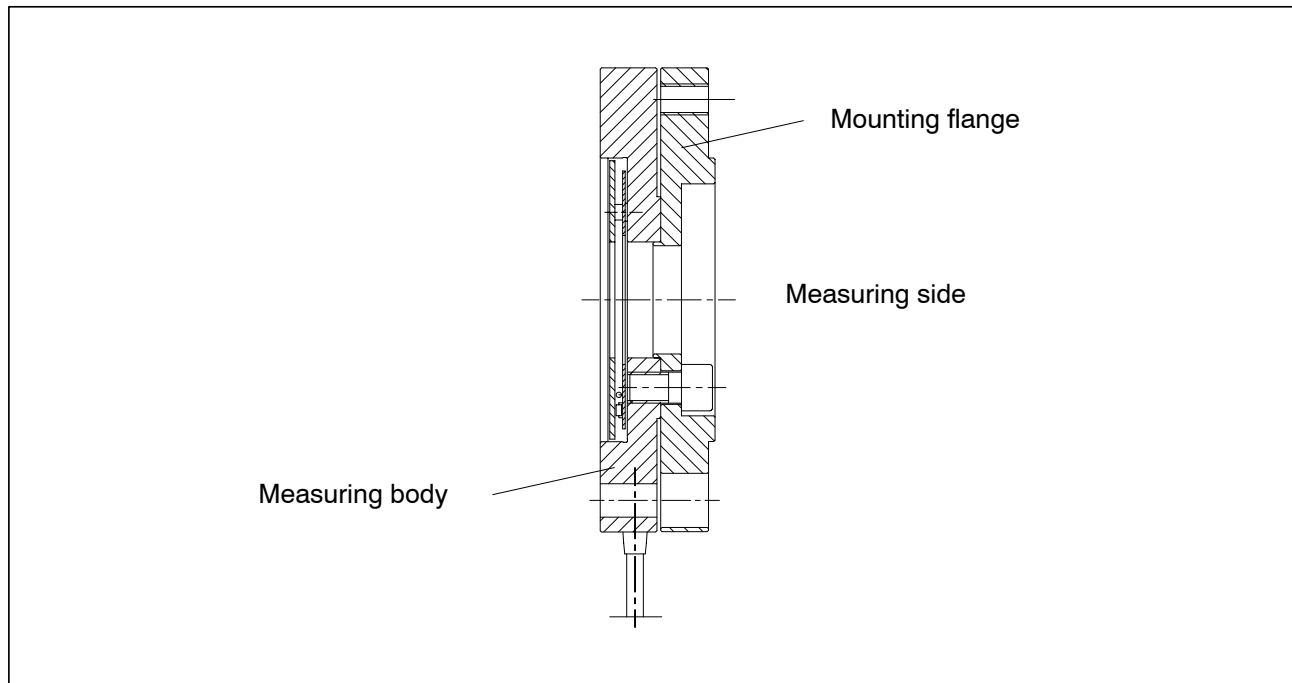

Fig.3.1: Mechanical structure

4 Mounting

4.1 General installation notes

When the torque measuring-disc is fitted in test benches, the test bench components (frame, couplings, mounting flanges, screw fittings, etc.), affect the deflection performance in the shaft run and thus the measuring characteristics (zero point, sensitivity, reproducibility). The causes for this can include:

- Additional parasitic loadings such as radial forces, axial forces or bending moments
- Asymmetrical torque introduction in the transducers

- Different stiffness conditions in the shaft run to those of transducer calibration

These test bench reactions on the reference transducer are calibrated in by adaptable lever-ground systems, for example.

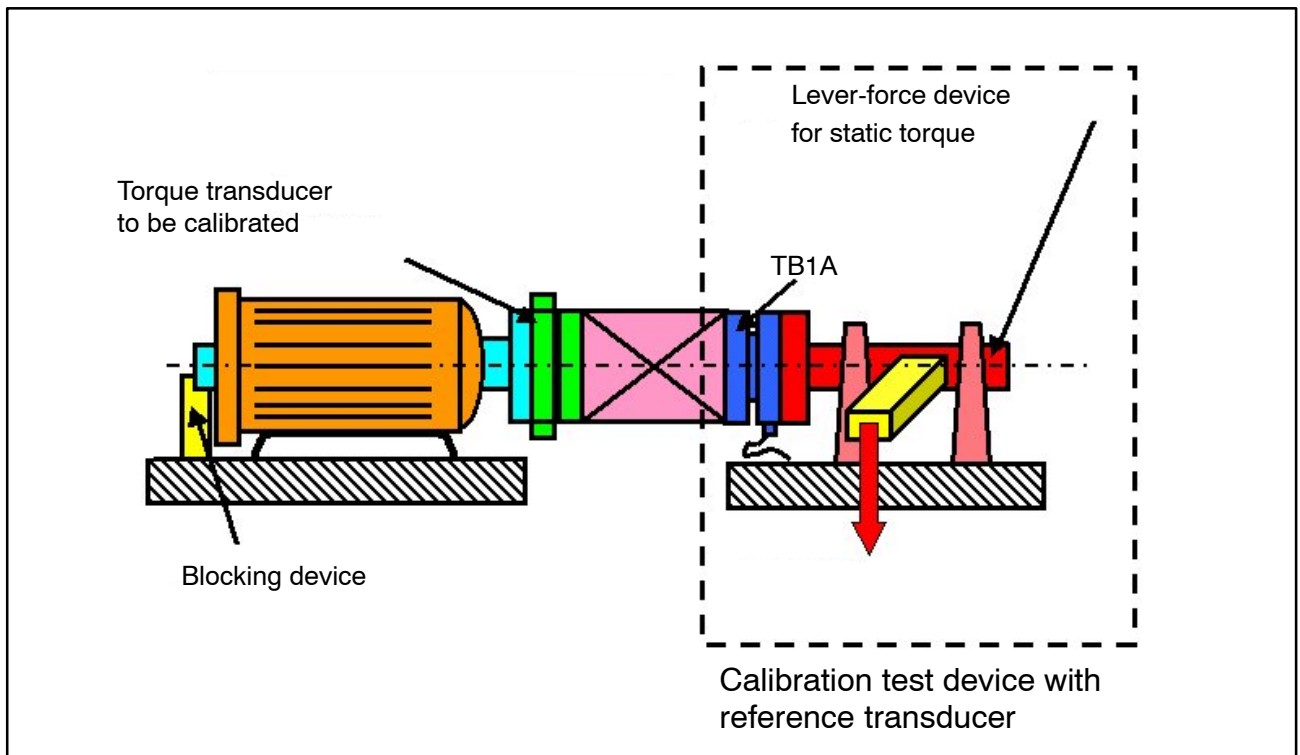

Fig.4.1: Typical installation in a calibration test device

Parasitic loadings

Parasitic loadings are caused by deformations in the shaft run. They result in an additive effect on the zero signal of the torque measuring-disc (see Specifications). If they occur during a torque loading, they cause an apparent change in sensitivity.

Countermeasures:

1. Optimum alignment of the shaft run (note alignment data in the Specifications!).
As long as you do not exceed the permissible limits for bending moments, transverse force and longitudinal force, no special couplings or other measures are required to install the reference torque measuring-disc (effect on the measurement result approx. 1 % of nominal torque).

2. If you cannot achieve the requisite alignment accuracy, use non-interacting couplings.
3. Keep the weight of the shaft sections acting on the torque measuring-disc as low as possible.

Depending on the design of the test bench, decoupling measures with torsionally stiff but pliable torsion bars may be necessary.

Different stiffness conditions

If the stiffness conditions in the shaft run (near the torque measuring-disc) differ to the conditions during calibration in the HBM normal measuring device, this can change the torque introduction to the torque measuring-disc.

Countermeasures:

1. Keep strictly to the prescribed fastening bolt tightening torques.
2. Use high-strength or hardened adaptation components, especially close to the torque introductions and torque outlets of the torque measuring-disc.

Asymmetrical torque distributions

Asymmetrical (axially uneven) torque distribution in the shaft run can lead to deflections, that then cause parasitic loadings.

Countermeasures:

1. Use all the available screw connections for the mounting.
2. Keep strictly to the prescribed fastening bolt tightening torques.
3. Avoid making unnecessary bore holes in the adaptation flanges.
4. Use flange surfaces that are clean, flat and as polished as possible.
5. Avoid having torque introductions and outlets right on the outside diameter of the measuring disc.
6. Use adaptation flanges with sufficiently large clearance bores to stop the screws locking up.

4.2 Mounting position

The reference torque measuring-disc can be installed in any position. With clockwise momentum, there is a positive output signal in conjunction with the HBM measuring amplifiers.

4.3 Conditions on site

The TB1A reference torque measuring-discs are protected to IP54 according to EN 60529. The measuring-discs must be protected from dirt, dust, oil, solvents and humidity.

During operation, the prevailing safety regulations for the security of personnel must be observed.

4.4 Mechanical installation



NOTE

Handle the reference torque measuring-disc carefully. The transducer might suffer permanent damage from mechanical shock (dropping), chemical effects (e.g. acids, solvents) or thermal effects (hot air, steam).



CAUTION

You must not loosen the screwed joints of the measuring body and mounting flange and the slotted screws of the identification plate marked at the factory by safety paint.

When installing the reference torque measuring-disc as a comparison standard in calibration test benches, the torque to be measured is introduced from the measuring side (see Fig.4.2).

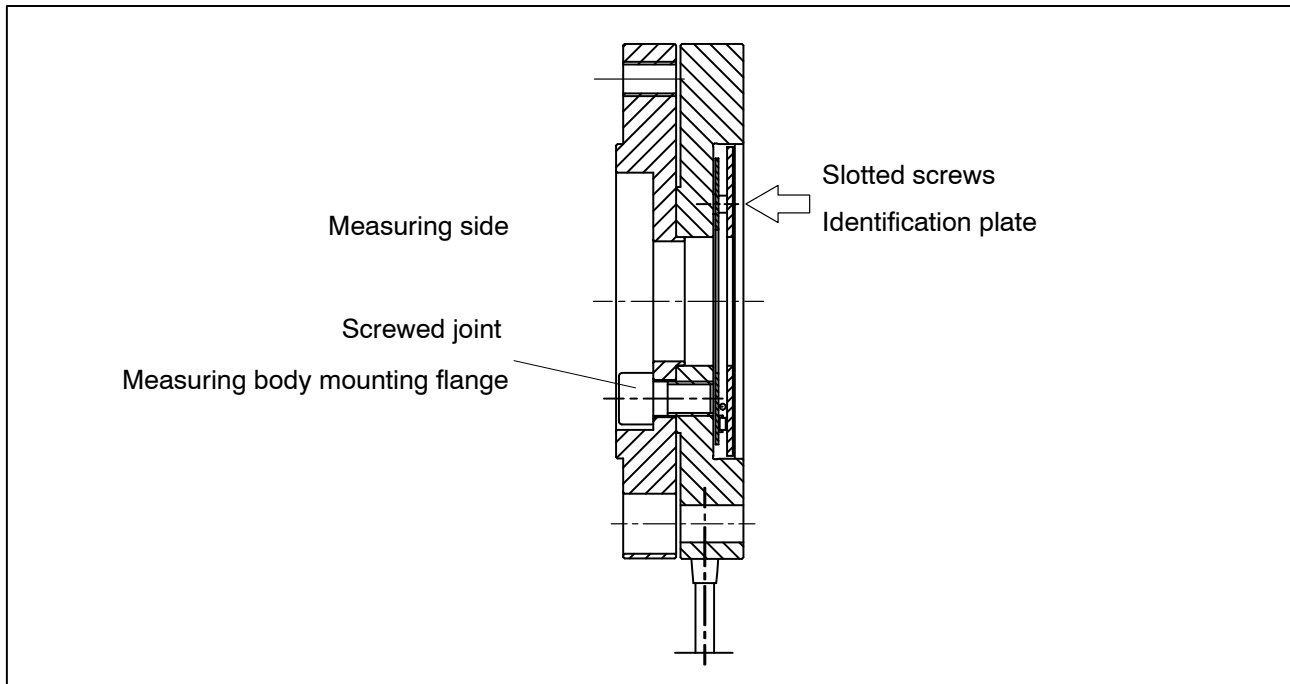

Fig.4.2: Screwed joints painted at the factory

Assembly sequence:

1. Use flange surfaces (minimum material strength $> 900 \text{ N/mm}^2$; hardness $> 30 \text{ HRC}$) that are clean, flat (run-out tolerance 0.01 mm) and as polished as possible ($R_t < 0.8$).
2. Prior to installation, clean the plane flange surfaces of the torque-measuring disc and of the counter flanges. For safe torque transfer, the surfaces must be clean and free from grease. Use a piece of cloth or paper soaked with a solvent. Make sure that no solvent drips into the gaging flange's interior.
3. Use eight **DIN EN ISO 4762; black/oiled/ $\mu_{\text{tot}}=0,125$ hexagon-socket screws, property class 10.9 (measuring range $10 \text{ kN}\cdot\text{m}$: 12.9)**, of the appropriate length (depending on the connection geometry, see Table 4.1) to screw-fasten the measuring body.

We recommend, particularly for $100 \text{ N}\cdot\text{m}$ and $200 \text{ N}\cdot\text{m}$ situations, fillister-head screws DINEN ISO 4762 or similar, blackened, smooth-headed, permitted size and shape variance in accordance with DIN ISO 4759, Part 1, product class A.

**WARNING**

The screw heads (Z), see Fig.4.3, must not sit on the mounting flange. With alternating loads: glue all the connection screws into the counter thread with a screw locking device (medium) to exclude a pretension loss due to screw slackening.

4. With a cut thread, the adapter material should have a yield point of at least 900 N/mm^2 .

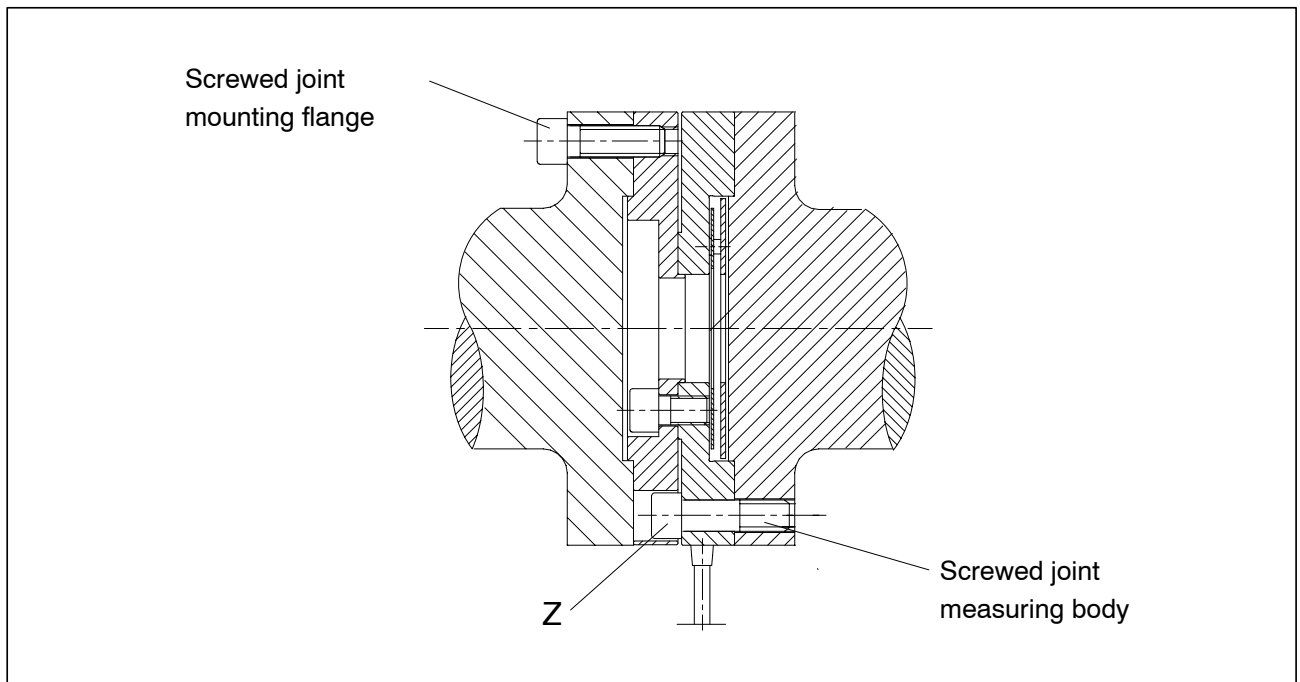

Fig.4.3: Screwed joint of the measuring body

5. Before finally fastening the screws, turn the reference torque measuring-disc on the centering until all screw heads are located about centrically in the connection element's clearance bores. The screw heads may in no case be in contact with the sides of the mounting-flange clearance bores.
6. Fasten all screws with the specified tightening torque (Table 4.1).
7. For further installation of the shafting, there are eight threaded bores on the mounting flange. Also use screws of property class 10.9 and fasten with the tightening torque specified in Table 4.1.



CAUTION

It is essential to keep to the maximum thread reach in the mounting flange (as per Table 4.1) ! Otherwise, considerable measurement errors might occur or the transducer might suffer damage.

Nominal torque (N·m)	Fastening bolts (Z) measuring body	Fastening bolts property class	Maximum thread reach (Y) of the screws in the mounting flange (mm)	Prescribed tightening torque (N·m)
100	M6	10.9	7.5	14
200	mM8		11	34
500	M12		18	115
1k	M12		18	115
2k	M14		18	185
5k	M18		33.5	400
10k	M18	12.9 ¹⁾	33.5	470

Table 4.1: Fastening bolts

¹⁾If screws of Class 12.9 are not available, Class 10.9 screws (400 N·m tightening torque) can be used. The permissible limiting torque is reduced then to 120 % referred to M_N .

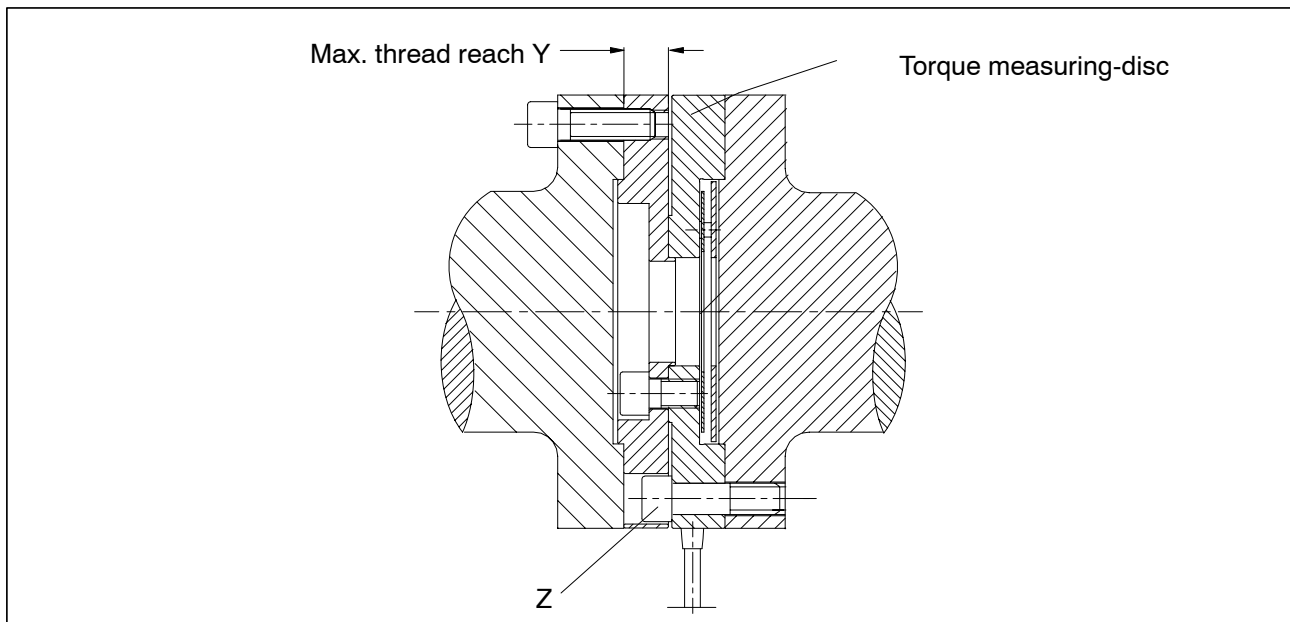

Fig.4.4: Installation example

Installing as a transfer transducer

Transfer transducers must be as insensitive as possible to all installation influences. This can be achieved in the design, for example, by specially developed adaptation flanges.

For optimum transfer of sensitivity, observe the following points in addition to the recommendations for reference transducers already mentioned:

- Introduce the torque into the torque measuring-disc from the inside (D_I) to the outside (D_A), at a ratio of $\frac{D_I}{D_A} \leq 0.6$.
- The width of the adaptation flange (B) on the reaction side should be 1.5 – 2 times the diameter of the flange screw.

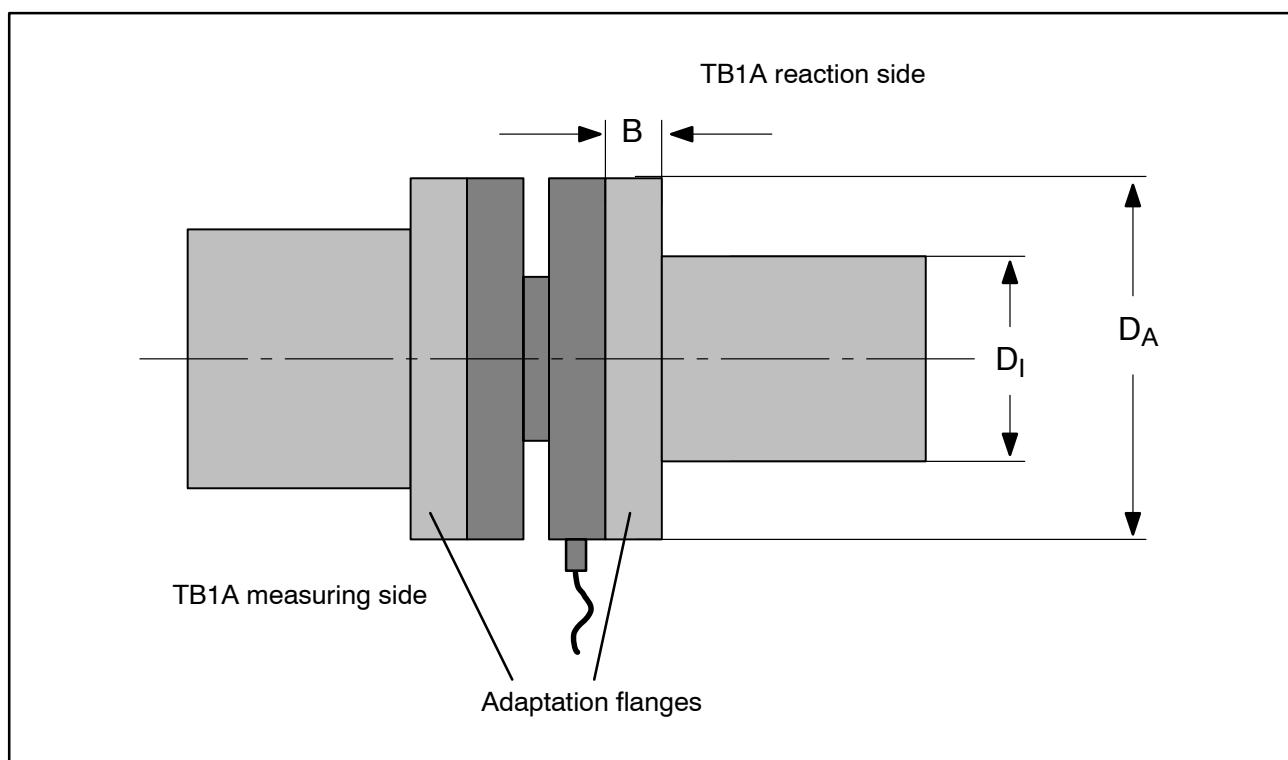

Fig.4.5: Adaptation flange transfer transducer

As an alternative to shaft stubs, you can also use an additional adaptation flange that is mounted on the sensor side and is included in the measurement (see Fig.4.6).

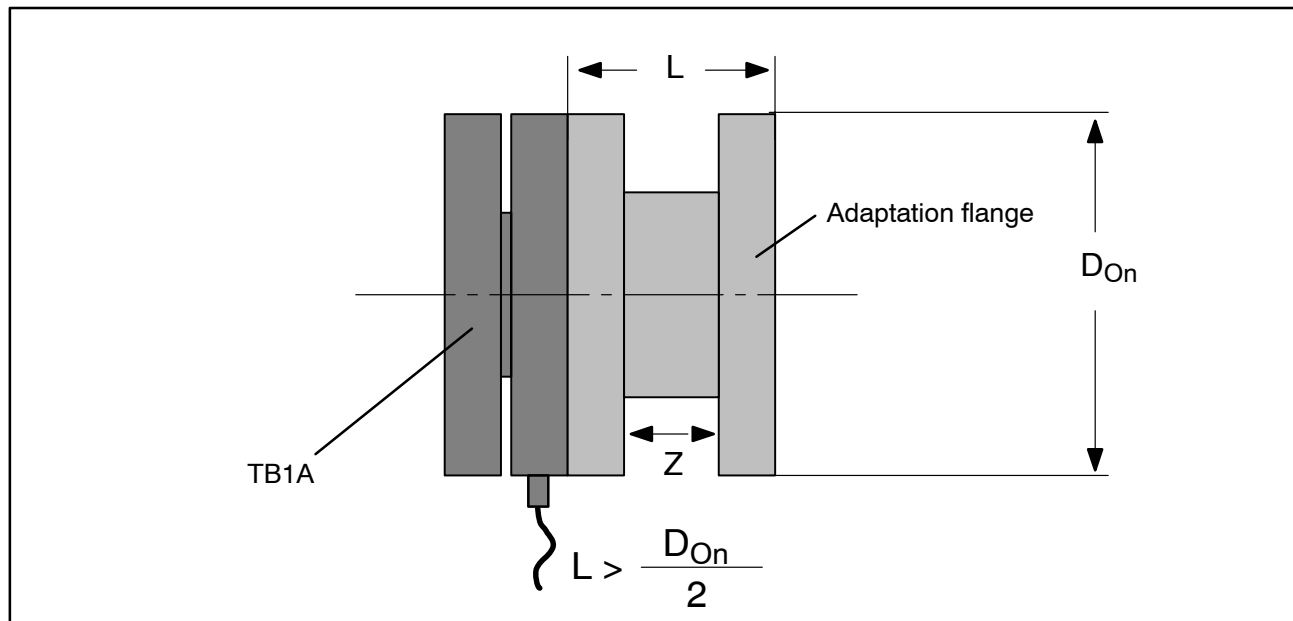

Fig.4.6: Additional adaptation flange for transfer transducers

To make it easy to install the gaging flange with the adaptation flange, we recommend the following flange design:

- Provide clearance bores on the reverse of the flange to correspond to the bore pattern of the TB1A. The relative position of the clearance bores should correspond to the relative position of the tapped holes of the TB1A.
- The dimensions of flange clearance Z must be such that the connection screws can be put through and tightened with a torque wrench.

4.5 Loading capacity

The torque measuring-discs can be used to measure static and dynamic torques.

Please note the following when measuring dynamic torque:

- The calibration made for static torques is also valid for dynamic torque measurements.
- The natural frequency f_0 for the mechanical measuring system depends on the moments of inertia J_1 and J_2 of the connected rotating masses and the TB1A's torsional stiffness.

Use the below equation to determine the natural frequency f_0 for the mechanical measuring system:

$$f_0 = \frac{1}{2\pi} \cdot \sqrt{c_T \cdot \left(\frac{1}{J_1} + \frac{1}{J_2} \right)}$$

f_0	=	Natural frequency in Hz
J_1, J_2	=	Mass moment of inertia in kgm^2
c_T	=	Torsional stiffness in $\text{N}\cdot\text{m}/\text{rad}$

- The maximum permissible amplitude of vibration (peak-to-peak) may be 160 % (at nominal torque $10 \text{ kN}\cdot\text{m}=120 \%$) of the TB1A's nominal torque, even with alternating load. In all cases the vibration bandwidth must lie within the loading range defined by $-M_N$ and $+M_N$.

Caution: Even in a resonance situation, you must keep to the mechanical limits. Torsion spring rigidity and moment of inertia for estimating the the natural frequency, can be found in Chapter 8.

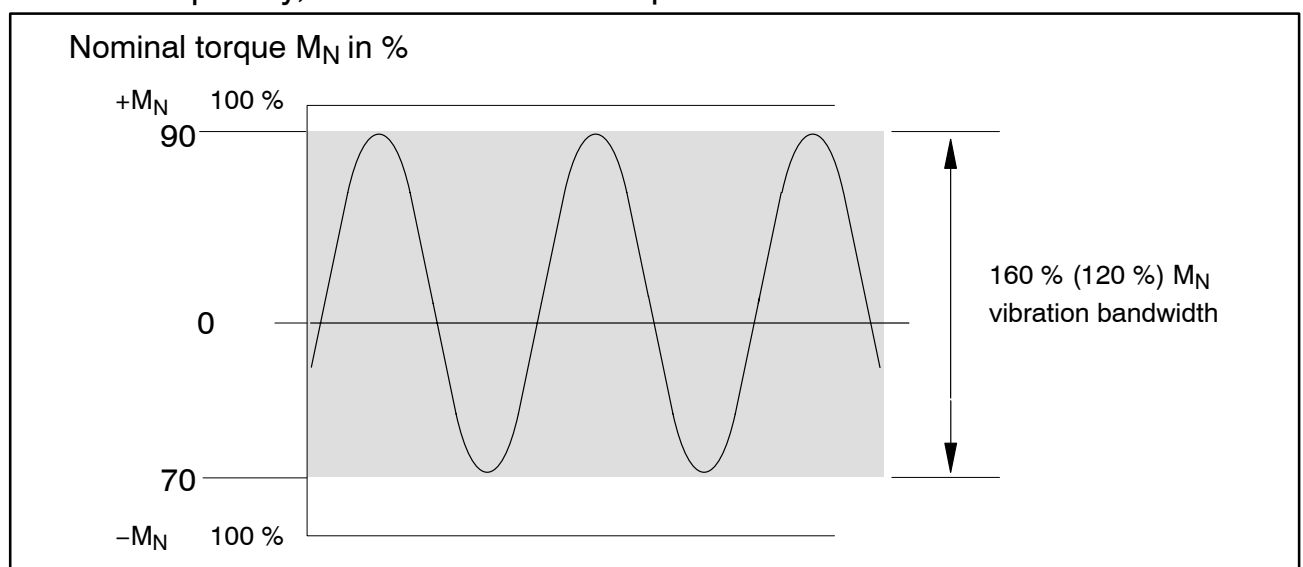

Fig.4.7: Permissible dynamic loading

5 Electrical connection

Reference torque measuring-discs are equipped with a fixed 6-wire connection cable (six wire circuit) with free ends. A connector assembly is possible on request (see Chapter 7.)

Extension cables should be shielded and low-capacitance. HBM provides cables 1-KAB0304A-10 (ready-made) and KAB8/00-2/2/2 (by the meter, can also be supplied with fitted appliance connector) especially for this.

The pin assignment for HBM measuring amplifiers can be found in the following table:

Connection	Wire colour	Connection to a measuring amplifier with	
		15-pin Sub-D connector	7-pin connector
Measurement signal (+U _A)	White	8	A
Excitation voltage (-U _B)	Black	5	B
Excitation voltage (+U _B)	Blue	6	C
Measurement signal (-U _A)	Red	15	D
Sensor circuit (-)	Gray	12	G
Sensor circuit (+)	Green	13	F
Shielding connected to enclosure ground	Yellow	1	E

Table 5.1: Pin assignment

The measuring amplifier pin assignments with soldered or clamped connection can be found in the documentation of the particular amplifier.

5.1 Notes for cabling

Electrical and magnetic fields often cause interference voltages to be injected into the measuring circuit. This interference starts primarily from power lines lying parallel to the measuring leads, but can also start from any contactors or electric motors in the vicinity. In addition, interference voltages can be injected galvanically, especially if the measurement chain is grounded at several points.

Please take note of the following:

- Use only shielded and low-capacitance measurement cables from HBM.
- Do not install measurement cables parallel to power lines or control circuits. If this is not possible (e.g. in cable shafts), protect the measurement cable by armoured steel tubing, for example and keep it a minimum of 50 cm away from other cables. Power lines or control circuits should be twisted together (15 twists per meter).
- The stray fields of transformers, motors and contactors should be avoided.
- Do not ground transducers, amplifiers and indicating instruments repeatedly. All the devices of the measurement chain should be connected to the same grounded conductor.
- The shield of the connection cable is connected to the transducer housing.
- Connection diagram, grounding concept (Greenline).

Grounding concept (Greenline).

The cable shielding is connected in accordance with the Greenline concept. This encloses the measurement system in a Faraday cage. Any electromagnetic interference active here does not affect the measurement signal. Special electronic coding methods are used to protect the transmission path from electromagnetic interferences.

In the case of interferences due to potential differences (compensating currents), operating-voltage zero and housing ground must be disconnected on the amplifier and a potential equalization line between housing and amplifier housing must be established (highly flexible stranded wire, 10 mm² wire cross-section).

5.2 Four-wire technique

If the reference torque measuring-disc has to be operated with a measuring amplifier using the four-wire technique, then the **black** wire is connected to the **gray** wire and the **green** wire is connected to the **blue** wire. The sensitivity of the transducer changes by approx. 0.022 %. The sensitivity temperature coefficient variation (TK_C) is negligible. Changes in cable lengths cause a sensitivity variation. The influences of temperature on the cable are not corrected. However, measurement accuracy is adequate for many measurement requirements, even in the case of the four-wire technique.

6 Maintenance

The TB1A reference torque measuring-discs are maintenance free.

7 Accessories

to be ordered separately:

- Connector assembly
- Ready-made extension cable 1–Kab0304A–10.
- Extension cable Kab8/00–2/2/2, lengths from 10 m.

8 Specifications

Type	TB1A							
Accuracy class	0,05							
Torque measuring system								
Nominal (rated) torque M_N	N·m	100	200	500	1k	2k	5k	10k
for reference only	ft-lb	75	150	375	750	1,500	3,750	7,500
Nominal (rated) sensitivity (nominal (rated) signal range between torque = zero and nominal (rated) torque)	mV/V	1.5						
Sensitivity tolerance (deviation of the actual output value from the nominal (rated) signal range at M_N)	%	< ±0.1						
Effect of temperature per 10 K in nominal (rated) temperature range								
of output signal related to the actual value of signal span	%	< ±0,1						
on the zero signal , related to the nominal (rated) sensitivity	%	< ±0.05						
Linearity deviation including hysteresis , related to the nominal (rated) sensitivity	%	< ±0.03						
Rel. standard deviation of reproducibility according to DIN 1319, by reference to variation of the output signal	%	< ±0.01						
Input resistance for reference temperature	Ω	1750 ± 150						
Output resistance for reference temperature	Ω	1400 ± 30						
Reference excitation voltage	V	5						
Max. safe excitation voltage	V	20						
Operating range of the excitation voltage	V	2.5...12						
Reference temperature	°C	+23						
Nominal (rated) temperature range	°C	+10...+60						
Operating temperature range	°C	-10...+60						
Storage temperature range	°C	-20...+70						

Nominal (rated) torque M_N	N·m	100	200	500	1k	2k	5k	10k
for reference only	ft-lb	75	150	375	750	1,500	3,750	7,500
Load limit ¹⁾								
limit torque, related to M_N	%	200						
Breaking torque, related to M_N	%	> 400						
Longitudinal limit force	kN	2	4	7	7	12	22	31
Lateral limit force	kN	1	3	6	8	15	30	40
Bending limit moment	N·m	70	140	500	500	1000	2500	4000
Vibration bandwidth according to DIN 50 100 (peak-to-peak) ²⁾	kN·m	0.16	0.32	0.8	1.6	3.2	8.0	12.0
Mechanical values								
Torsional stiffness	kN·m/ rad	160	430	1000	1800	3300	9900	15000
Torsion angle at M_N	Deg.	0.036	0.027	0.028	0.032	0.034	0.029	0.038
Maximum excursion at longitudinal force limit	mm	< 0.03						
Additional max. concentric error at lateral force limit	mm	< 0.01		< 0.02		< 0.03		
Additional in-plane deviation at bending moment limit	mm	< 0.2						
Mass moment of inertia around the rotary axis $\times 10^{-3}$	kg·m ²	1.3	3.4	13.2	13.2	29.6	110	120
Proportional mass moment of inertia (sensor side)	%	51	44	39	39	38	31	33
Supplementary reliability data								
Mechanical shock, degree of precision to DIN IEC 68; part 2-27; IEC 68-2-27-1987								
Number	n	1000						
Duration	ms	3						
Acceleration (half-sine)	m/s ²	650						
Vibration stress test, degree of precision to DIN IEC 68, part 2-6: IEC 68-2-6-1982								
Frequency range	Hz	5...65						
Duration	h	1.5						
Acceleration (amplitude)	m/s ²	50						
Protection class according to EN 60529		IP 54						
Weight, approx. (without cable)	kg	0.9	1.8	3.5	3.5	5.8	14	15.2

¹⁾ Each type of irregular stress (bending moment, lateral or longitudinal force, exceeding nominal (rated) torque) can only be permitted up to its specified static loading limit provided none of the others can occur at the same time. If this condition is not met, the limit values must be reduced. If 30% of the bending moment limit and lateral force limit occur at the same time, only 40% of the longitudinal force limit is permissible and nominal (rated) torque must not be exceeded. The permissible bending moments, longitudinal forces and lateral forces can affect the measurement result by approx. 1% of nominal (rated) torque.

²⁾ The nominal (rated) torque must not be exceeded.

Supplementary data on classification by means of DKD (German Calibration Service) measurement according to DIN 51309

Type		TB1A						
Class		0.1 (typically 0.05)						
Nominal (rated) torque M_N	N·m	100	200	500	1k	2k	5k	10k
for reference only	ft-lb	75	150	375	750	1,500	3,750	7,500
Relative zero error f_0 (zero signal return), related to full scale	%	< ± 0.025 (typically < ± 0.012)						
Relative range ($0.2M_N$ to M_N) , related to actual value								
for unchanged mounting position b'	%	< 0.025 (typically < 0.01)						
for various mounting positions b	%	< 0.05 (typically < 0.02)						
Relative reversibility error ($0.2M_N$ to M_N) h , related to actual value	%	< 0.12 (typically < 0.06)						

9 Dimensions

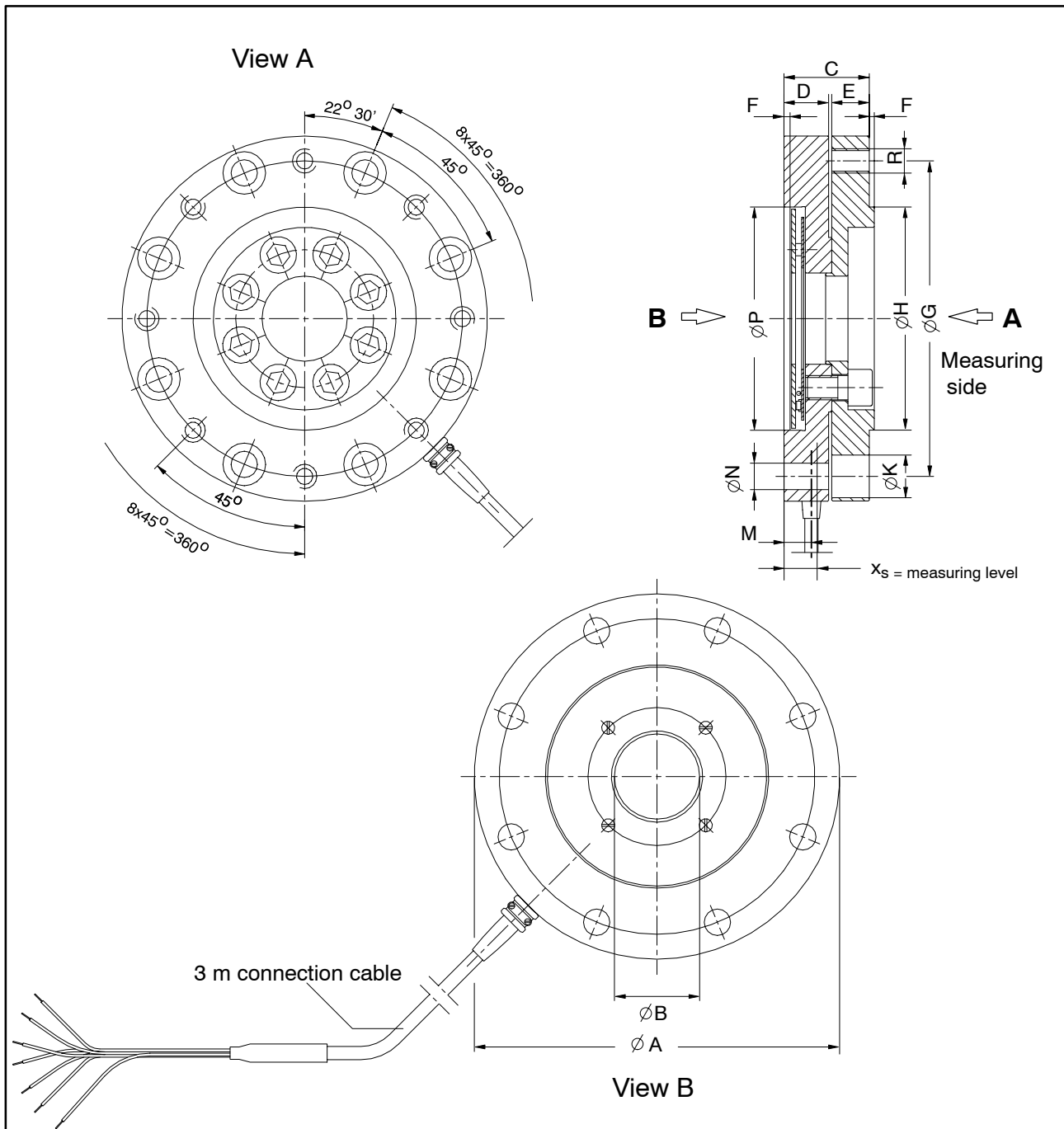

Nominal (rated) torque	$\varnothing A$	$\varnothing B_{\pm 0.1}$	C	D	E	$F_{+0.2}$	$\varnothing G_{\pm 0.1}$	$\varnothing H_{g6}$	$\varnothing K$	M	$\varnothing N$	$\varnothing PH7$	R	x_s
100 N·m	100	40.2	25	15.5	7.5	2,5	87	75	11	7.8	6.4	75	8xM6	13
200 N·m	121	40.2	30.5	17.5	11	2,5	105	90	14	8.8	8.4	90	8xM8	14
500 N·m	156	41	40,5	20.5	18	2,5	133	110	20	9	13	110	8xM12	15.5
1 kN·m	156	41	40.5	20.5	18	2,5	133	110	20	9	13	110	8xM12	15.5
2 kN·m	191	69	42.5	22.5	18	2,5	165	140	24	9	15	140	8xM14	16.5
5 kN·m	238	79	64	28.5	33.5	2,5	206	174	30	9	19	174	8xM18	19.5
10 kN·m	238	79	69	33.5	33.5	2,5	206	174	30	9	19	174	8xM18	22.5

10 Copy of Declaration of Conformity



**HOTTINGER
BALDWIN
MESSTECHNIK**

HBM MESS- UND SYSTEMTECHNIK GMBH
Im Tiefen See 45 - D-64293 Darmstadt
Tel. ++49/6151/803-0, Fax. ++49/6151/894896

Konformitätserklärung

Declaration of Conformity

Déclaration de Conformité

Document: 122/11.1998

Wir,

We,

Nous,

HBM Mess- und Systemtechnik GmbH, Darmstadt

erklären in alleiniger Verantwortung,
daß das Produkt

declare under our sole
responsibility that the product

Déclarons sous notre seule
responsabilité que le produit

Referenz-Drehmomentmeßscheibe TB1A

auf das sich diese Erklärung
bezieht, mit der/den folgenden
Norm(en) oder normativen
Dokument(en) übereinstimmt (siehe
Seite 2) gemäß den Bestimmungen
der Richtlinie(n)

to which this declaration relates is
in conformity with the following
standard(s) or other normative
document(s) (see page 2)
following the provisions of
Directive(s)

Auquel se réfère cette déclaration
est conforme à la (aux) norme(s) ou
autre(s) document(s) normatif(s)
(voir page 2) conformément aux
dispositions de(s) Directive(s)

89/336/EWG - Richtlinie des Rates vom 3. Mai 1989 zur Angleichung der Rechtsvorschriften der Mitgliedsstaaten über die elektromagnetische Verträglichkeit, geändert durch 91/263/EWG, 92/31/EWG und 93/68/EWG

Die Absicherung aller produkt-spezifischen Qualitätsmerkmale erfolgt auf Basis eines von der DQS (Deutsche Gesellschaft zur Zertifizierung von Qualitätsmanagementsystemen) seit 1986 zertifizierten Qualitätsmanagementsystems nach DIN ISO 9001 (Reg.Nr. DQS-10001).

Die Überprüfung der sicherheitsrelevanten Merkmale (Elektromagnetische Verträglichkeit, Sicherheit elektrischer Betriebsmittel) führt ein von der DATech erstmals 1991 akkreditiertes Prüflaboratorium (Reg.Nr. DAT-P-006 und DAT-P-012) unabhängig im Hause HBM durch.

All product-related features are secured by a quality system in accordance with DIN ISO 9001, certified by DQS (Deutsche Gesellschaft zur Zertifizierung von Qualitätsmanagementsystemen) since 1986 (Reg. No. DQS-10001). The safety-relevant features (electromagnetic compatibility, safety of electrical apparatus) are verified at HBM by an independent testing laboratory which has been accredited by DATech in 1991 for the first time (Reg. Nos. DAT-P-006 and DAT-P-012).

Chez HBM, la détermination de tous les critères de qualité relatifs à un produit spécifique est faite sur la base d'un protocole DQS (Deutsche Gesellschaft zur Zertifizierung von Qualitätsmanagementsystemen) certifiant, depuis 1986, notre système d'assurance qualité selon DIN ISO 9001 (Reg.Nr. DQS-10001). De même, tous les critères de protection électrique et de compatibilité électromagnétique sont certifiés par un laboratoire d'essais indépendant et accrédité depuis 1991 (Reg.Nr. DAT-P-006 et DAT-P-012).

Darmstadt, 27.11.1998

Procl *Stads*

Document: 122/11.1998

Diese Erklärung bescheinigt die Übereinstimmung mit den genannten Richtlinien, beinhaltet jedoch keine Zusicherung von Eigenschaften.

Die Sicherheitshinweise der mitgelieferten Produktdokumentation sind zu beachten.

Folgende Normen werden zum Nachweis der Übereinstimmung mit den Vorschriften der Richtlinie(n) eingehalten:

EN 50082-2 : 1995

Elektromagnetische Verträglichkeit (EMV); Fachgrundnorm Störfestigkeit; Teil 2: Industriebereich; Deutsche Fassung

This declaration certifies conformity with the Directives listed above, but is no asseveration of characteristics.

Safety directions of the delivered product documentation have to be followed.

The following standards are fulfilled as proof of conformity with the provisions of the Directive(s):

Cette déclaration atteste la conformité avec les directives citées mais n'assure pas un certain caractère.

S.v.p. observez les indications de sécurité de la documentation du produit ajoutée.

Pour la démonstration de la conformité aux disposition de(s) Directive(s) le produit satisfait les normes:

Modifications reserved.
All details describe our products in general form only. They are not to be understood as express warranty and do not constitute any liability whatsoever.

Hottinger Baldwin Messtechnik GmbH

Postfach 10 01 51, D-64201 Darmstadt
Im Tiefen See 45, D-64293 Darmstadt
Tel.: +49/61 51/ 8 03-0; Fax: +49/61 51/ 8039100
E-mail: support@hbm.com www.hbm.com



measurement with confidence