

Torque/Screw torque Transducer

T4A, T4WA-S3

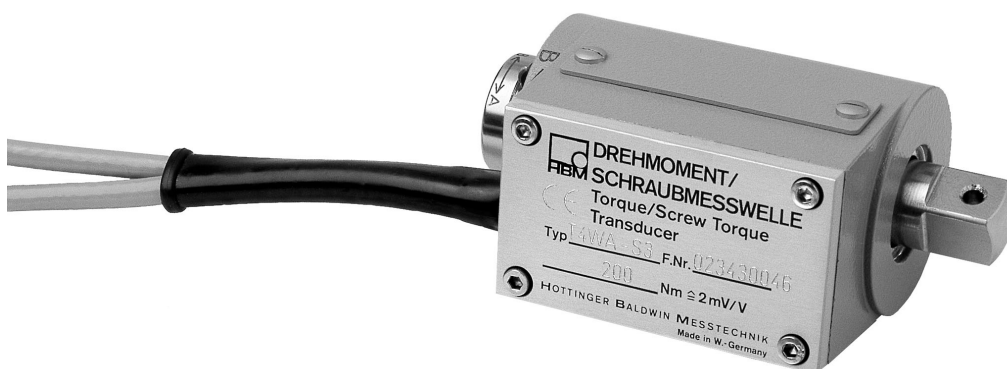

Contents	Page
Safety instructions	4
1 Application	7
2 Mounting	7
2.1 Mounting position	7
2.2 Fixing the enclosure in place	7
3 Electrical connection	8
3.1 General instructions	8
3.2 T4A pin assignment (torque)	8
3.3 T4WA-S3 pin assignment (torque)	9
3.4 T4WA-S3 pin assignment (speed/angle of rotation)	9
3.5 Cable extension	9
3.6 Shielding design	10
4 Loading capacity	11
4.1 Maximum rotation speed	11
4.2 Measuring dynamic torques	11
5 Displaying torque and direction of rotation	12
6 Maintenance	13
7 Dimensions	14
8 Specifications	15
9 Accessories	17
10 Copy of Declaration of Conformity	18

Safety instructions

Appropriate use

The T4A, T4WA-S3 torque/screw torque transducer may be used for torque measurement and directly related control and regulation tasks only. Any other use is **not** appropriate.

To ensure safe operation, the transducer may only be used according to the specifications given in this manual. When using the transducer, the legal and safety regulations for the respective application must also be observed. The same applies if accessories are used.

The transducer is not a safety device in accordance with the regulations for appropriate use. For correct and safe operation of this transducer it is essential to ensure technically correct transportation, storage, installation and fitting, and to operate all equipment with care.

General dangers in the case of non-observance of the safety instructions

The transducer complies with the state of the art and is fail safe. If the transducer is used and operated inappropriately by untrained personnel, residual dangers may arise.

Anyone responsible for installing, operating, maintaining or repairing this transducer must be sure to have read and understood the operating manual and in particular the notes on safety.

Residual dangers

The scope of performance and supply of this transducer covers only part of the torque measurement technology. In addition, those involved in planning, constructing and operating the safety engineering aspects of torque measurement technology must design, produce and take responsibility for such measures in order to minimise potential residual dangers. Prevailing regulations must be complied with at all times. There must be a clear reference to the residual dangers connected with measurement technology.

In this manual, the following symbols are used to refer to residual dangers:



Symbol: **DANGER**

Meaning: **Maximum danger level**

Warns of an **imminently** dangerous situation in which failure to comply with safety requirements **will result in** death or serious physical injury.



Symbol: **WARNING**

Meaning: **Potentially dangerous situation**

Warns of a **potentially** dangerous situation in which failure to comply with safety requirements **can result in** death or serious physical injury.



Symbol: **CAUTION**

Meaning: **Potentially dangerous situation**

Warns of a potentially dangerous situation in which failure to comply with safety requirements **could result in** damage to property or some form of physical injury.



Symbol: **NOTE**

Means that important information about the product or its handling is being given.



Symbol:

Meaning: CE mark

The CE mark enables the manufacturer to guarantee that the product complies with the requirements of the relevant EC guidelines (see Declaration of Conformity at the end of these Mounting Instructions).

Reconstruction and modifications

HBM's express consent is required for modifications affecting the transducer's construction and safety. HBM does not take responsibility for damage resulting from unauthorised modifications.

Qualified personnel

The transducer may be used by qualified personnel only; the technical data and the special safety regulations must be observed in all cases. When using the transducer, the legal and safety regulations for the respective application must also be observed. The same applies if accessories are used.

Qualified personnel means: personnel familiar with the installation, fitting, start-up and operation of the product, and trained according to their job.



WARNING

According to prevailing accident prevention regulations, after fitting the torque/screw torque transducer a cover must be fitted as follows:

- The cover must not be able to rotate.
- The cover shall protect against crushing or cutting and provide protection against parts that might come loose.
- The cover shall be installed at a safe distance from moving parts or shall prevent anyone putting their hand inside.
- The cover shall even be fitted if the moving parts are installed in areas to which persons do not usually have access.

The above regulations may only be disregarded if machine parts are already sufficiently protected owing to the design of the machine or because other precautions have been taken.

1 Application

T4A, T4WA-S3 torque/screw torque transducers measure constant and varying torques for any direction of rotation. T4WA-S3 transducers also measure the speed or angle of rotation.

The transducers can be used in conjunction with either manual or motorised screwdrivers (but not impact wrenches).

To enable wrenches and other bolting tools to be fitted, the transducer provides an internal square on the input side and an external square on the output side, both to DIN 3121.

2 Mounting

2.1 Mounting position

The torque/screw torque transducers can be fitted in any position. When installed horizontally, make sure that the identification plate is not pointing downward (to prevent the risk of a short circuit due to the accumulation of worn carbon on the printed circuit board).

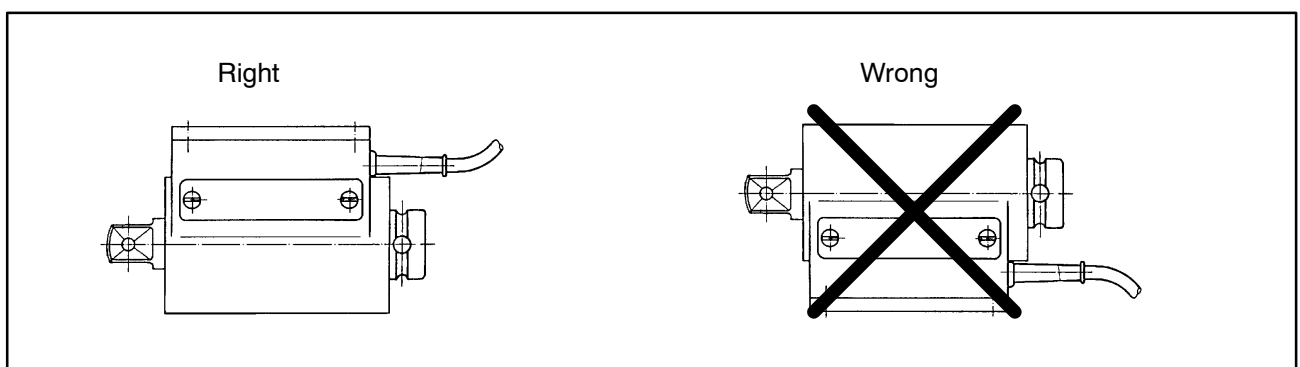

2.2 Fixing the enclosure in place

Bearing friction is very low in the case of screw torque transducers.

This means that the enclosure need only be secured against induced rotation.

For this purpose a size M4 (or M6) tapped hole is provided in the enclosure, on the output side, into which you may screw a suitable stop (such as a threaded bar).

The twist-proof fixing must have enough axial and radial play to ensure that no deformation arises between the enclosure and the rotor.

3 Electrical connection

T4A torque/ screw torque transducers are delivered complete with one 3 m–long, unterminated connection cable. The T4WA-S3 versions are delivered complete with two such cables.



NOTE

If you require a plug assembly, please be sure to specify the measuring amplifier type, and for system devices also specify the connection board you are using.

3.1 General instructions

We recommend to use shielded, low–capacitance cable from HBM for the electrical connection between torque transducer and measuring amplifier.

With cable extensions it is important to ensure that a good connection is provided, with minimum contact resistance and good insulation. All plug connections or cap nuts have to be tightened firmly.

Do not route measurement cables in parallel to power lines and control circuits. If this is not possible (for example in cable ducts), maintain a minimum distance of 50 cm and protect the cable with a steel tube.

Avoid transformers, motors, contactors, thyristor controllers and similar sources of stray fields.

3.2 T4A pin assignment (torque)

Wire colour	Function
White (wh)	Measurement signal torque (+)
Black (bk)	Excitation voltage (–)
Blue (bu)	Excitation voltage (+)
Red (rd)	Measurement signal torque (–)
Yellow (ye)	Cable shield to housing ground

3.3 T4WA-S3 pin assignment (torque)

Wire colour	Function
White (wh)	Measurement signal torque (+)
Black (bk)	Excitation voltage (-)
Blue (bu)	Excitation voltage (+)
Red (rd)	Measurement signal torque (-)
Grey (gy)	Sensor circuit (-)
Green (gn)	Sensor circuit (+)
Yellow (ye)	Cable shield to housing ground

3.4 T4WA-S3 pin assignment (speed/angle of rotation)

Wire colour	Function
Black (bk)	Zero operating voltage
Red (rd)	Supply voltage for speed measuring system
Green (gn)	Measurement signal for speed/angle of rotation
Grey (gy)	Measurement signal for speed/angle of rotation (90° phase-shifted)
Yellow (ye)	Cable shield to housing ground

3.5 Cable extension

Extension cables must be the shielded, low-capacitance type. We recommend the use of HBM cables that comply with these requirements.

When using cable extensions, ensure that the connection is perfect, with the lowest possible contact resistance and good insulation. For this reason all connections should be soldered, or at the very least should use firmly fixed terminals or screwed connectors.

Measurement cables should not be laid parallel to high-voltage lines or control circuits (and therefore should not be laid in common cable shafts). If this is not possible, protect the measurement cable with, for example, armoured steel tubing and keep them as far away as possible from other cables. Guard against stray fields from transformers, motors and contactors.

T4A cable extension:

The T4A torque/screw torque transducer uses a 4-wire connection technique. If you wish to add a cable extension, this must be carried out using the 6-wire connection technique. In this case the sensor circuits in the extension cable must be connected to the bridge excitation circuits of the transducer (for information on feedback bridges, see Fig.3.1).

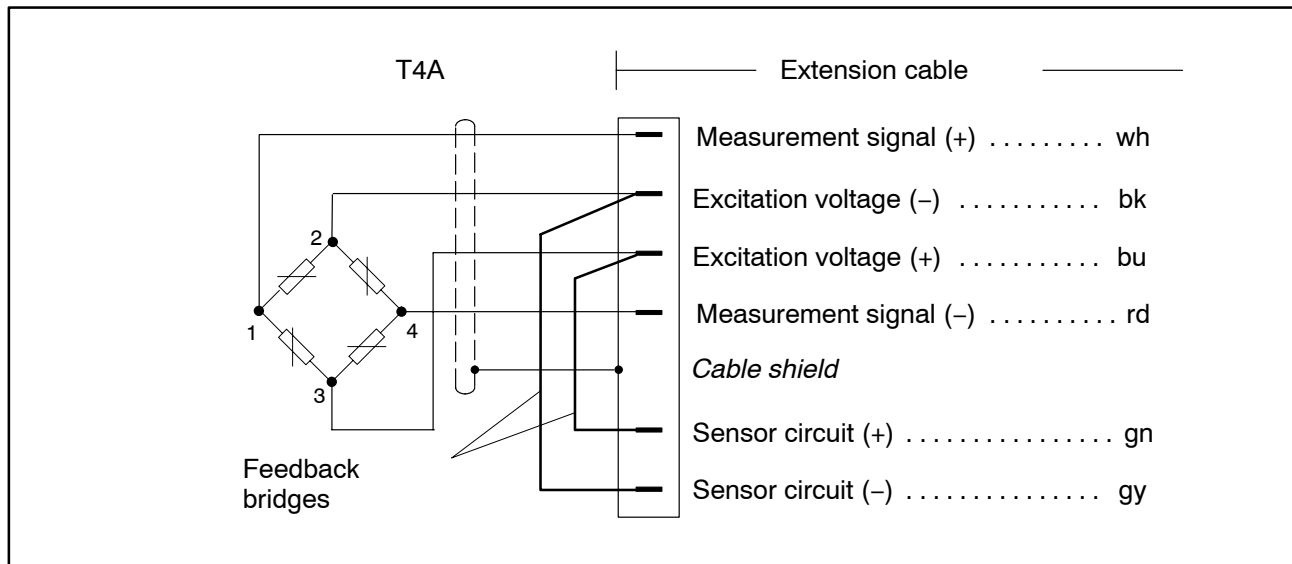

Fig.3.1: T4A cable extension

T4WA-S3 cable extension:

The T4WA-S3 torque/screw torque transducer uses the 6-wire connection technique. A cable extension can be added with no difficulty using 6-wire connection technique.

3.6 Shielding design

The cable shield is connected according to the HBM Greenline concept, thus enclosing the measuring system (without rotor) in a Faraday cage (for this it is important that the shielding on both cable ends is laid flat to the body of the casing) and preventing potential electromagnetic interference from affecting the measuring signal.

In the case of interferences due to potential differences (compensating currents), operating-voltage zero and housing ground must be disconnected on the amplifier and a potential-equilibration line between stator housing and amplifier housing must be established (copper conductor, 10 mm² wire cross-section).

4 Loading capacity

4.1 Maximum rotation speed

T4A, T4WA-S3 torque/screw torque transducer allow torque measurement at rotation speeds up to 4000 min⁻¹ (for information on maintenance intervals at the higher rotation speeds, see page 13).

4.2 Measuring dynamic torques

The T4A, T4WA-S3 torque/ screw torque transducer can be used to measure static and dynamic torques. The following applies for the measurement of dynamic torques:

- The calibration made for static measurements is also valid for dynamic torque measurements.

Note: The frequency of dynamic torque must not exceed the natural frequency of the mechanical measuring installation.

- The natural frequency f_0 for the mechanical measuring system depends on the moments of inertia J_1 and J_2 of the connected rotating masses and the transducers torsional stiffness.

Use the equation below to determine the natural frequency f_0 for the mechanical measuring system:

$$f_0 = \frac{1}{2\pi} \cdot \sqrt{c_T \cdot \left(\frac{1}{J_1} + \frac{1}{J_2} \right)}$$

f_0 = Natural frequency in Hz
 J_1, J_2 = Mass moment of inertia in kgm²
 c_T = Torsional stiffness in N·m/rad

- The maximum permissible amplitude of vibration (peak-to-peak) may be 70 % of the transducer's nominal torque, even with alternating load. The amplitude must be within the loading range defined by $-M_N$ and $+M_N$.

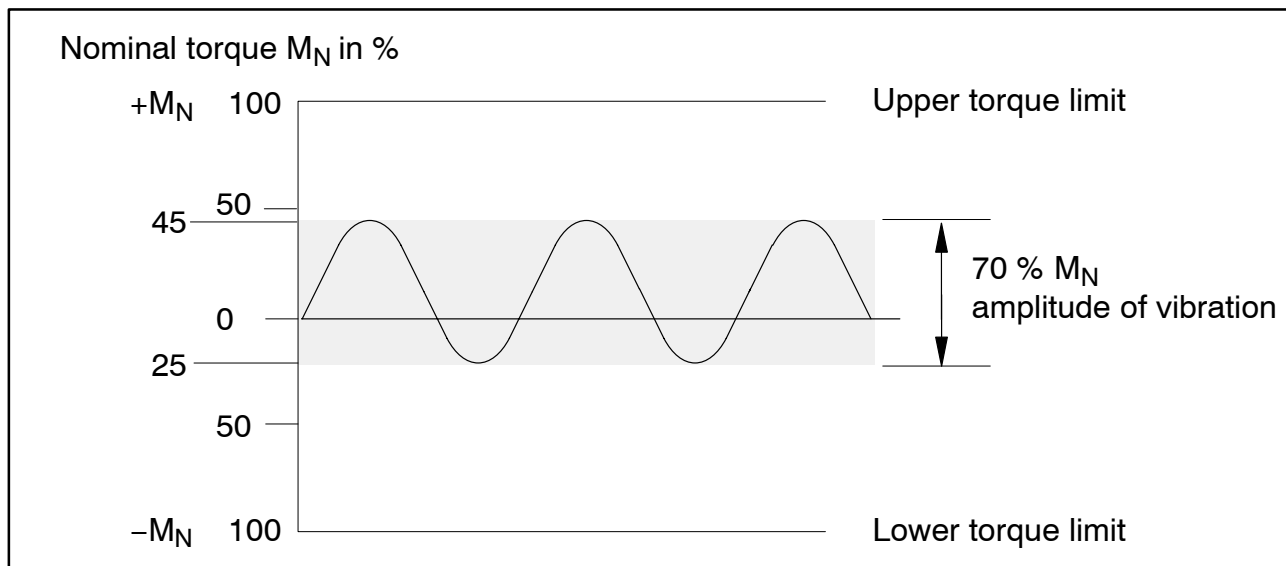

Fig. 4.1 Permissible dynamic loading

- When operating in the alternating load range, the internal and external squares on the torque/ screw torque transducer may be damaged by edge pressure. To avoid this, adjust the custom-fitted connection squares so that they are free of play.

5 Displaying torque and direction of rotation

Determining direction of rotation

The sign on the display indicates the direction of rotation. When HBM carrier-frequency or DC-voltage amplifiers are connected to the fitted cable, the output voltage or display is positive when the torque transducer will turn in direction of rotation **A** (see Fig. 5.1).

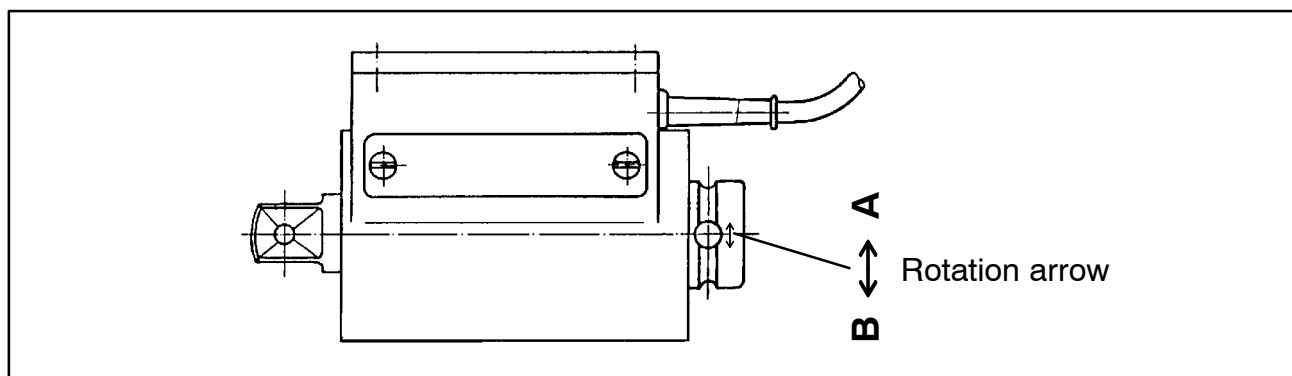

Fig. 5.1: Rotation arrow

Determining torque

If a right-handed torque is introduced (i.e. clockwise), a positive output signal (0...+10 V) is produced in conjunction with HBM measuring amplifiers.

6 Maintenance

The torque/ screw torque transducers are to a large extent maintenance-free. The only thing to watch for is the slight wear produced by the slip-rings and carbon-brushes.

The carbon-brushes produce dust which you should remove from the transducer housing for reasons of operating safety (see table 4). To do this, unscrew the side cover and carefully remove any carbon dust or dirt that has accumulated, using a fine brush and dry compressed air.

Replacement of the carbon-brushes and cleaning of the slotted disc must only be undertaken at our factory in Darmstadt.

T4A / T4WA-S3 [N·m]	Service life of brushes, approx. [revolutions]	Remove carbon-brush dust after [revolutions]
5; 10; 20; 50; 100; 200	3×10^8	1×10^7
500; 1000	6×10^8	2×10^8

Table 4: Maintenance



NOTE

Please note that the higher the rotation speed, the shorter the maintenance intervals.

Example:

Rotation speed 1500 min^{-1} (rpm) → Remove carbon-brush dust after approx. 111 hours.

Rotation speed 4000 min^{-1} (rpm) → Remove carbon-brush dust after approx. 42 hours.

7 Dimensions

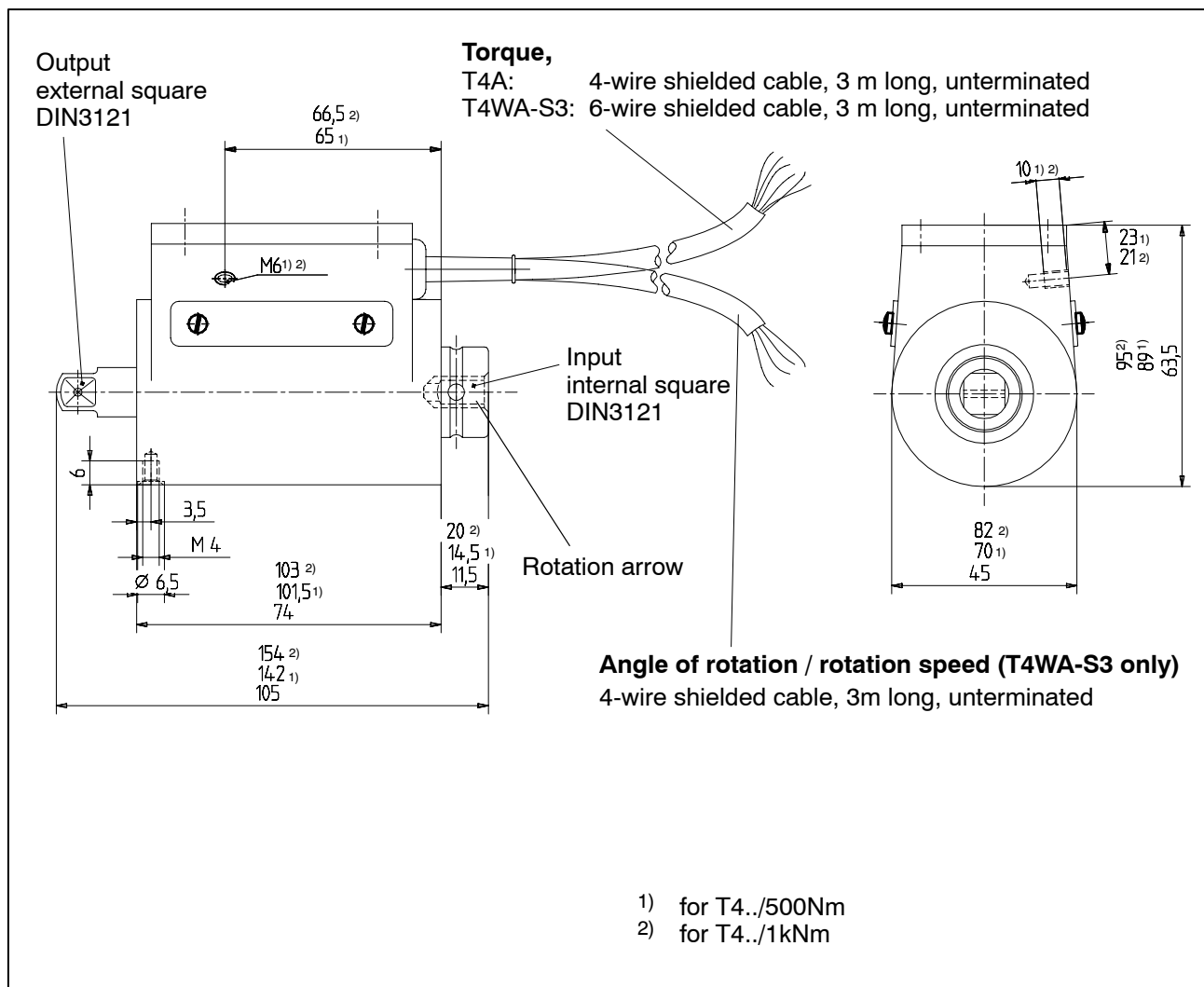

Type	Output	Input
T4A and T4WA-S3 5–50 N·m	3/8" External square DIN 3121–F10	3/8" Internal square DIN 3121–G10
T4A and T4WA-S3 100 N·m T4A and T4WA-S3 200 N·m	1/2" External square DIN 3121–F12.5	1/2" Internal square DIN 3121–G12.5
T4A and T4WA-S3 500 N·m	3/4" External square DIN 3121–F20	3/4" Internal square DIN 3121–H20
T4A and T4WA-S3 1 kN·m	1" External square DIN 3121–F25	1" Internal square DIN 3121–H25

8 Specifications

Type		T4A/T4WA-S3							
Accuracy class		0.2	0.1						
Nominal torque M_N	N·m	5	10	20	50	100	200	500	1000
Torque measuring system									
Nominal sensitivity (nominal signal range between torque=zero and nominal torque)	mV/V	2							
Characteristic tolerance (deviation of the actual output quantity at M_N from the nominal signal range)									
Effect of temperature per 10 K in nominal temp. range	%	< ± 0.2							
on the output signal (rel. to actual value of signal span)	%	< ± 0.1							
on the zero signal (rel. to nominal sensitivity)	%	< ± 0.1							
Linearity deviation including hysteresis (rel. to nominal sensitivity)	%	0.2	0.1						
Input resistance at reference temperature (T4A)	Ω	350 ± 1.8							
Torque measuring system of T4WA-S3	Ω	420 ± 40							
Output resistance at reference temperature	Ω	350 ± 1.5							
Maximum permissible excitation voltage	V	20							
Nominal range of the excitation voltage	V	0.5 ... 12							
Rotation speed/angle of rotation measurement system									
Measuring system		Optical, using infrared light and metal slotted disc							
Output signals	V	5, TTL level, 2xsquare wave signal 90° phase shifted							
Angle resolution (quadrilateral evaluation)	Deg.	1							
Number of mechanical increments		90							
Positional tolerance of increments	mm	± 0.05							
Slot width tolerance	mm	± 0.05							
Average optical diameter		approx. 31							
T4WA-S3/5 N·m...20 N·m		approx. 53							
T4WA-S3/500 N·m and 1 kN·m		4.8 ... 5.2							
Supply voltage	V _{DC}	4.8 ... 5.2							
Maximum current consumption	mA	50							
Reference temperature	°C [°F]	+23 [+73.4]							
Nominal temperature range	°C [°F]	+10...+60 [+50...+140]							
Operating temperature range	°C [°F]	-10...+60 [+14...+140]							
Storage temperature range	°C [°F]	-50...+70 [-58...+158]							

Mechanical values (rel. to nominal torque)									
Nominal torque M_N	N·m	5	10	20	50	100	200	500	1000
Torsional stiffness c_T	kN·m/ rad	0.29	0.61	1.08	2.42	5.57	7.53	27.3	65
Torsion angle at nominal torque M_N	Deg.	1	0.9	1.1	1.1	1.0	1.5	1.0	0.9
Mass moment of inertia $\times 10^{-3}$	kgm ²	0.04	0.04	0.04	0.04	0.04	0.04	0.28	0.44
Maximum permissible rotation speed	min ⁻¹	4000							
Service life of brushes, approx.	Rev.	3 × 10 ⁸						6 × 10 ⁸	
Carbon-brush dust removal, approx.	Rev.	1 × 10 ⁷						2 × 10 ⁸	
Static limit load	%	150					125		150
Static breaking load	%	300					200		300
Lateral limit force on shaft ¹⁾	N	5	10	20	50	80	125	235	370
Axial limit force on shaft ¹⁾	kN	0.35	0.7	2.0	3.5	5.5	8.8	16.4	25.9
Bending limit moment on shaft ¹⁾	N·m	0.75	1.5	3	6	11	23	57	114
Vibration bandwidth to DIN 50100 (by ref. to nom. torque) Upper and lower limits ²⁾	%	70 (peak-to-peak) + M_N or - M_N							
General									
Impact resistance, test severity level to DIN IEC68, Part 2-27; IEC 68-2-27-1987									
Number of		1000							
Duration	ms	3							
Acceleration (half-sine)	m/s ²	500							
Vibration resistance, test severity level to DIN IEC 68 part 2-6; IEC 68-2-27-1987									
Frequency range	Hz	5...65							
Duration	h	1.5							
Acceleration (amplitude)	m/s ²	50							
Weight, approx.	kg	0.4						1.8	2.4
Degree of protection to DIN IEC 60529		IP50							

¹⁾ Any irregular stress is only permissible up to the specified limits provided that none of the other stresses occurring at the time can also reach that value. If this condition is not met, the limit values must be reduced. If 30 % of the bending limit moment and lateral limit force occur at the same time, only 40 % of the axial limit force is permissible and nominal torque must not be exceeded. The permissible bending moments, axial forces and lateral forces can affect the measurement result by approx. 1 % of nominal torque.

²⁾ Nominal torque must not be exceeded.

9 Accessories

T4A Accessoires

- MS3106PEMV connection plug,
mounted on cable D-MS/MONT
- 15-pin D plug, mounted on cable D-15D/MONT

T4WA Accessoires

- 15 pin D plug, mounted on each cable,
assignment for AP01 D15D/MONT/MGC
- Adapter plug for angle-of-rotation channel
to MP60 assignment 1-15D/ADAP/PME
- Adapter plug for angle-of-rotation channel to Spider
assignment, including 5 V voltage control 1-15D/ADAP/SPIDER

10 Copy of Declaration of Conformity



**HÖTTINGER
BALDWIN
MESSTECHNIK**

HBM MESS- UND SYSTEMTECHNIK GMBH
Im Tiefen See 45 - D-64293 Darmstadt
Tel. ++49/6151/803-0, Fax. ++49/6151/894896

Konformitätserklärung

Declaration of Conformity

Déclaration de Conformité

Document: 136/06.1999

Wir,

We,

Nous,

HBM Mess- und Systemtechnik GmbH, Darmstadt

erklären in alleiniger Verantwortung,
daß das Produkt

declare under our sole
responsibility that the product

déclarons sous notre seule
responsabilité que le produit

Drehmoment- / Schraubmeßwelle T4WA-S3

auf das sich diese Erklärung
bezieht, mit der/den folgenden
Norm(en) oder normativen
Dokument(en) übereinstimmt (siehe
Seite 2) gemäß den Bestimmungen
der Richtlinie(n)

to which this declaration relates is
in conformity with the following
standard(s) or other normative
document(s) (see page 2)
following the provisions of
Directive(s)

Auquel se réfère cette déclaration
est conforme à la (aux) norme(s) ou
autre(s) document(s) normatif(s)
(voir page 2) conformément aux
dispositions de(s) Directive(s)

89/336/EWG - Richtlinie des Rates vom 3. Mai 1989 zur Angleichung der Rechtsvorschriften der Mitgliedsstaaten über die elektromagnetische Verträglichkeit, geändert durch 91/263/EWG, 92/31/EWG und 93/68/EWG

Die Absicherung aller produkt-spezifischen Qualitätsmerkmale erfolgt auf Basis eines von der DQS (Deutsche Gesellschaft zur Zertifizierung von Qualitätsmanagementsystemen) seit 1986 zertifizierten Qualitätsmanagementsystems nach DIN ISO 9001 (Reg.Nr. DQS-10001).

Die Überprüfung der sicherheitsrelevanten Merkmale (Elektromagnetische Verträglichkeit, Sicherheit elektrischer Betriebsmittel) führt ein von der DATech erstmals 1991 akkreditiertes Prüflaboratorium (Reg.Nr. DAT-P-006 und DAT-P-012) unabhängig im Hause HBM durch.

All product-related features are secured by a quality system in accordance with DIN ISO 9001, certified by DQS (Deutsche Gesellschaft zur Zertifizierung von Qualitätsmanagementsystemen) since 1986 (Reg. No. DQS-10001). The safety-relevant features (electromagnetic compatibility, safety of electrical apparatus) are verified at HBM by an independent testing laboratory which has been accredited by DATech in 1991 for the first time (Reg. Nos. DAT-P-006 and DAT-P-012).

Chez HBM, la détermination de tous les critères de qualité relatifs à un produit spécifique est faite sur la base d'un protocole DQS (Deutsche Gesellschaft zur Zertifizierung von Qualitätsmanagementsystemen) certifiant, depuis 1986, notre système d'assurance qualité selon DIN ISO 9001 (Reg.Nr. DQS-10001).

De même, tous les critères de protection électrique et de compatibilité électromagnétique sont certifiés par un laboratoire d'essais indépendant et accrédité depuis 1991 (Reg.Nr. DAT-P-006 et DAT-P-012).

Darmstadt, 13.07.1999

0V1051A1.03

Seite 2 zu

Page 2 of

Page 2 du

Document: 136/06.1999

Diese Erklärung bescheinigt die Übereinstimmung mit den genannten Richtlinien, beinhaltet jedoch keine Zusicherung von Eigenschaften. Die Sicherheitshinweise der mitgelieferten Produktdokumentation sind zu beachten.

This declaration certifies conformity with the Directives listed above, but is no asseveration of characteristics. Safety directions of the delivered product documentation have to be followed.

Cette déclaration atteste la conformité avec les directives citées mais n'assure pas un certain caractère. S.v.p. observez les indications de sécurité de la documentation du produit ajoutée.

Folgende Normen werden zum Nachweis der Übereinstimmung mit den Vorschriften der Richtlinie(n) eingehalten:

The following standards are fulfilled as proof of conformity with the provisions of the Directive(s):

Pour la démonstration de la conformité aux disposition de(s) Directive(s) le produit satisfait les normes:

EN 50082-2 : 1995

Elektromagnetische Verträglichkeit (EMV); Fachgrundnorm Störfestigkeit; Teil 2: Industriebereich; Deutsche Fassung

EN 55011 : 1998

Funk-Entstörung von Elektrischen Betriebsmitteln und Anlagen; Grenzwerte und Meßverfahren für Funkstörungen von industriellen, wissenschaftlichen und medizinischen Hochfrequenzgeräten (ISM-Geräten) (CISPR 11 : 1997, modifiziert); Deutsche Fassung; Klasse B

CV1051A1.03

Modifications reserved.
All details describe our products in general form only. They are not to be understood as express warranty and do not constitute any liability whatsoever.

Hottinger Baldwin Messtechnik GmbH

Postfach 10 01 51, D-64201 Darmstadt
Im Tiefen See 45, D-64293 Darmstadt
Tel.: +49/61 51/ 8 03-0; Fax: +49/61 51/ 8039100
E-mail: support@hbm.com www.hbm.com



measurement with confidence