

# T40B

## Torque flange



### Special features

- Nominal (rated) torques 200 N·m, 500 N·m, 1 kN·m, 2 kN·m, 3 kN·m, 5 kN·m and 10 kN·m
- Nominal (rated) rotational speeds of 10,000 rpm to 20,000 rpm
- Accuracy class 0.05
- Large measurement frequency range up to 6 kHz (-3 dB)
- Digital transmission of measured values
- Compact design
- Low rotor weights and mass moments of inertia
- Optional: Rotational speed measuring system

### Overall concept

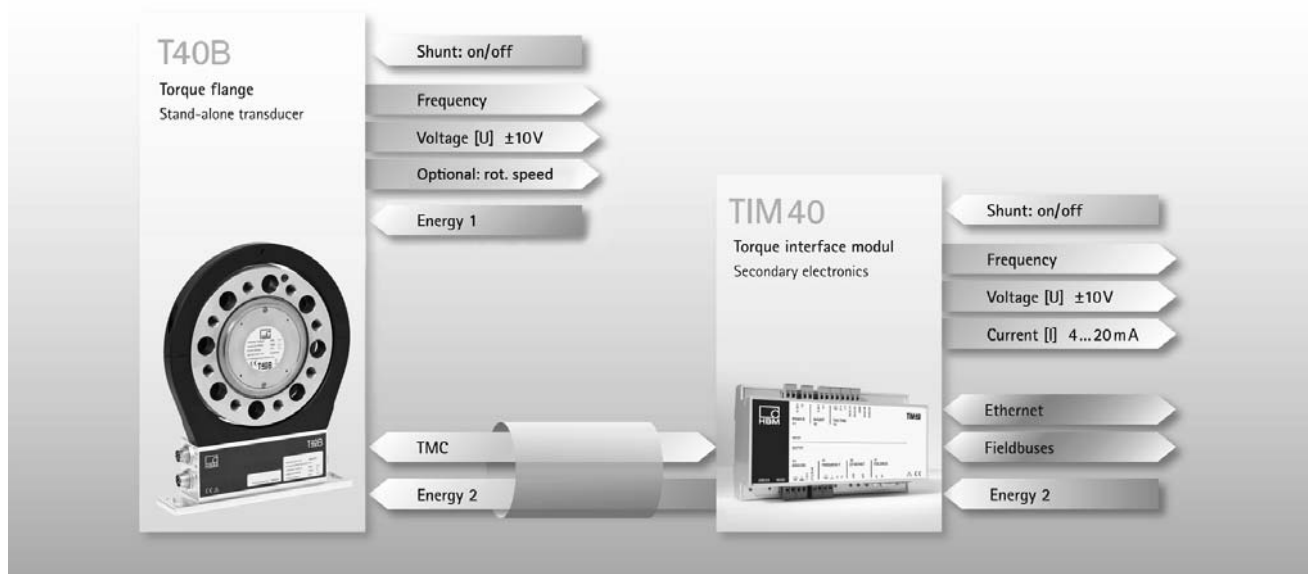

# Specifications

Type		T40B						
Accuracy class		0.05						
Torque measuring system								
Nominal (rated) torque $M_{nom}$	N·m	200	500					
	kN·m			1	2	3	5	10
<b>Nominal (rated) sensitivity</b> (spread between torque = zero and nominal (rated) torque) Frequency output 10 kHz / 60 kHz / 240 kHz Voltage output <b>Sensitivity tolerance</b> (deviation of the actual output quantity at $M_{nom}$ from the nominal (rated) sensitivity) Voltage output	kHz	5/30/120						
	V	10						
	%	± 0.1						
<b>Output signal at torque = zero</b> Frequency output Voltage output	kHz	10/60/240						
	V	0						
<b>Nominal output signal</b> Frequency output with positive nominal (rated) torque with negative nominal (rated) torque Voltage output with positive nominal (rated) torque with negative nominal (rated) torque	kHz	15 <sup>1)</sup> / 90 <sup>2)</sup> / 360 <sup>3)</sup> (5 V symmetrical <sup>4)</sup> )						
	kHz	5 <sup>1)</sup> / 30 <sup>2)</sup> / 120 <sup>3)</sup> (5 V symmetrical <sup>4)</sup> )						
	V	+10						
	V	-10						
<b>Load resistance</b> Frequency output Voltage output	kΩ	≥ 2						
	kΩ	≥ 10						
<b>Longterm drift over 48 h</b> Frequency output Voltage output	%	< ± 0.03						
	%	< ± 0.03						
<b>Measurement frequency range, -3 dB</b> kHz		1 <sup>1)</sup>						
		3 <sup>2)</sup>						
<b>Group delay</b> μs		< 400 <sup>1)</sup>						
		< 220 <sup>2)</sup>						
		< 150 <sup>3)</sup>						
<b>Residual ripple</b> Voltage output <sup>5)</sup>	mV	< 40						
<b>Effect of temperature per 10 K in the nominal (rated) temperature range on the output signal, relative to the actual value of the signal spread</b> Frequency output Voltage output <b>on the zero signal, relative to the nominal (rated) sensitivity</b> Frequency output Voltage output	%	± 0.05						
	%	± 0.2						
	%	± 0.05						
	%	± 0.1						
<b>Maximum modulation range<sup>6)</sup></b> Frequency output Voltage output	kHz	2.5 ... 17.5 <sup>1)</sup> / 15 ... 105 <sup>2)</sup> / 60 ... 420 <sup>3)</sup>						
	V	-12 ... +12						
<b>Energy supply</b> Nominal (rated) supply voltage (separated extra-low DC voltage) Current consumption in measuring mode Current consumption in startup mode Nominal (rated) power consumption Maximum cable length	V	18 ... 30						
	A	< 1						
	A	< 4 (typ. 2) 50 μs						
	W	< 10						
	m	50						

1) Option 5, 10 ± 5 kHz (code SU2)

2) Option 5, 60 ± 30 kHz (code DU2)

3) Option 5, 240 ± 120 kHz (code HU2)

4) RS-422 complementary signals, note termination resistor.

5) Signal frequency range 0.1 to 10 kHz

6) Output signal range in which there is a repeatable correlation between torque and output signal.

## Specifications (continued)

Nominal (rated) torque $M_{nom}$	N·m	200	500					
	kN·m			1	2	3	5	10
<b>Non-linearity including hysteresis,</b> relative to the nominal (rated) sensitivity								
Frequency output	%	< ± 0.03						
Voltage output	%	< ± 0.03						
<b>Relative standard deviation of repeatability</b> per DIN 1319, relative to the variation of the output signal								
Frequency output	%	< ± 0.03						
Voltage output	%	< ± 0.03						
<b>Shunt signal</b>		approx. 50 % of $M_{nom}$						
<b>Tolerance of the shunt signal, relative to <math>M_{nom}</math></b>	%	< ± 0.05						
Nominal (rated) trigger voltage	V	5						
Trigger voltage limit	V	36						
Shunt signal ON	V	min. > 2.5						
Shunt signal OFF	V	max. < 0.7						
<b>Rotational speed measuring system</b>								
<b>Measurement system</b>		Magnetic, via AMR sensor (Anisotropic Resistive Effect) and magnetized plastic ring with embedded steel ring						
<b>Magnetic poles</b>		72	86	108	126	156		
<b>Maximum position deviation of the poles</b>		± 50 angular seconds						
<b>Output signal</b>	V	5 V symmetrical (RS-422); 2 square wave signals approx. 90° phase shifted						
<b>Pulses per revolution</b>		1024						
<b>Minimum rotational speed for sufficient pulse stability</b>	rpm	0						
<b>Pulse tolerance <sup>7)</sup></b>	degrees	< ± 0.05						
<b>Maximum permissible output frequency</b>	kHz	420						
<b>Group delay</b>	µs	< 150						
<b>Radial nominal (rated) distance between sensor head and magnetic ring</b> (mechanical distance)	mm	1.6						
<b>Working distance range between sensor head and magnetic ring</b>	mm	0.4 ... 2.5						
<b>Max. permissible axial displacement of the rotor to the stator <sup>8)</sup></b>	mm	± 1.5						
<b>Hysteresis of reversing the direction in the case of relative vibrations between the rotor and the stator</b>								
Torsional vibration of the rotor	degrees	< approx. 0.2						
Horizontal stator vibration displacement	mm	< approx. 0.5						
<b>Magnetic load limit</b>								
Remanent flux density	mT	> 100						
Coercive field strength	kA/m	> 100						
<b>Permissible magnetic field strength for signal deviations</b>	kA/m	< 0.1						
<b>Load resistance <sup>9)</sup></b>	kΩ	≥ 2						

<sup>7)</sup> At nominal (rated) conditions.

<sup>8)</sup> The data refers only to a central axial alignment. Deviations lead to a change in pulse tolerance.

<sup>9)</sup> Note the termination resistances as per RS-422.

General information								
<b>EMC</b>								
<b>Emission</b> (per EN 61326-1, Section 7) RFI field strength	-	Class B						
<b>Immunity from interference</b> (EN 61326-1, Table 2)								
Electromagnetic field (AM)	V/m	10						
Magnetic field	A/m	100						
Electrostatic discharge (ESD)								
Contact discharge	kV	4						
Air discharge	kV	8						
Fast sweeps (burst)	kV	1						
Impulse voltages (surge)	kV	1						
Conducted interference (AM)	V	10						
<b>Degree of protection per EN 60529</b>								
		IP 54						
<b>Reference temperature</b>								
	°C	23						
<b>Nominal temperature range</b>								
	°C	+10 ... +70						
<b>Operating temperature range</b>								
	°C	-20 ... +85						
<b>Storage temperature range</b>								
	°C	-40 ... +85						
<b>Mechanical shock per EN 60068-2-27<sup>10)</sup></b>								
Number	n	1000						
Duration	ms	3						
Acceleration (half sine)	m/s <sup>2</sup>	650						
<b>Vibrational stress in 3 directions per EN 60068-2-6<sup>10)</sup></b>								
Frequency range	Hz	10 ... 2000						
Duration	h	2.5						
Acceleration (amplitude)	m/s <sup>2</sup>	200						
<b>Nominal (rated) rotational speed</b>								
	rpm	20,000	15,000	12,000	10,000			
<b>Load limits<sup>11)</sup></b>								
<b>Limit torque, relative to M<sub>nom</sub><sup>12)</sup></b>	%	200			160			
<b>Breaking torque, relative to M<sub>nom</sub><sup>12)</sup></b>	%	> 400			> 320			
<b>Longitudinal limit force<sup>13)</sup></b>	kN	10	13	19	30	35	60	80
<b>Lateral limit force<sup>13)</sup></b>	kN	2	4	5	9	10	12	18
<b>Limit bending moment<sup>13)</sup></b>	N·m	100	200	220	560	600	800	1200
<b>Oscillation width per DIN 50100 (peak-to-peak)<sup>14)</sup></b>	N·m	400	1000	2000	4000	4800	8000	16000

<sup>10)</sup> The antenna ring and connection plug must be fixed in place.

<sup>11)</sup> Each type of irregular stress (bending moment, lateral or longitudinal force, exceeding nominal (rated) torque), can only be permitted up to its specified load limit, provided none of the others can occur at the same time. If this condition is not met, the limit values must be reduced. If 30% of the limit bending moment and lateral limit force occur at the same time, only 40% of the longitudinal limit force is permissible and the nominal (rated) torque must not be exceeded. The permissible bending moments, longitudinal forces and lateral forces can affect the measurement result by approx. 0.3 % of the nominal (rated) torque. The load limits only apply for the nominal (rated) temperature range. At temperatures < 10 °C, load limits are expected to reduce by up to 30%, because there is an increased reduction in toughness as temperatures fall.

<sup>12)</sup> With static loading.

<sup>13)</sup> Static and dynamic.

<sup>14)</sup> The nominal (rated) torque must not be exceeded.

## Specifications (continued)

Nominal (rated) torque $M_{nom}$	N·m	200	500					
	kN·m			1	2	3	5	10
<b>Mechanical values</b>								
Torsional stiffness $c_T$	kN·m/rad	360	745	1165	2515	3210	5565	14335
Torsion angle at $M_{nom}$	degrees	32	0.038	0.049	0.046	0.054	0.051	0.040
Stiffness in the axial direction $c_a$	kN/mm	540	450	580	540	570	760	960
Stiffness in the radial direction $c_r$	kN/mm	315	560	860	1365	1680	2080	2940
Stiffness with bending moment round a radial axis $c_b$	kN·m/deg.	3.6	4.2	5.9	9	9.3	20.2	45.5
Maximum deflection at longitudinal limit force	mm	< 0.04	< 0.05		< 0.06		< 0.08	< 0.09
Additional max. radial run-out deviation at lateral limit force	mm	< 0.02						
Additional plumb/parallel deviation at limit bending moment (at $\varnothing d_B$ )	mm	< 0.06	< 0.11	< 0.09	< 0.18	< 0.19	< 0.14	< 0.12
Balance quality level per DIN ISO 1940		G 2.5						
<b>Max. permissible vibration displacement of the rotor (peak-to-peak)<sup>15)</sup></b> Undulation in the connection flange area following ISO 7919-3								
Normal operation (continuous operation)	$\mu\text{m}$	$s_{(p-p)} = \frac{9000}{\sqrt{n}}$ (n in rpm)						
Start and stop operation/resonance ranges (temporary)	$\mu\text{m}$	$s_{(p-p)} = \frac{13200}{\sqrt{n}}$ (n in rpm)						
<b>Mass moment of inertia of the rotor <math>J_v</math></b>								
without rotational speed measuring system	kg·m <sup>2</sup>	0.0017	0.0039	0.0128		0.0292	0.0771	
with magn. rotational speed measuring system	kg·m <sup>2</sup>	0.0022	0.0048	0.0145	0.0146	0.0333	0.0872	
<b>Proportional mass moment of inertia for the transmitter side (side of the flange with external centering)</b>								
without rotational speed measuring system	% of $J_v$	62	59	54		53	54	
with magn. rotational speed measuring system	% of $J_v$	48	48	48		47	48	
<b>Max. permissible static eccentricity</b> of the rotor (radially) to the center point of the stator								
without rotational speed measuring system	mm	$\pm 2$						
<b>Permissible axial displacement</b> between rotor and stator <sup>16)</sup>								
without rotational speed measuring system	mm	$\pm 2$						
<b>Weight</b>								
Rotor without rotational speed measuring system	kg	1.1	1.9	3.8	3.9	6.5	10.9	
Rotor with magn. rotational speed measuring system	kg	1.3	2.1	4.1	4.1	6.9	11.7	
Stator	kg	1.1	1.1	1.1	1.1	1.2	1.3	

<sup>15)</sup> The influence of radial run-out deviations, eccentricity, defects of form, notches, marks, local residual magnetism, structural inhomogeneity or material anomalies needs to be taken into account and isolated from the actual undulation.

<sup>16)</sup> Above the nominal (rated) temperature range:  $\pm 1.5$  mm.

## Radial and axial run-out tolerances

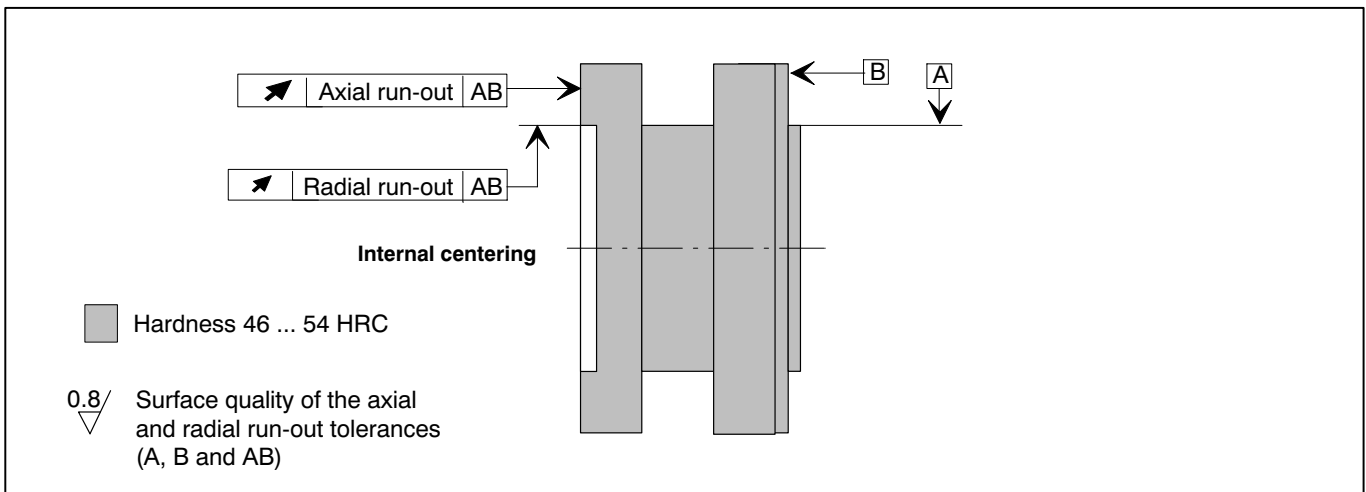

Measuring range (N·m)	Axial run-out tolerance (mm)	Radial run-out tolerance (mm)
200	0.01	0.01
500	0.01	0.01
1 k	0.01	0.01
2 k	0.02	0.02
3 k	0.02	0.02
5 k	0.02	0.02
10 k	0.02	0.02









# Dimensions of T40B/2 kNm and 3 kNm without rotational speed measurement

Dimensions in mm (1 mm = 0.03937 inches)

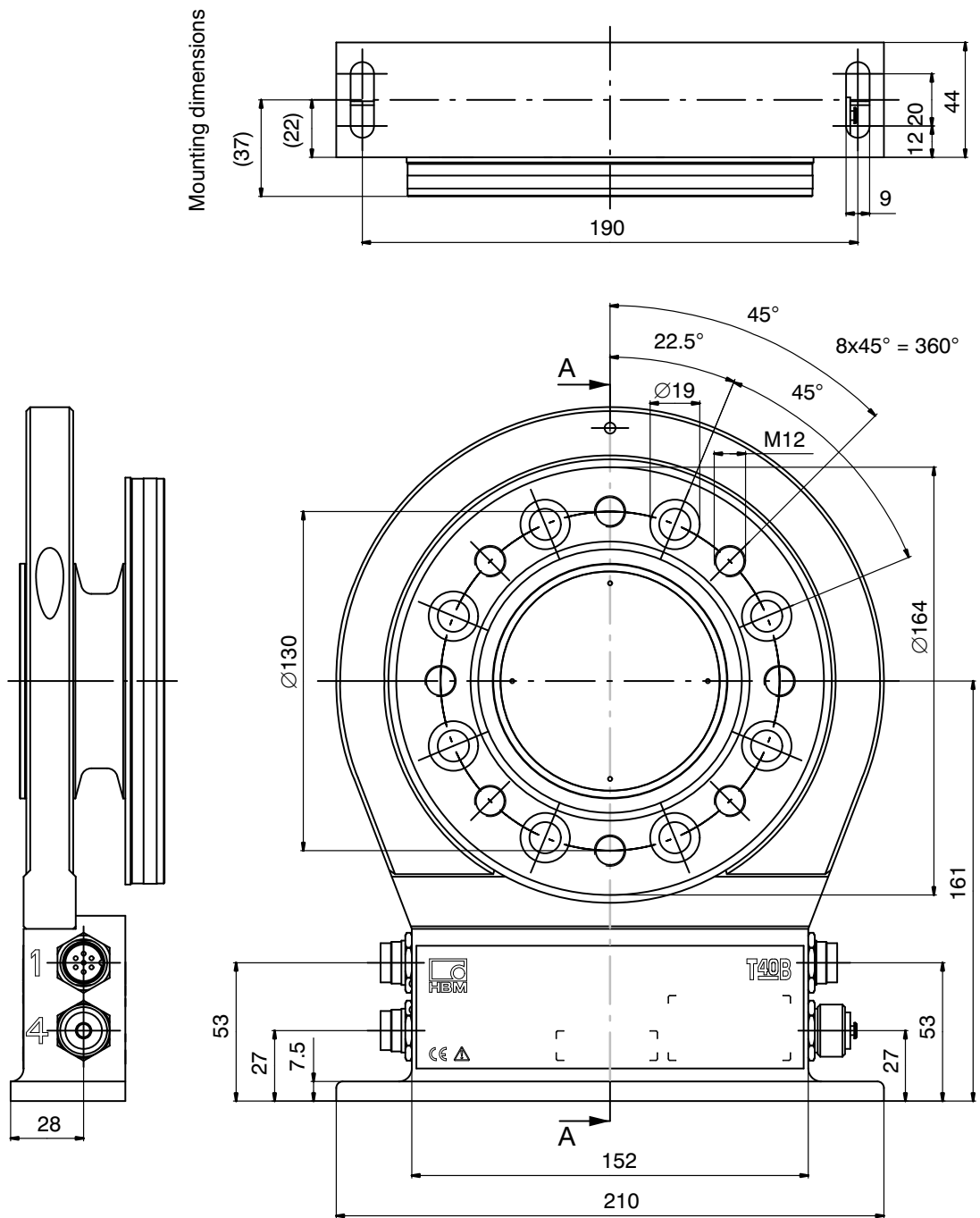

Dimensions of T40B/2 kNm and 3 kNm without rotational speed measurement, continued

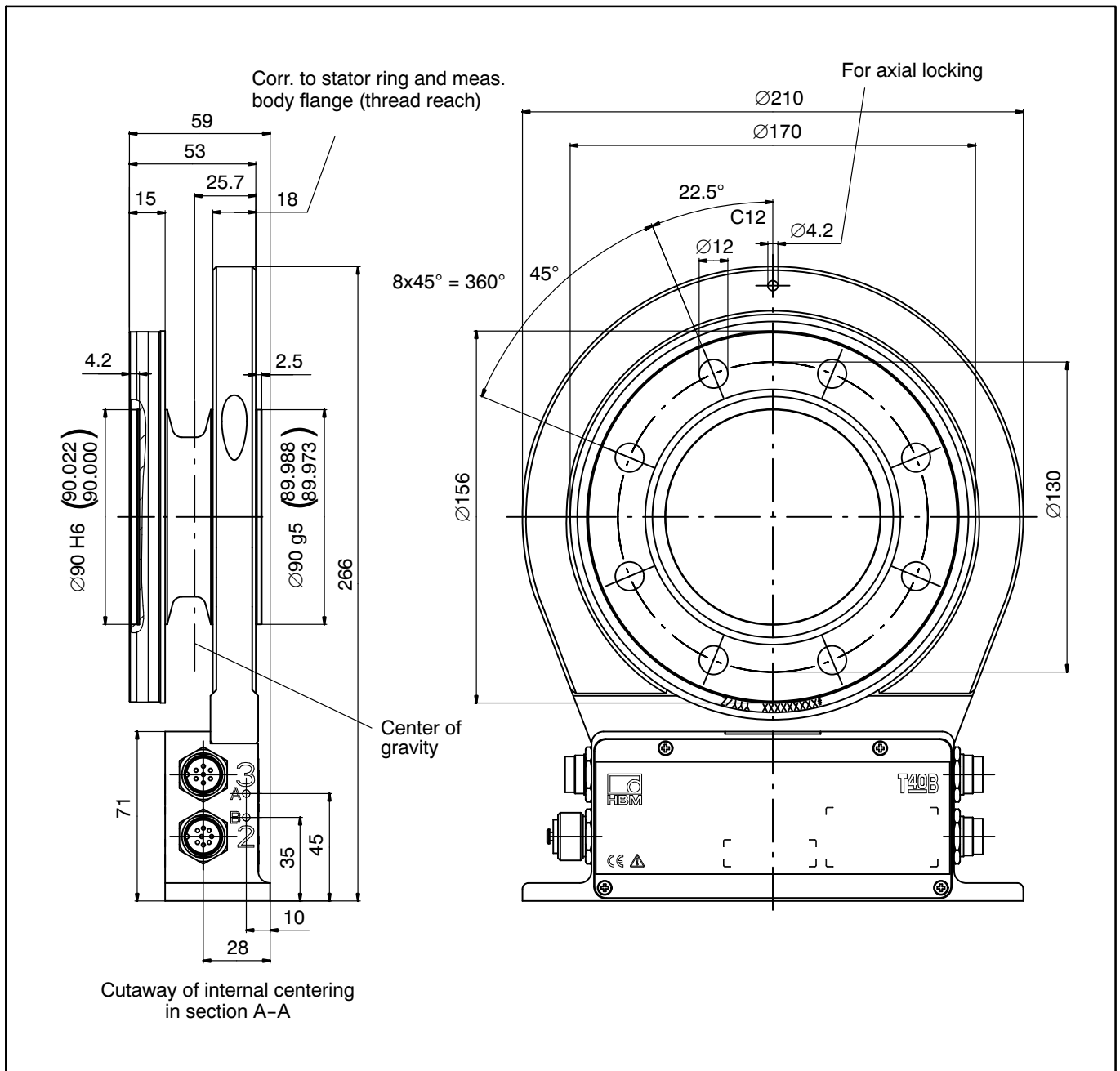

# Dimensions of T40B/5 kNm without rotational speed measurement

Dimensions in mm (1 mm = 0.03937 inches)

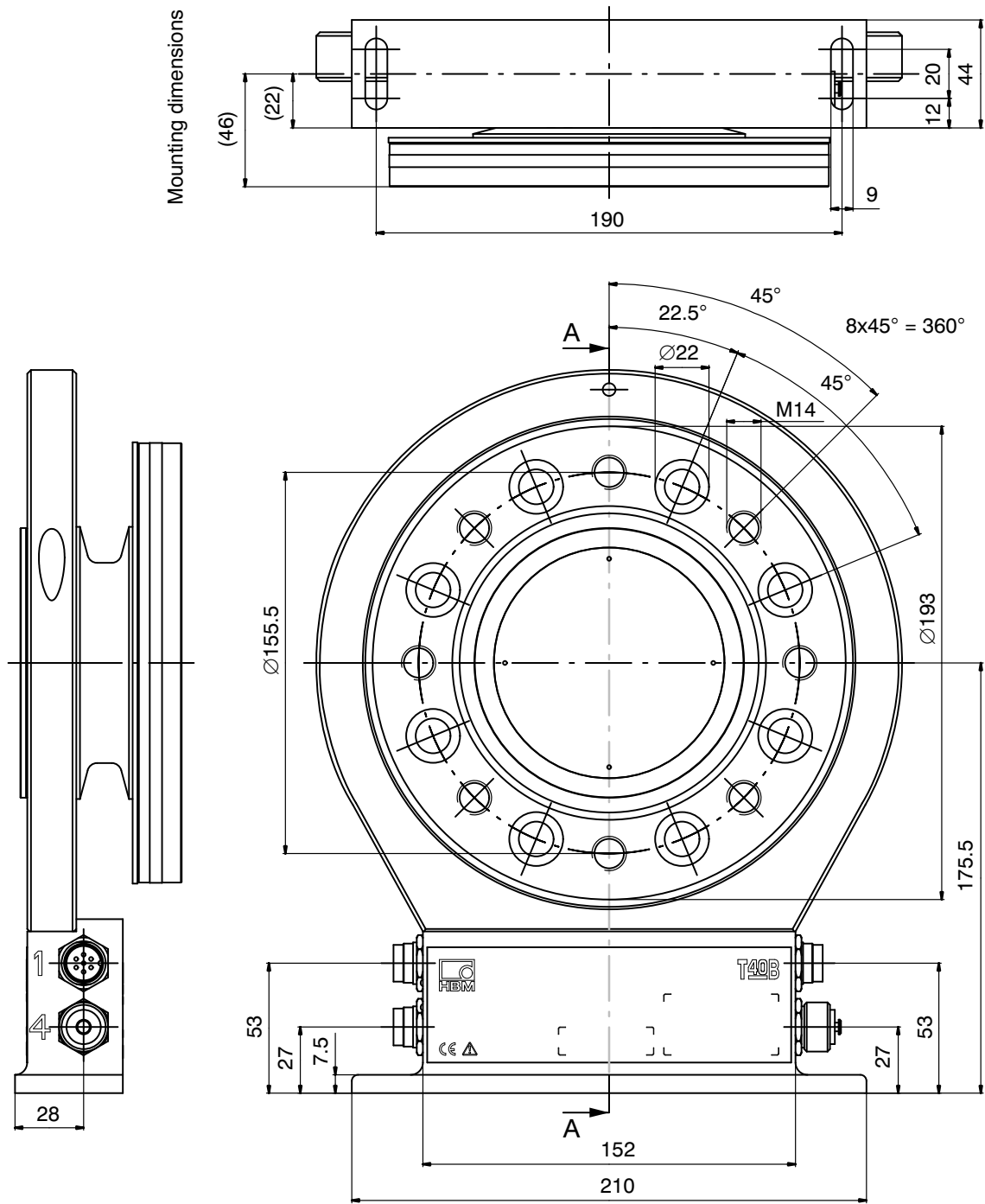

# Dimensions of T40B/5 kNm without rotational speed measurement, continued

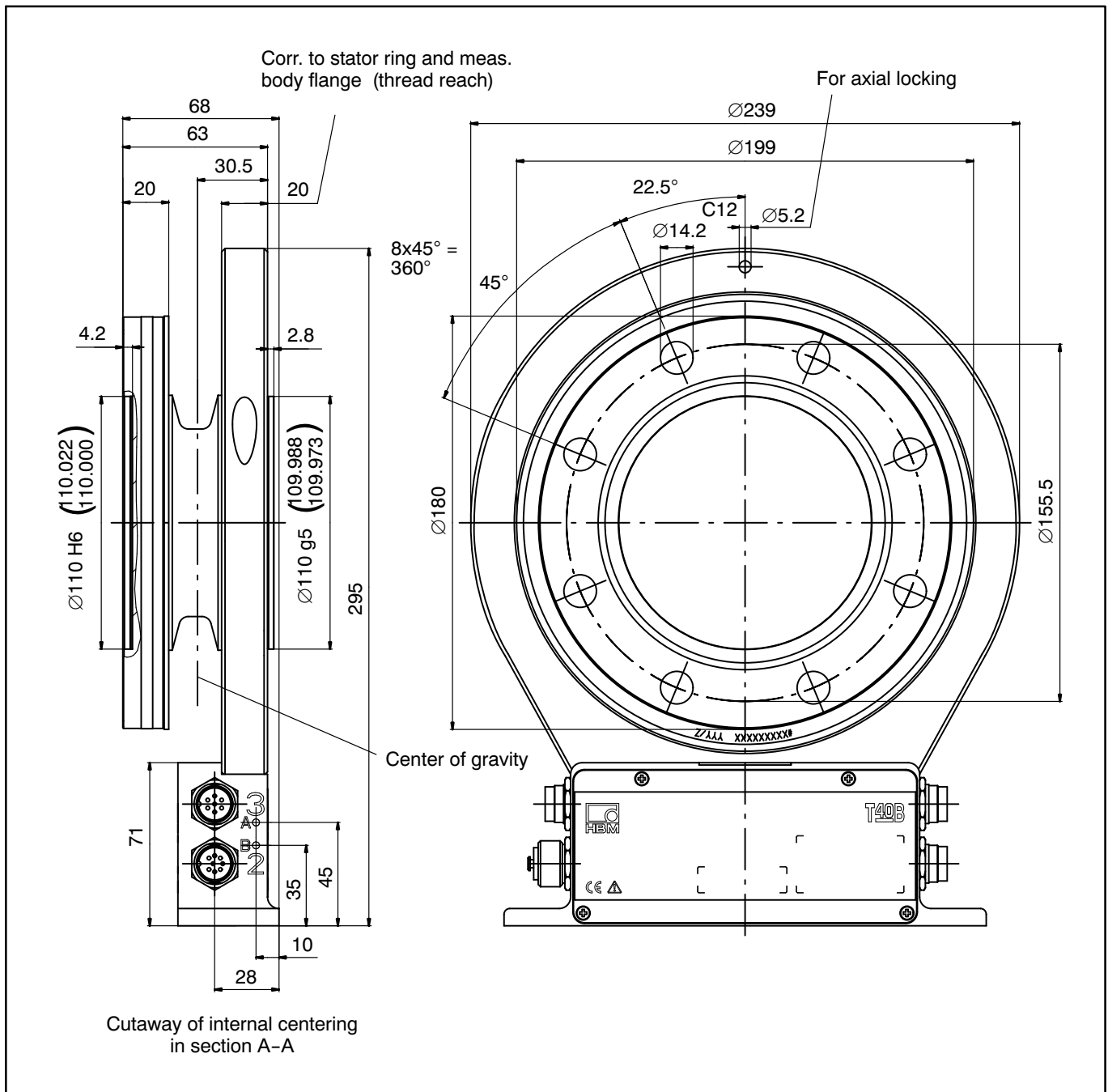

# Dimensions of T40B/10 kNm without rotational speed measurement

Dimensions in mm (1 mm = 0.03937 inches)

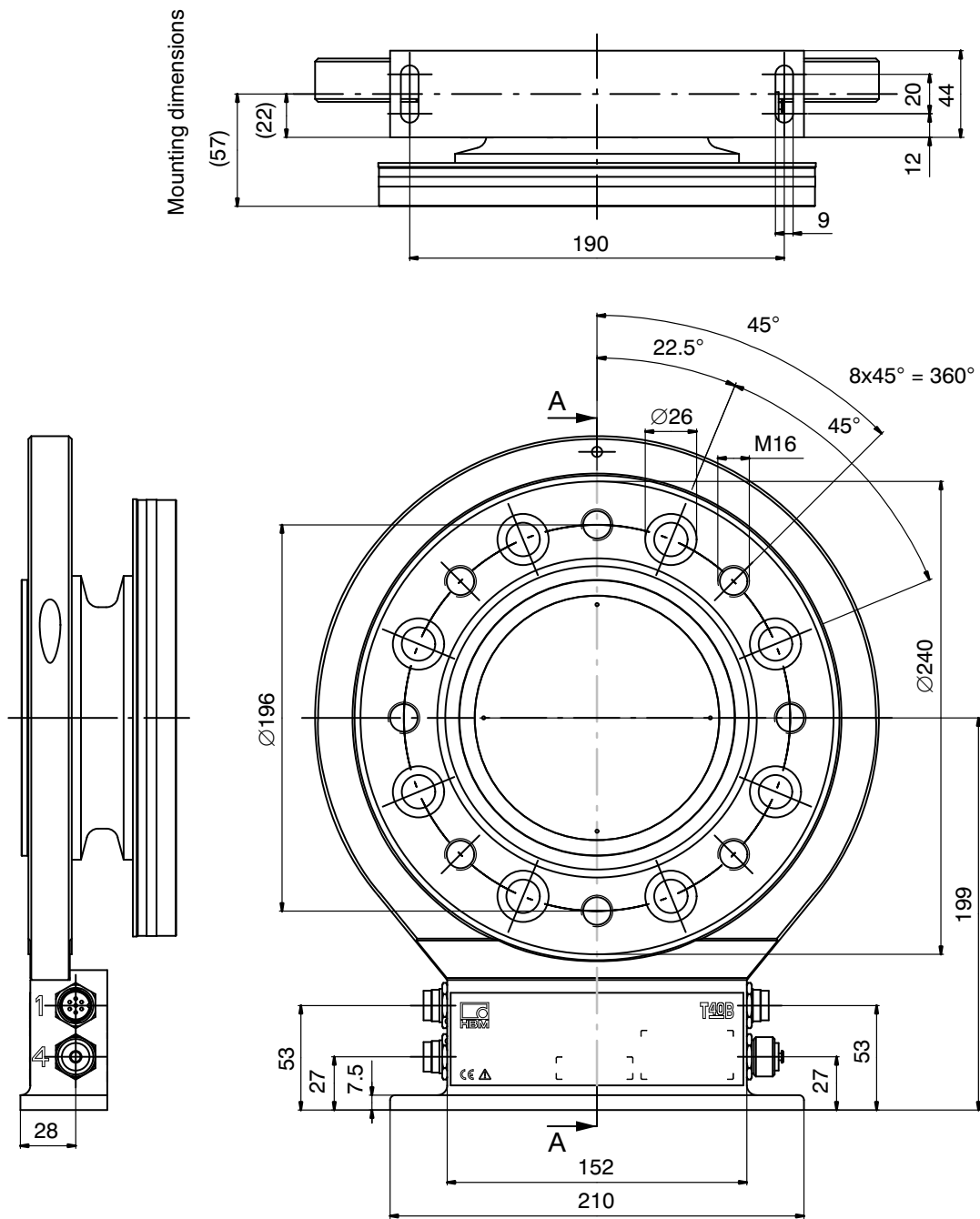



# Dimensions of T40B/200 Nm with rotational speed measurement

Dimensions in mm (1 mm = 0.03937 inches)

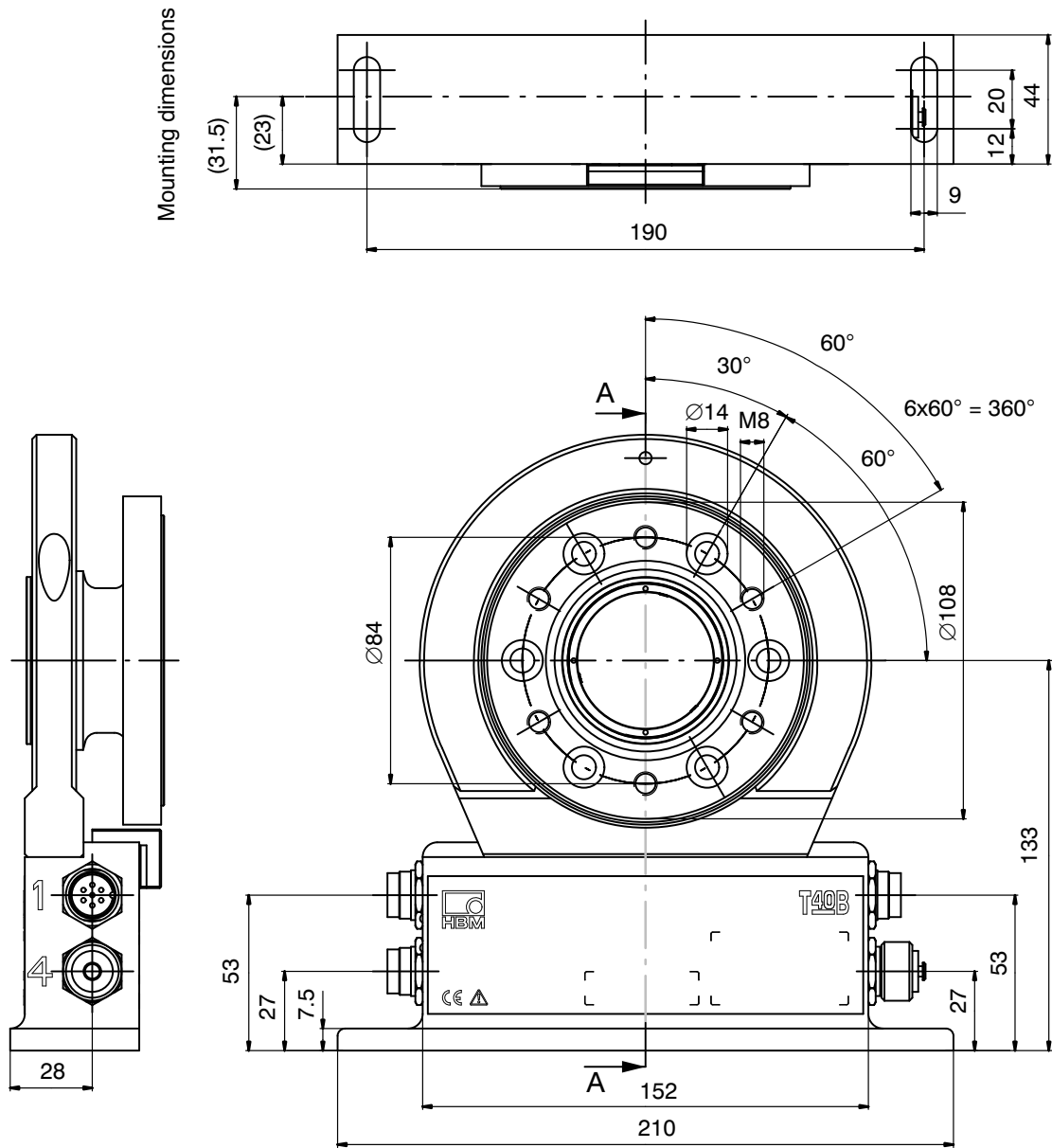





# Dimensions of T40B/500 Nm and 1 kNm with rotational speed measurement, continued

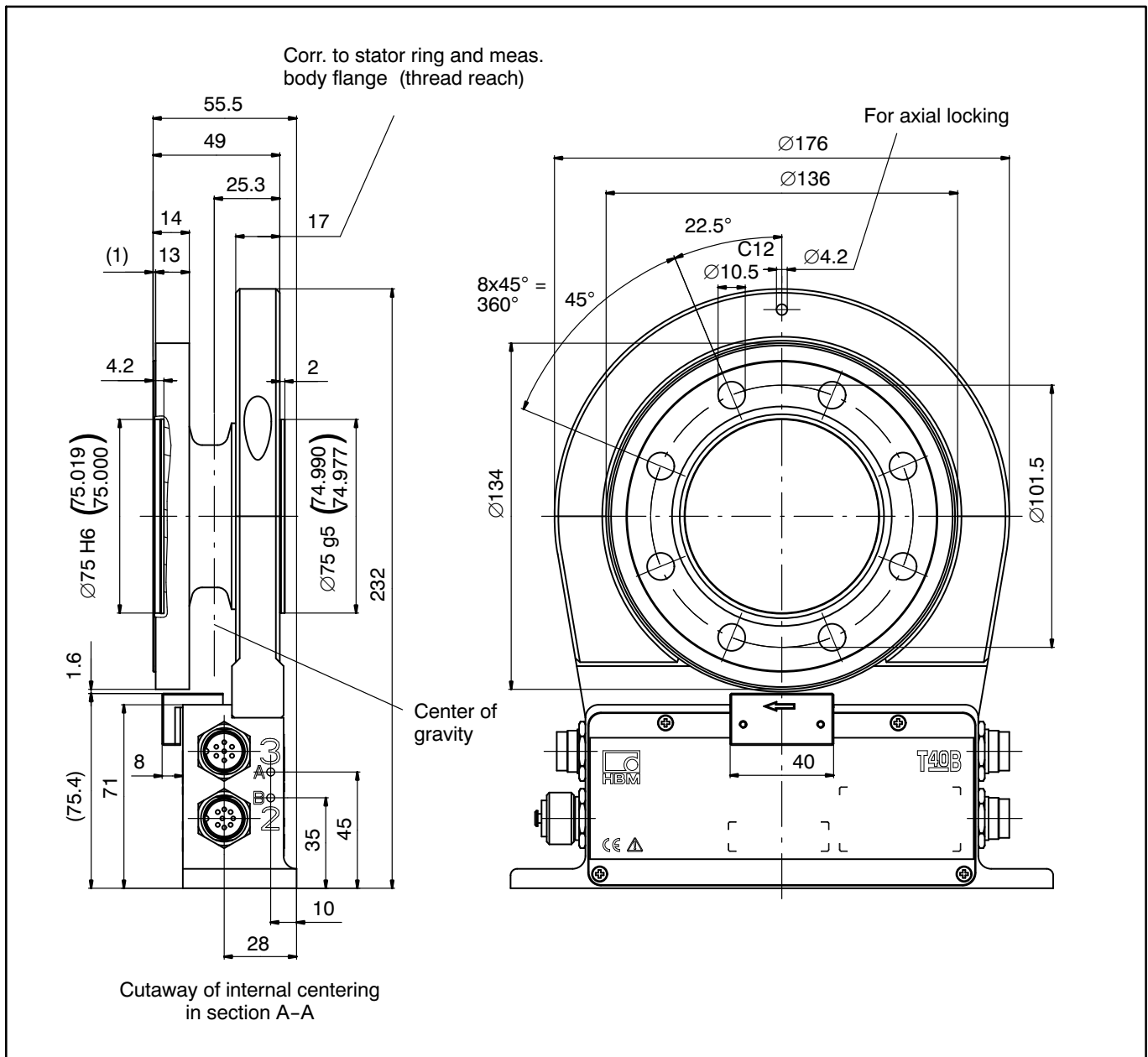

# Dimensions of T40B/2 kNm and 3 kNm with rotational speed measurement

Dimensions in mm (1 mm = 0.03937 inches)

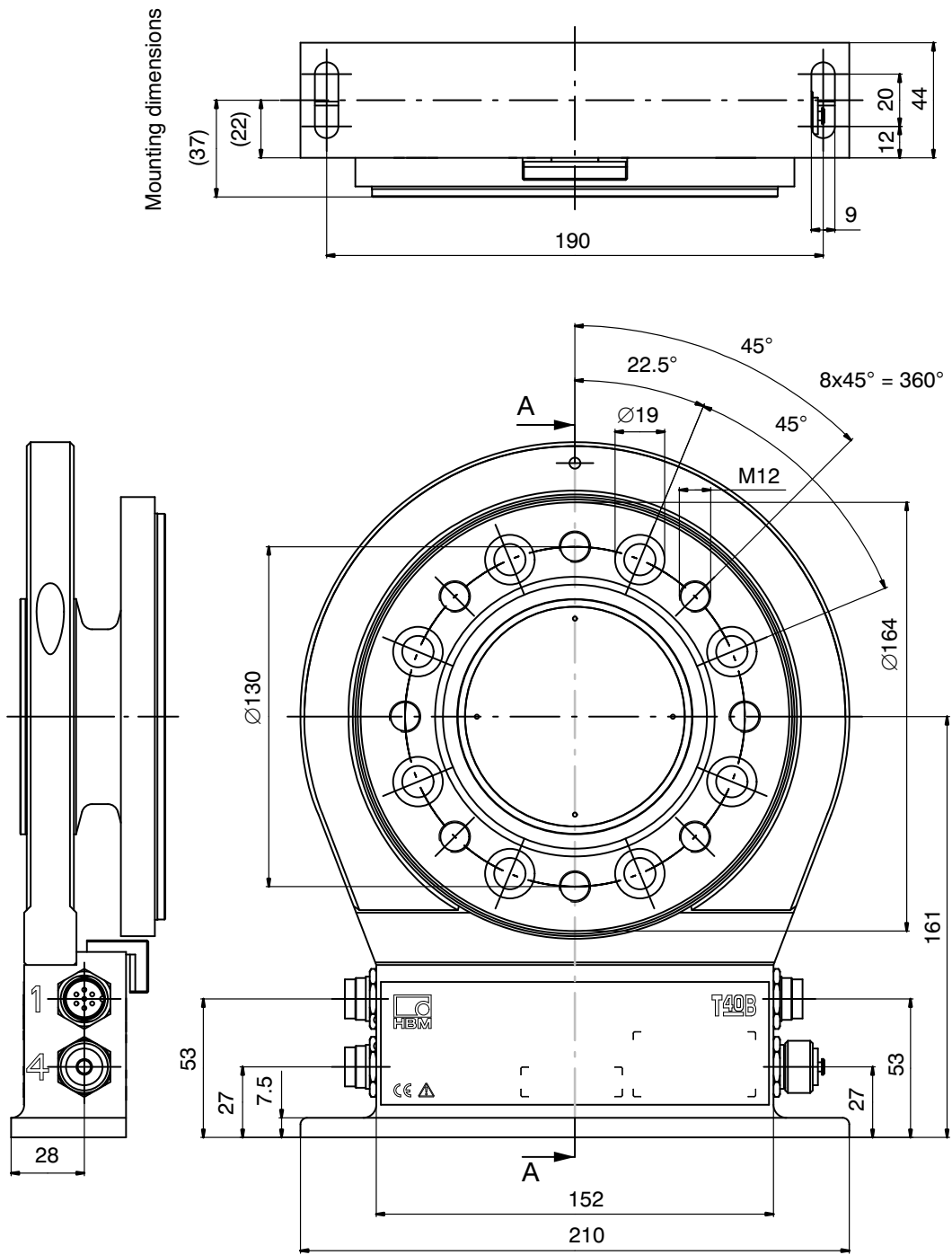

# Dimensions of T40B/2 kNm and 3 kNm with rotational speed measurement, continued

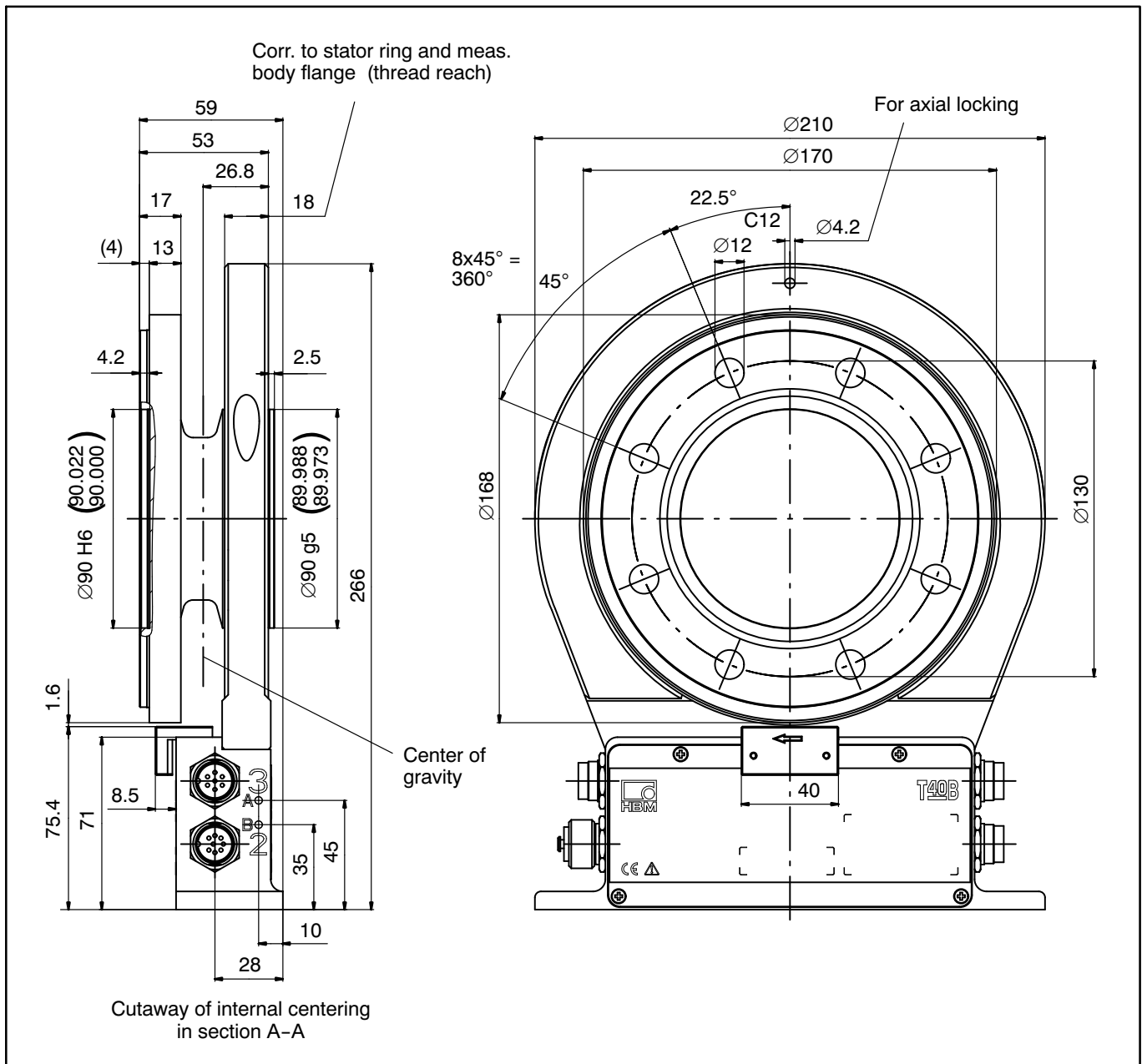

# Dimensions of T40B/5 kNm with rotational speed measurement

Dimensions in mm (1 mm = 0.03937 inches)

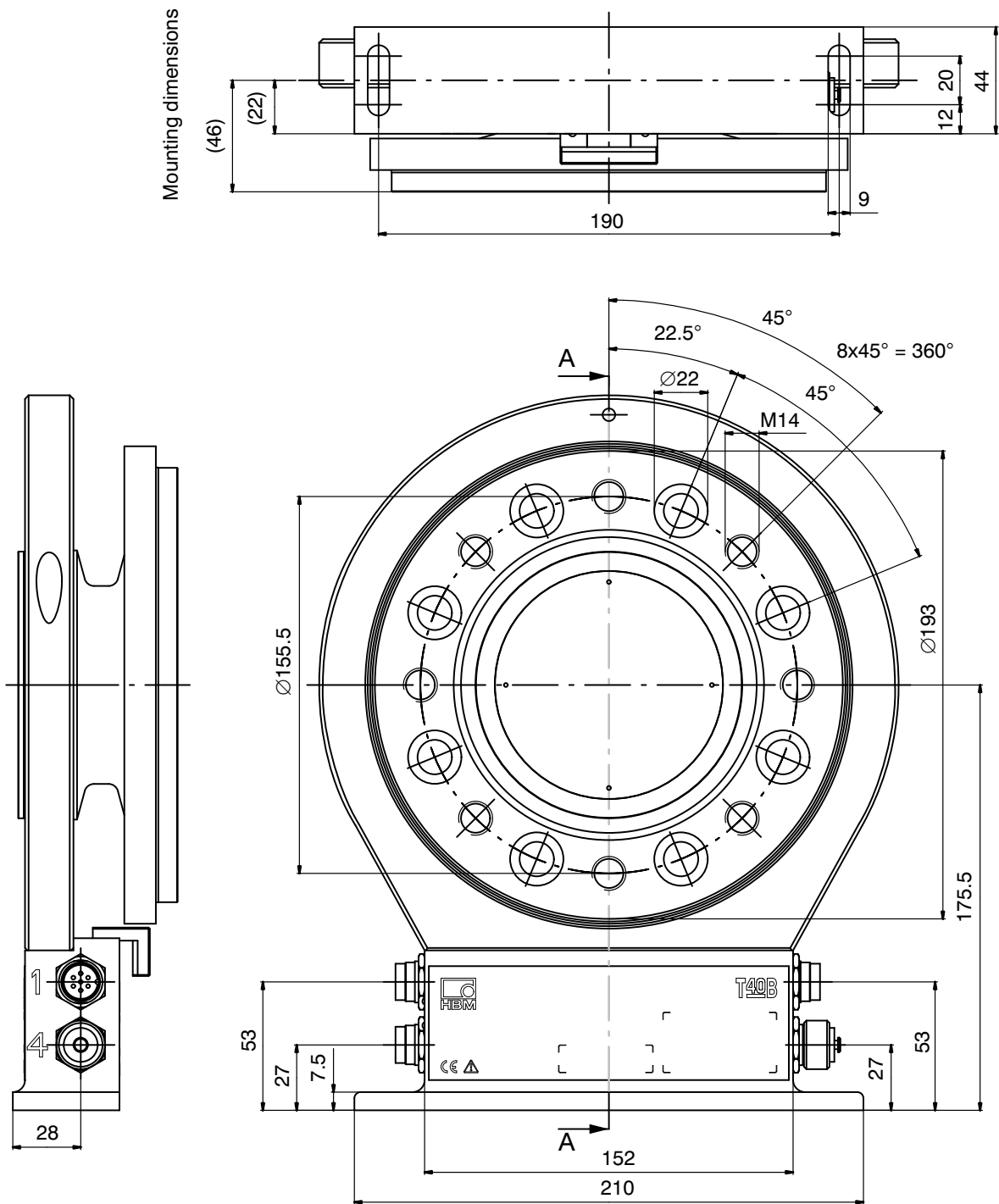

# Dimensions of T40B/5 kNm with rotational speed measurement, continued

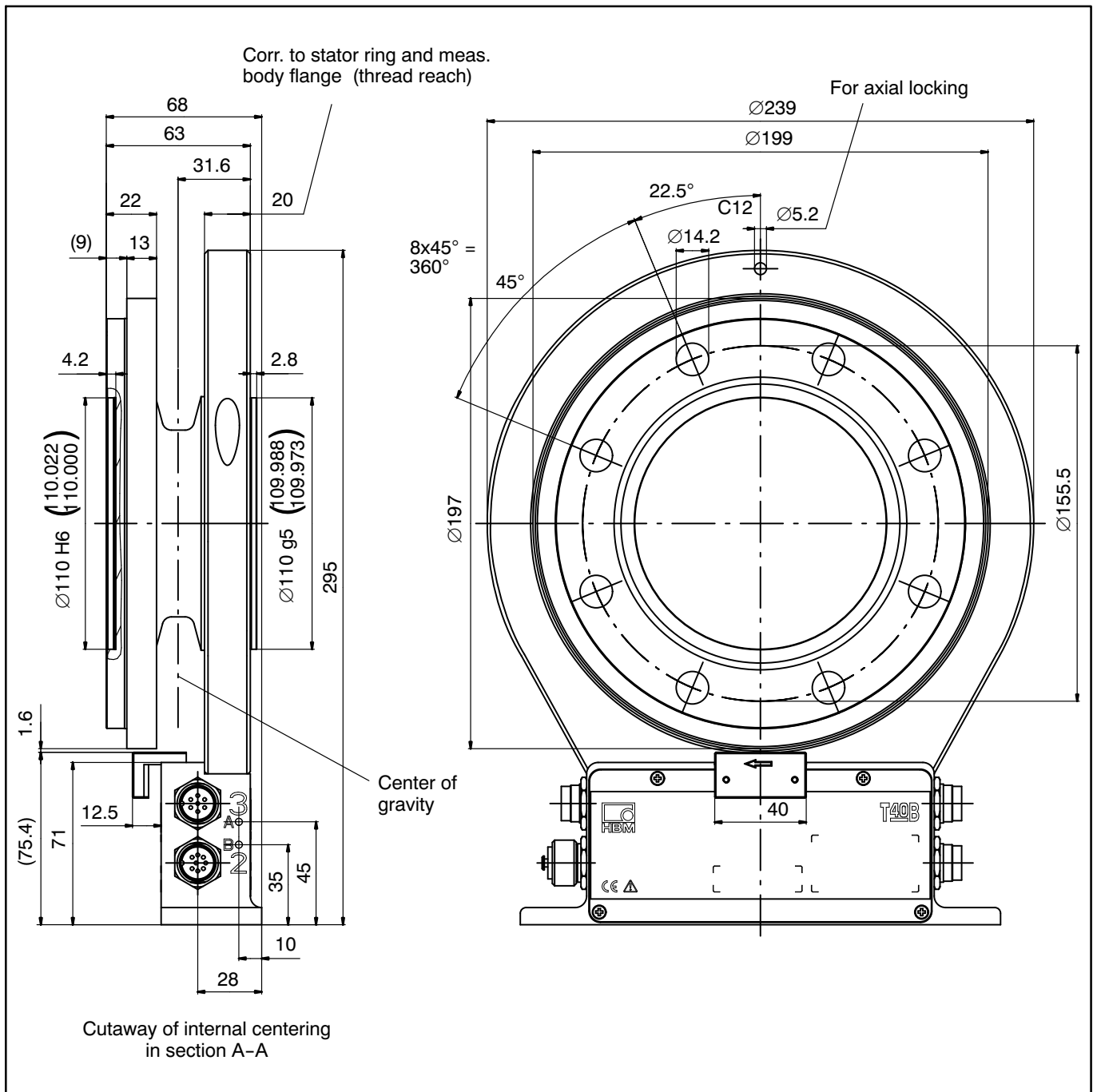

# Dimensions of T40B/10 kNm with rotational speed measurement

Dimensions in mm (1 mm = 0.03937 inches)

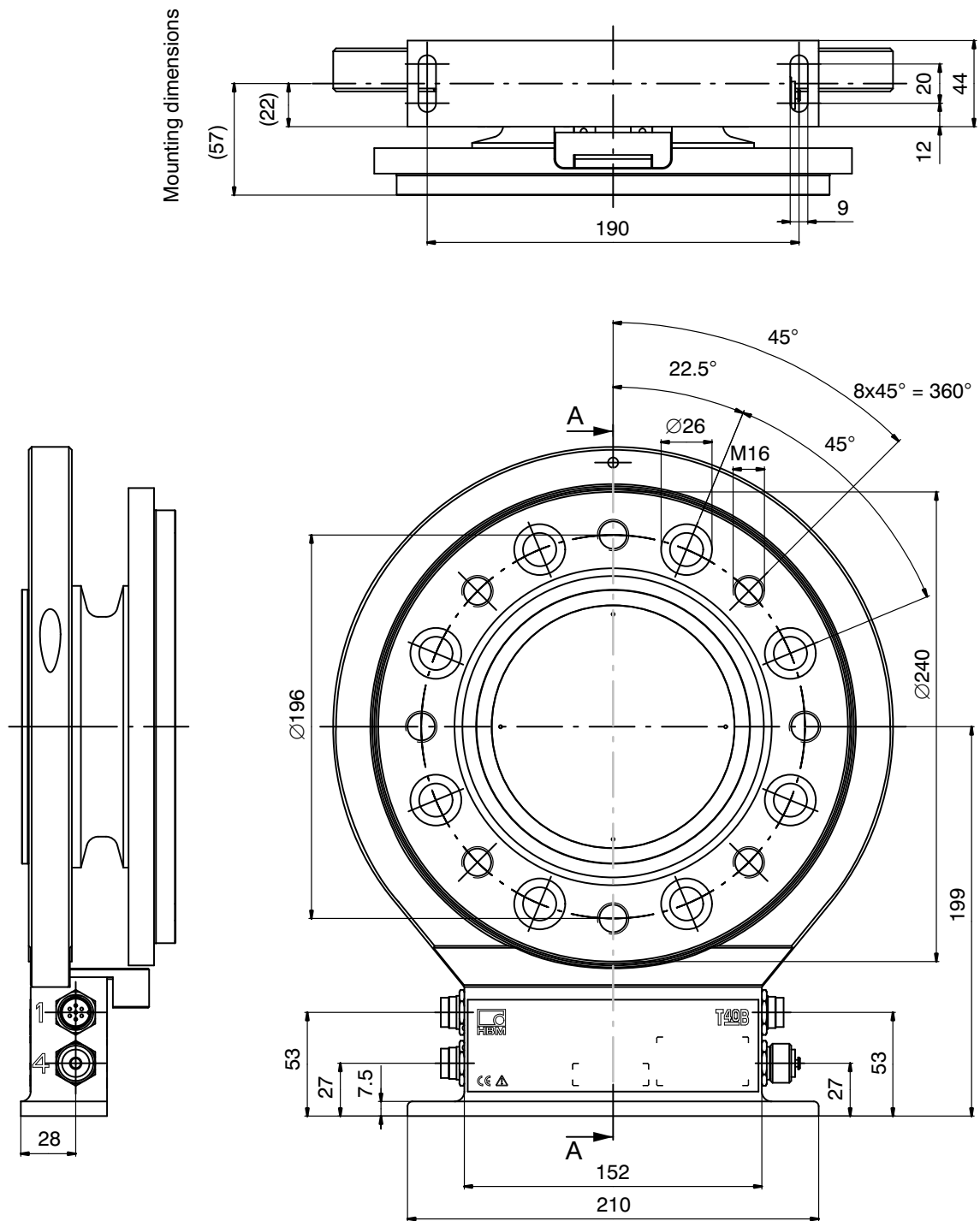

# Dimensions of T40B/10 kNm with rotational speed measurement, continued

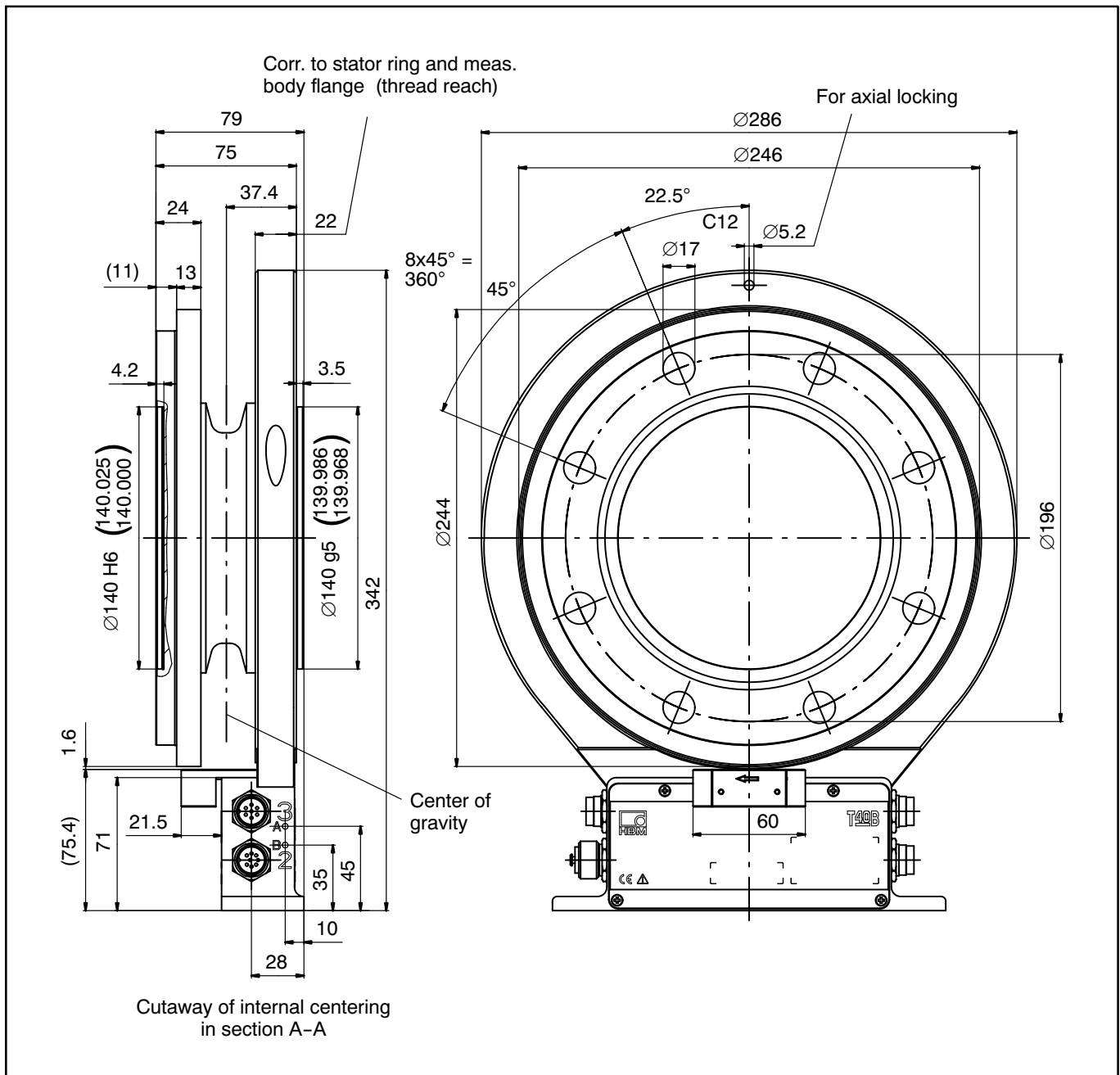

## Ordering numbers

Order no.		
<b>K-T40B</b>		[ only with Option 2 = MF / ST ]
<b>Code</b>	Option 1: Measuring range up to	
<b>200Q</b>	200 N·m	[ only with Option 2 = MF / RO ]
<b>500Q</b>	500 N·m	[ only with Option 2 = MF / RO ]
<b>001R</b>	1 kN·m	[ only with Option 2 = MF / RO ]
<b>002R</b>	2 kN·m	[ only with Option 2 = MF / RO ]
<b>003R</b>	3 kN·m	[ only with Option 2 = MF / RO ]
<b>005R</b>	5 kN·m	[ only with Option 2 = MF / RO ]
<b>010R</b>	10 kN·m	[ only with Option 2 = MF / RO ]
<b>Code</b>	Option 2: Component	
<b>MF</b>	Measurement flange, complete	
<b>RO</b>	Rotor	
<b>ST</b>	Stator	
<b>Code</b>	Option 3: Accuracy	
<b>S</b>	Standard	
<b>Code</b>	Option 4: Adjustment	
<b>M</b>	Metric (N·m)	
<b>Code</b>	Option 5: Electrical configuration	[ only with Option 2 = MF / ST ]
<b>SU2</b>	10 kHz $\pm$ 5 kHz and $\pm$ 10 V output signal, 18...30 V DC supply voltage	
<b>DU2</b>	60 kHz $\pm$ 30 kHz and $\pm$ 10 V output signal, 18...30 V DC supply voltage	
<b>HU2</b>	240 kHz $\pm$ 120 kHz and $\pm$ 10 V output signal, 18...30 V DC supply voltage	
<b>Code</b>	Option 6: Rotational speed measuring system	
<b>0</b>	Without rot. speed measuring system	
<b>1</b>	Magnetic rot. speed measuring system; 1024 pulses/revolution	
<b>Code</b>	Option 7: Customised modification	
<b>S</b>	No customer-specific modification	
<b>K-T40B-</b> <input type="text"/> <input type="text"/> <input type="text"/> <input type="text"/> - <input type="text"/> - <b>S</b> - <b>M</b> - <input type="text"/> <input type="text"/> <input type="text"/> <input type="text"/> - <input type="text"/> - <b>S</b> <span style="margin-left: 20px;">= PREFERENCE Types</span>		

## Accessories, to be ordered separately

Article	Order no.
<b>Connection cable, set</b>	
Torque connection cable, binder 423 – D-Sub 15P, 6 m	1-KAB149-6
Torque connection cable, binder 423 – free ends, 6 m	1-KAB153-6
Rotational speed connection cable, binder 423 – 8-pin free ends, 6 m	1-KAB154-6
Rotational speed connection cable, binder 423 – 8-pin D-Sub, free ends, 6 m	1-KAB163-6
TMC connection cable, binder 423 – 16-pin free ends, 6 m	1-KAB174-6
<b>Cable sockets</b>	
423G-7S, 7-pin (straight)	3-3101.0247
423W-7S, 7-pin (angle)	3-3312.0281
423G-8S, 8-pin (straight)	3-3312.0120
423W-8S, 8-pin (angle)	3-3312.0282
<b>Connection cable, by the meter (min. order quantity: 10 m, price per meter)</b>	
Kab8/00-2/2/2	4-3301.0071

Modifications reserved.

All product descriptions are for general information only. They are not to be understood as a guarantee of quality or durability and do not constitute any liability whatsoever.

**Hottinger Baldwin Messtechnik GmbH**

Im Tiefen See 45 · 64293 Darmstadt · Germany  
Tel. +49 6151 803-0 · Fax: +49 6151 803-9100  
Email: [info@hbm.com](mailto:info@hbm.com) · [www.hbm.com](http://www.hbm.com)

measure and predict with confidence

