

ROBA DS torsionally stiff shaft coupling

for the T40 torque flange

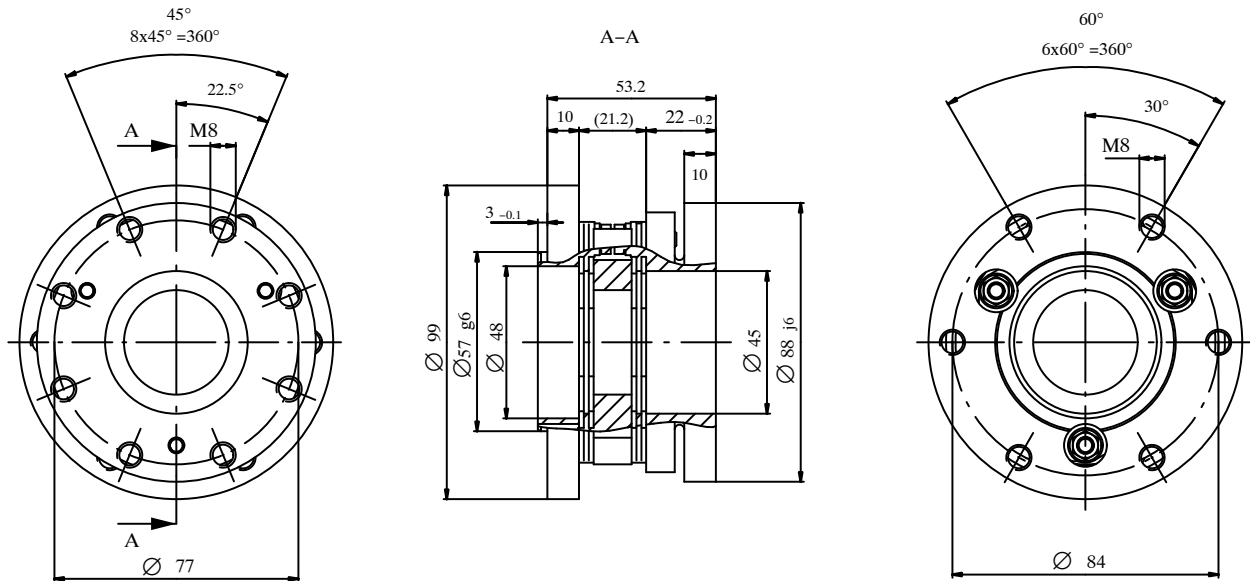

Mounting dimensions ROBA-DS for T40/200 N m



Specifications

HBM part no.: 1-4411.0110	Part of the T40, measuring range 200 N m		
Nominal (rated) torque	T_{KN}	200	N m
Limit torque	$T_{K max}$	400	N m
Oscillation bandwidth (torque) per DIN 50100 (peaktopeak)	T_{KW}	400	N m
Axial compliance ¹⁾	$\Delta K_a max$	0.8	mm
Radial compliance ¹⁾	$\Delta K_r max$	0.2	mm
Angular compliance ¹⁾	$\Delta K_W max$	1.4	deg (°)
Torsional spring rate ¹⁾	$C_T tot$	0.09×10^6	N m/rad
Maximum rotational speed (coupling)	n_{max}	15000	min ⁻¹
Mass moment of inertia	J	0.0017	kg m ²
Balance quality per ISO 1940		2.5	5000 min ⁻¹
Mass (coupling)	m	1.42	kg
Axial stiffness ¹⁾	c_a	290	N/mm
Radial stiffness	c_r	2105	N/mm
Angular stiffness ¹⁾	c_w	143	N m/rad

¹⁾ The specified values apply to the complete coupling

Mounting dimensions ROBA-DS for T40/500 N m – 1 kN m

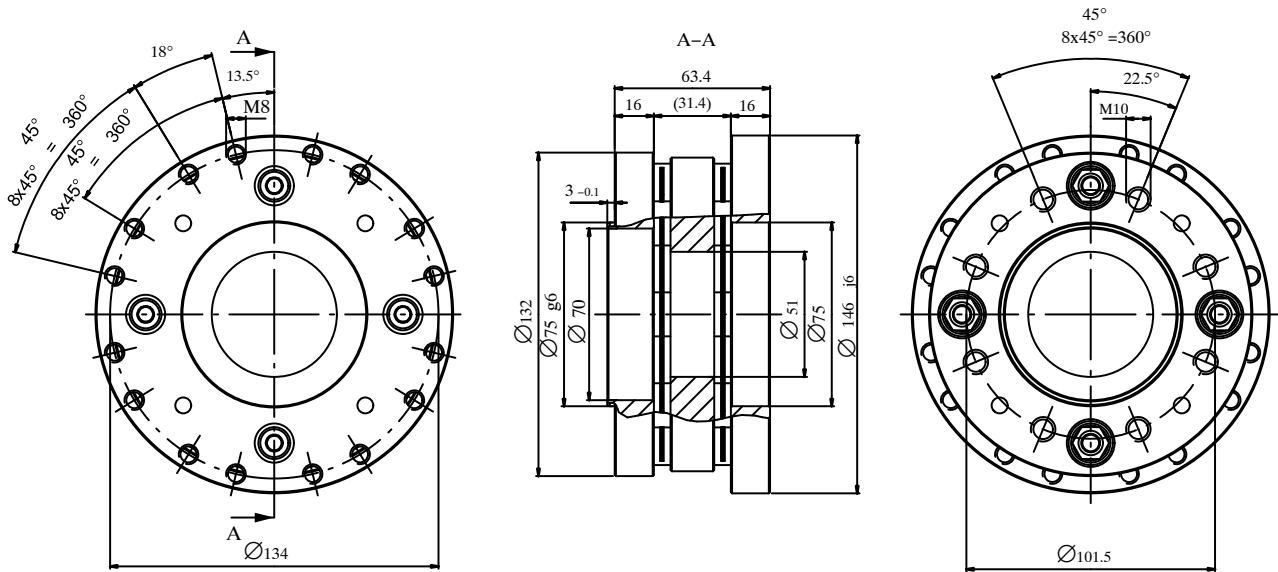

Specifications

HBM part no.: 1-4411.0111	Part of the T40, measuring range 500 N m – 1 kN m		
Nominal (rated) torque	T_{KN}	1000	N m
Limit torque	$T_{K \max}$	2000	N m
Oscillation bandwidth (torque) per DIN 50100 (peaktopeak)	T_{KW}	2000	N m
Axial compliance ¹⁾	$\Delta K_a \max$	1.1	mm
Radial compliance ¹⁾	$\Delta K_r \max$	0.25	mm
Angular compliance ¹⁾	$\Delta K_W \max$	1.2	deg ($^\circ$)
Torsional spring rate ¹⁾	$C_T \text{ tot}$	0.9×10^6	N m/rad
Maximum rotational speed (coupling)	n_{\max}	12000	min ⁻¹
Mass moment of inertia	J	0.0121	kg m ²
Balance quality per ISO 1940		2.5	5000 min ⁻¹
Mass (coupling)	m	4.25	kg
Axial stiffness ¹⁾	c_a	486	N/mm
Radial stiffness	c_r	7335	N/mm
Angular stiffness ¹⁾	c_w	1077	N m/rad

¹⁾ The specified values apply to the complete coupling

Mounting dimensions ROBA-DS for T40/2 kN m – 3 kN m

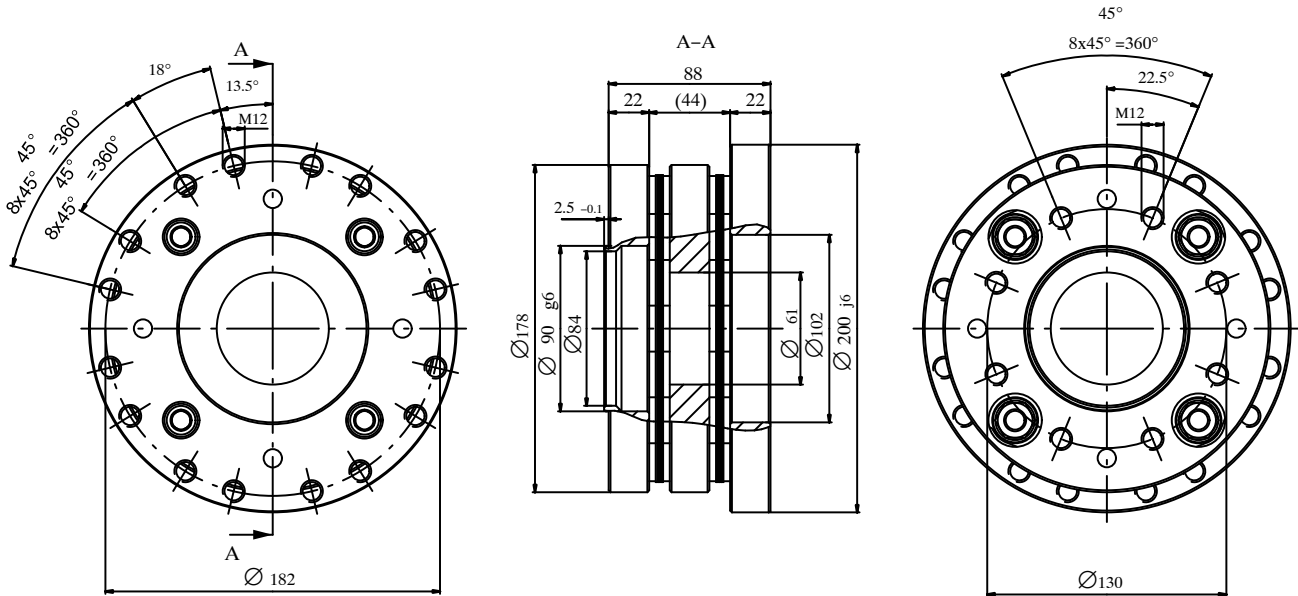

Specifications

HBM part no.: 1-4411.0112	Part of the T40, measuring range 2 kN m – 3 kN m		
Nominal (rated) torque	T_{KN}	3000	N m
Limit torque	$T_{K \max}$	4800	N m
Oscillation bandwidth (torque) per DIN 50100 (peaktopeak)	T_{KW}	4800	N m
Axial compliance ¹⁾	$\Delta K_a \max$	1.2	mm
Radial compliance ¹⁾	$\Delta K_r \max$	0.25	mm
Angular compliance ¹⁾	$\Delta K_W \max$	1	deg (°)
Torsional spring rate ¹⁾	$C_T \text{ tot}$	1.74×10^6	N m/rad
Maximum rotational speed (coupling)	n_{\max}	12000	min ⁻¹
Mass moment of inertia	J	0.0577	kg m ²
Balance quality per ISO 1940		2.5	5000 min ⁻¹
Mass (coupling)	m	11.17	kg
Axial stiffness ¹⁾	c_a	850	N/mm
Radial stiffness	c_r	14855	N/mm
Angular stiffness ¹⁾	c_w	3490	N m/rad

¹⁾ The specified values apply to the complete coupling

Mounting dimensions ROBA-DS for T40/5 kN m

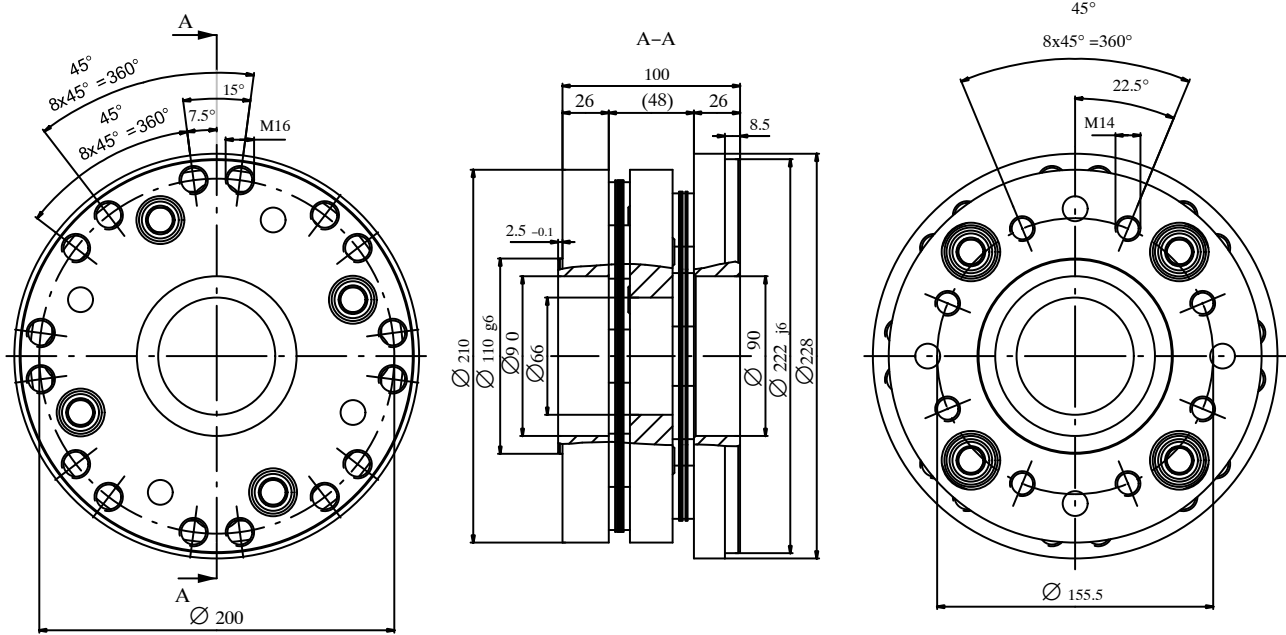

Specifications

HBM part no.: 1-4411.0113	Part of the T40, measuring range 5 kN m		
Nominal (rated) torque	T_{KN}	5000	N m
Limit torque	$T_{K \max}$	8000	N m
Oscillation bandwidth (torque) per DIN 50100 (peaktopeak)	T_{KW}	8000	N m
Axial compliance ¹⁾	$\Delta K_a \max$	1.4	mm
Radial compliance ¹⁾	$\Delta K_r \max$	0.35	mm
Angular compliance ¹⁾	$\Delta K_W \max$	1	deg ($^\circ$)
Torsional spring rate ¹⁾	$C_T \text{ tot}$	5.95×10^6	N m/rad
Maximum rotational speed (coupling)	n_{\max}	10000	min^{-1}
Mass moment of inertia	J	0.1223	kg m^2
Balance quality per ISO 1940		2.5	5000 min^{-1}
Mass (coupling)	m	18.57	kg
Axial stiffness ¹⁾	c_a	730	N/mm
Radial stiffness	c_r	15582	N/mm
Angular stiffness ¹⁾	c_w	5625	N m/rad

¹⁾ The specified values apply to the complete coupling

Mounting dimensions ROBA-DS for T40/10 kN m

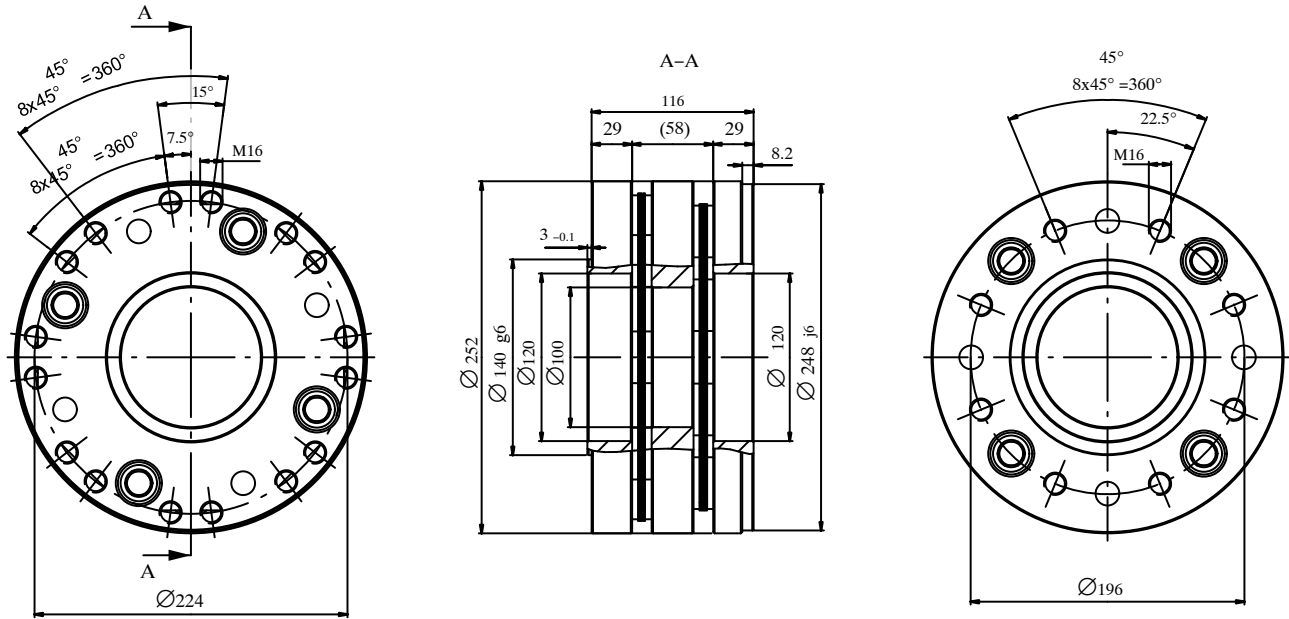

Specifications

HBM part no.: 1-4411.0114	Part of the T40, measuring range 10 kN m		
Nominal (rated) torque	T_{KN}	10000	N m
Limit torque	$T_{K \max}$	16000	N m
Oscillation bandwidth (torque) per DIN 50100 (peaktopeak)	T_{KW}	16000	N m
Axial compliance ¹⁾	$\Delta K_a \max$	1.6	mm
Radial compliance ¹⁾	$\Delta K_r \max$	0.4	mm
Angular compliance ¹⁾	$\Delta K_W \max$	1	deg (°)
Torsional spring rate ¹⁾	$C_{T \text{ tot}}$	10.3×10^6	N m/rad
Maximum rotational speed (coupling)	n_{\max}	10000	min ⁻¹
Mass moment of inertia	J	0.2635	kg m ²
Balance quality per ISO 1940		2.5	5000 min ⁻¹
Mass (coupling)	m	28.08	kg
Axial stiffness ¹⁾	c_a	1490	N/mm
Radial stiffness	c_r	18424	N/mm
Angular stiffness ¹⁾	c_w	9290	N m/rad

¹⁾ The specified values apply to the complete coupling

Permissible displacement of shaft ends

If several types of displacement occur simultaneously, they are mutually influential, that is, the permissible displacement values are interdependent. The sum of the actual displacements as a percentage of the maximum value, must not exceed 100%, as shown in the example.

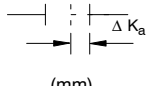
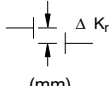
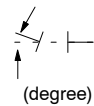
Axial misalignment of coupling half members 	Radial misalignment of coupling half members 	Angular misalignment, ΔKw 
---	--	---

Example: 1-4111.0111 ROBA-DS 500 Nm

An occurring axial misalignment of $\Delta K_a = 0.44$ mm corresponds to 40% of the permissible maximum value $\Delta K_a = 1.1$ mm. An occurring angular misalignment of $\Delta K_w = 0.36^\circ$ corresponds to 30% of the permissible maximum value $\Delta K_w = 1.2^\circ$.

Still permissible as a result, is a radial misalignment of $\Delta K_r = 0.25$ mm, that is, a maximum of 0.075 mm is permissible.

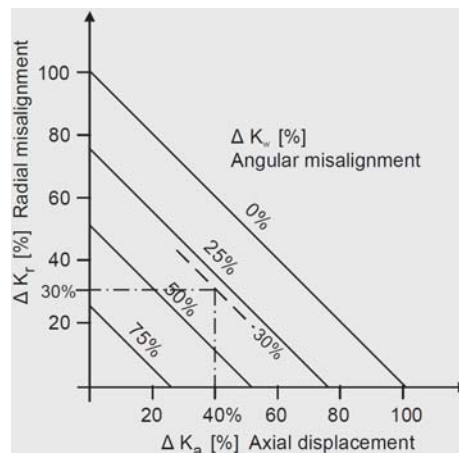

Valid standards: Coupling characteristics per DIN 740, Part 2, Section 2.1. Stress values per DIN 740, Part 2, Sections 2.2 and 3 (coupling design for special applications). Coupling dynamically balanced as per ISO 1940 (at 5000 m⁻¹). Finish: zinc phosphate coating.

General installation notes

The coupling disc packs must not be overstretched beyond the specified permissible compliances!

Mounting position

The ROBA-DS shaft coupling can be operated with the T40 torque flange in any mounting position (horizontal or vertical). In the case of vertical operation, make sure that the masses of the test bench do not cause the permissible longitudinal force to be exceeded.

Installation

Caution: The coupling must first be fitted to the torque transducer, before the combination is installed in the shaft train. Only the screws specified in Table 1 must be used.

Measuring range	Number of screws	Socket head cap screw DIN EN ISO 4762	Tightening torque
in N m		bk / oiled / $\mu_{tot} = 0.125$	in N m
200	6	M8x20 -10.9	34
500	8	M10x30 -10.9	67
1k		M12x40 -12.9	135
2k		M14x45 -12.9	215
3k		M16x50 -12.9	340
5k			
10k			

Table 1: Permissible screw connections for coupling-T40 torque flange

- Clean the flange and degrease it with a solvent (such as acetone).
- First of all, tighten the screws at half tightening torque "crosswise", in a diagonally opposite sequence. Then, "crosswise" again, tighten them at full torque (see Table 1 for the tightening torques).
- Now mount the torque flange/coupling combination in the shaft train. First of all, tighten the screws at half tightening torque "crosswise", in a diagonally opposite sequence. Then, "crosswise" again, tighten them at full torque (see Table 2 for the tightening torques).

Caution: The connecting screws provided by the customer must not impair the function of the couplings (see maximum thread reach, Table 2).

Measuring range	Number of screws	Socket head cap screw DIN EN ISO 4762	Tightening torque	Maximum thread reach
in N m		bk / oiled / $\mu_{tot} = 0.125$	in N m	in mm
200	8	M8 -10.9	34	10
500	16			M12 -10.9
1k		115	22	
2k				
3k		340	29	
5k				
10k			M16 -12.9	

Table 2: Permissible screw connections for coupling-test bench (provided by customer)

© Hottinger Baldwin Messtechnik GmbH. Modifications reserved. All details describe our products in general form only. They are not to be understood as a guarantee of quality or durability and do not constitute any liability whatsoever.

Hottinger Baldwin Messtechnik GmbH

Im Tiefen See 45 · 64293 Darmstadt · Germany
Tel. +49 6151 803-0 · Fax: +49 6151 803-9100
Email: info@hbm.com · www.hbm.com

measure and predict with confidence

