

BSD MODULFLEX[®] Torsionally Rigid Coupling

for T12 digital torque transducers

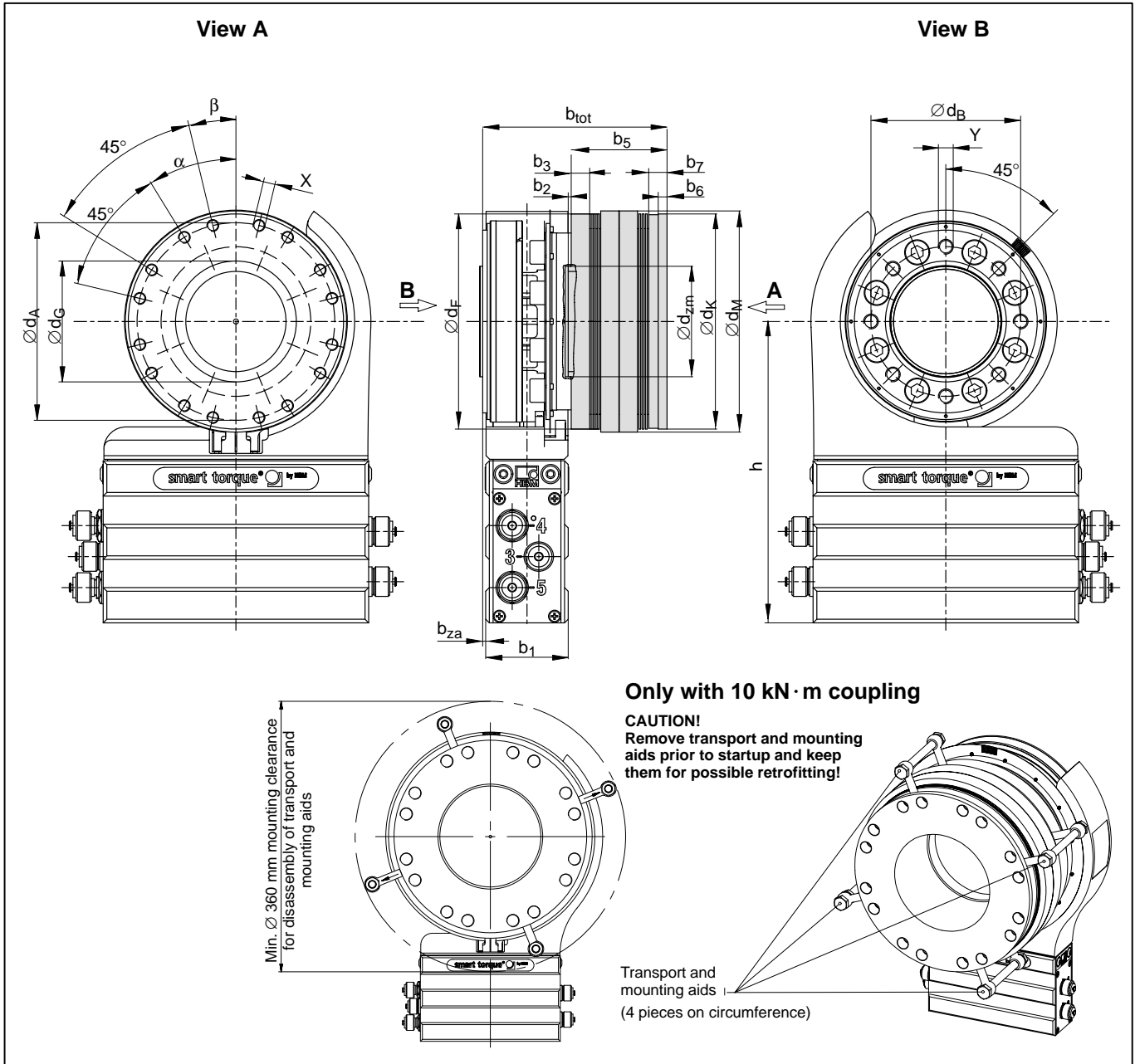

Dimensions

Measuring range (N·m)	Coupling (mm)														Torque transducer (mm)					
	δ_{DF}	δ_{DK}	δ_{DA}	δ_{ZM}	δ_M	δ_G	b_{TOT}	b_3	b_5	b_6	b_7	X	α^1	β^1	h	δ_B	b_1	b_2	b_{ZA}	Y
500 ... 1 k	146	146 _{j6}	134	75 _{g6}	152	82	125	12.5	65	6	12.5	M8	31.5	13.5	204.5	101.5	56	2	2	M10
2 k ... 3 k	200	200 _{j6}	182	90 _{g6}	209	102	152	17	88	8.5	17	M12	31.5	13.5	222.5	130		2.5	3	M12
5 k	222	222 _{j6}	200	110 _{g6}	231	118	184	19.1	100	8.5	19.1	M16	30	15	239.5	155.5		2	3	M14
10 k	248	248 _{j6}	224	140 _{g6}	262	135	208	22.8	116	8.2	22.8	M16	30	15	263.5	196		2	3	M16

¹⁾ In Degree

Technical Data

Measuring range T12 (N·m)	Articel number	Nominal (rated) torque (N·m)	Maximum rotation speed n_{max} (rpm)	Limit torque (N·m)	Oscillation bandwidth (torque) DIN 50100 (peak-to-peak) (N·m)	Weight of the coupling (kg)	Mass moment of inertia J (without torque transducer) (kg·m ²)	Rotational rigidity C_T tot (without torque transducer) (kN·m/rad)
500 ... 1 k	1-4411.0105	1000	12000	2000	1700	5.2	0.018	690
2 k ... 3 k	1-4411.0106	3000	12000	4800	4500	14	0.088	1940
5 k	1-4411.0108	5000	10000	8000	6400	18.8	0.149	2505
10 k	1-4411.0109	10000	10000	16000	11000	28.7	0.305	3595

Permitted shaft-end misalignment

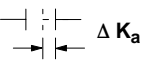
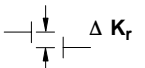
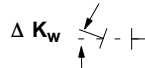
Measuring range (N·m)	Maximum axial misalignment  (mm)	Maximum radial misalignment  (mm)	Maximum angular misalignment  (degree)
500 ... 1 k	± 3	0.42	0.75
2 k ... 3 k	± 4	0.58	0.75
5 k	± 4.2	0.65	1.5
10 k	± 5	0.76	1.5

The given misalignments are maximum values for only one directions of misalignment. If operating conditions require several misalignments simultaneously, the values will be reduced according to the shown graph and formula.

$$\Delta K_r = x \cdot \tan \Delta K_w$$

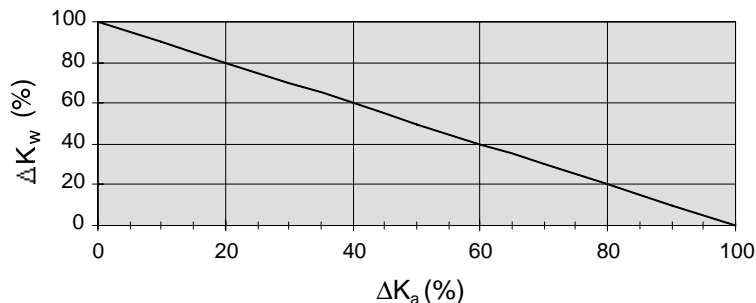

Applicable norms and standards: Coupling characteristics in accordance with DIN 740, Part 2, Section 2.1.
Loading quantities in accordance with DIN 740, Part 2, Sections 2.2 and 3 (Coupling design for special applications).

Diagrams axial, radial and angular displacement

Measuring range 500 N·m ... 1 kN·m

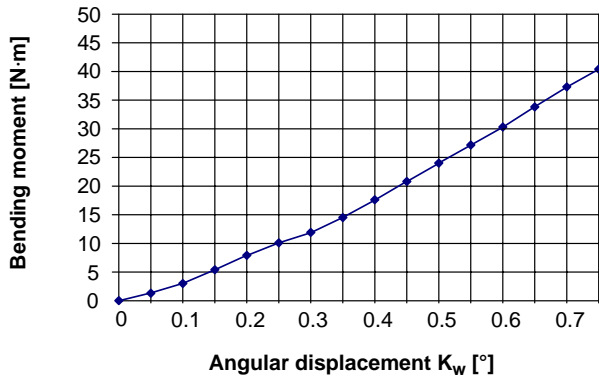
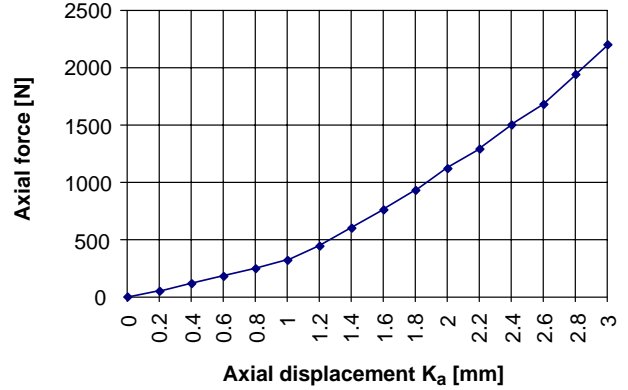
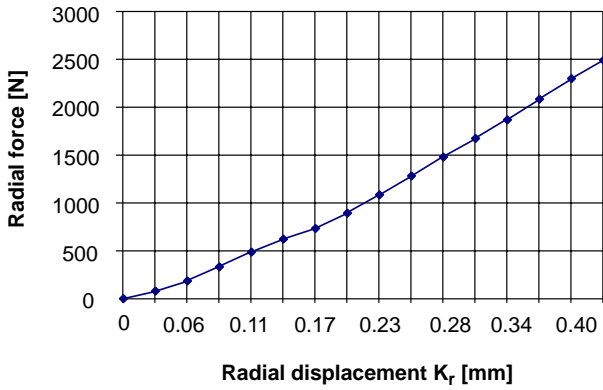

Measuring range 2 kN·m ... 3 kN·m

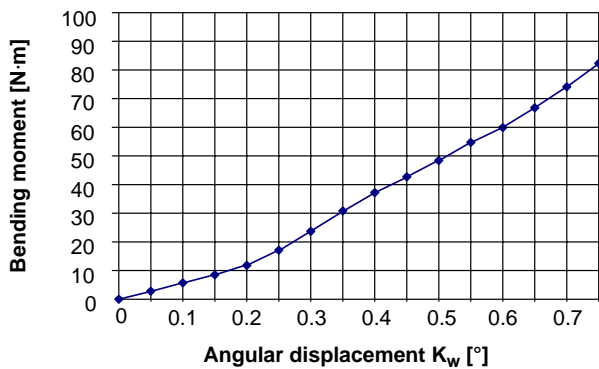
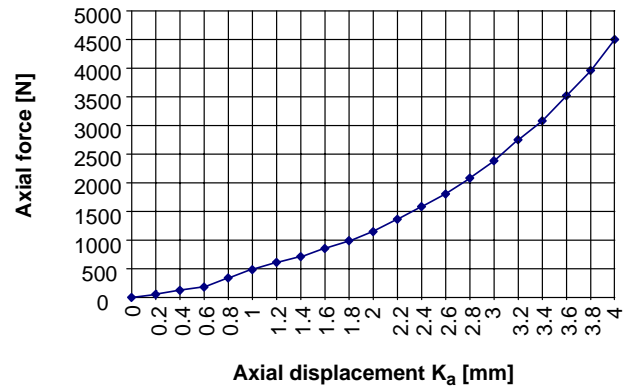
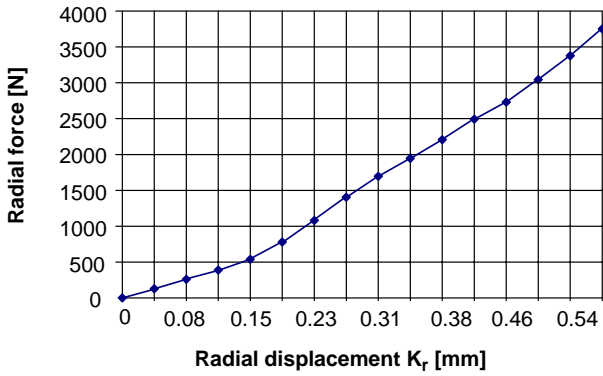

Diagrams axial, radial and angular displacement

Measuring range 5 kN·m

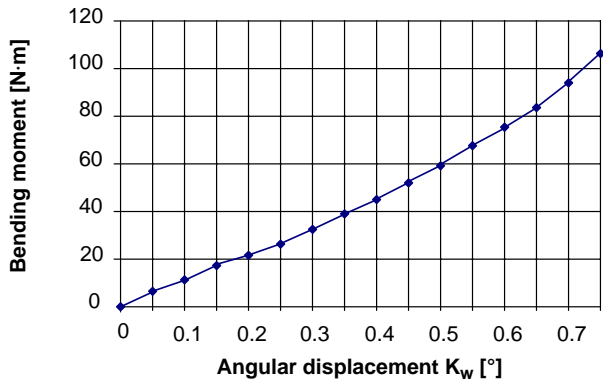
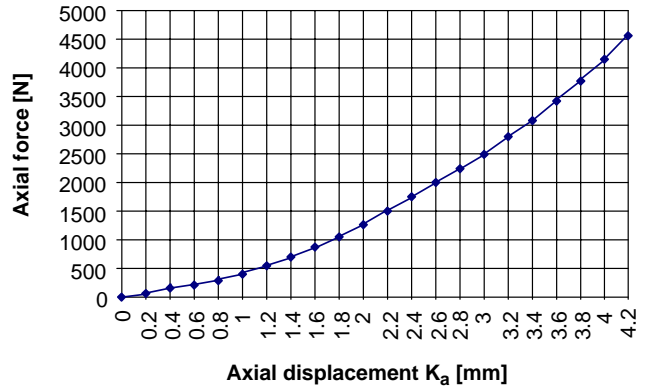
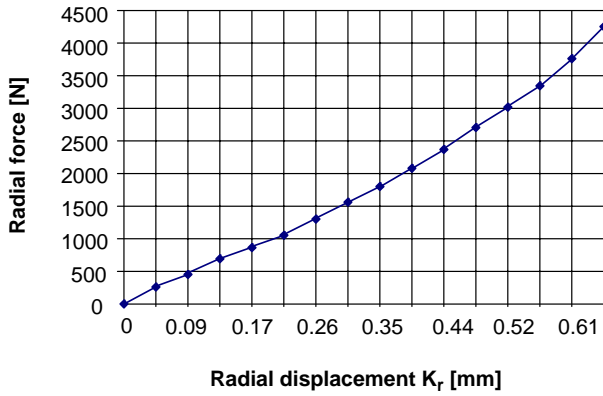

Measuring range 10 kN·m

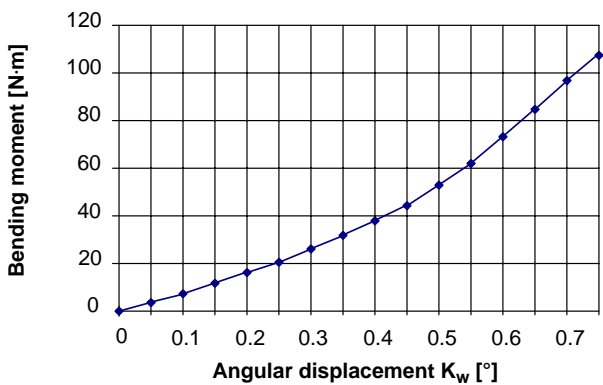
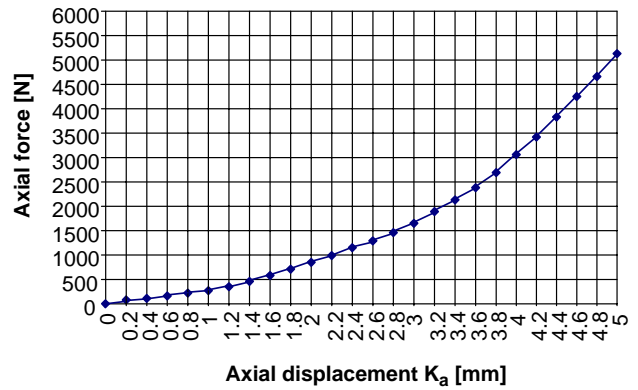
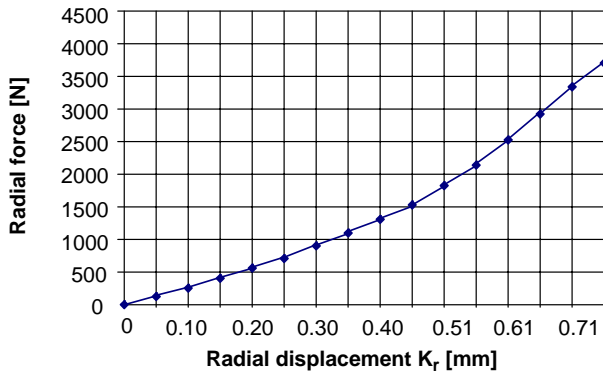

General notes on installation

The laminated packaging of the couplings must not be overstressed beyond the specified permitted compliance values!

Installation position

The BSD-MODULFLEX coupling can be operated in any installation position (horizontally or vertically) with the T12 digital torque transducer. During vertical operation, ensure that the permitted axial force is not exceeded due to the masses present in the test rig.

Delivery state

If the T12 has been ordered complete with coupling (option 8, code Y; see data sheet T12), the coupling will be fitted to the torque transducer at HBM. Couplings and the digital torque transducer are individually balanced in accordance with DIN ISO1940 quality level G 2.5. The combined unit will not be re-balanced after mounting.

Installation



CAUTION

Remove the transport and mounting aids for size 10 kN·m have to be removed prior to startup and keep them for possible retrofitting!

- For perfect function it is essential to conform to reference dimension b_{tot} !
- If the coupling and torque transducer are separate when delivered, you must first fit the coupling to the digital torque transducer before installing the combined unit in the shaft run. Use only screws of the type specified in Table 1!
- Clean the flange and degrease it with a solvent (e.g. acetone).
- First of all tighten the screws “crosswise” with half tightening torque. Then tighten them “crosswise” again with full tightening torque (for tightening torque see Table 1).
- Then install the combined unit in the shaft run. First of all tighten the screws “crosswise” with half tightening torque. Then tighten them “crosswise” again with full tightening torque (for tightening torque see Table 2).

Caution: The connecting screws on the user side must not impede the function of the couplings (see maximum screwed-in depth, Table 2).

After installation, please check that the couplings are not deformed.

Measuring range (N·m)	Number of screws	Fillister-head screw DIN EN ISO 4762 bk/oiled/ $\mu_{tot}=0.125$	Prescribed tightening torque M_d (N·m)	Weight of screw (kg/piece)
500 ... 1k	8	M10 x 30 – 10.9	67	0.02680
2 k ... 3 k		M12 x 35 – 12.9	135	0.04290
5 k		M14 x 45 – 12.9	215	0.07075
10 k		M16 x 50 – 12.9	340	0.11115

Table 1: Screws for connecting coupling to T12 digital torque transducer (view B – included in the scope of supply)

Measuring range (N·m)	Number of screws	Fastening screws strength class 10.9	Prescribed tightening torque M_d (N·m)	Maximum screwed-in depth (mm)
500 ... 1k	16	M8	34	12.5
2 k ... 3 k		M12	115	17
5 k		M16	215	19.1
10 k		M16	340	22.8

Table 2: Fastening screws for coupling and test rig (view A)

More notes on fitting can be found in the mounting instructions for the T12.

Modifications reserved.

All details describe our products in general form only. They are not to be understood as express warranty and do not constitute any liability whatsoever.

B1958-4.0 en

Hottinger Baldwin Messtechnik GmbH

Im Tiefen See 45, D-64293 Darmstadt, Germany

Tel.: +49 6151 803-0 Fax: +49 6151 803 9100

Email: support@hbm.com Internet: www.hbm.com



measurement with confidence