

T10FS

Torque Flange



Special features

- Nominal (rated) torques: 100 N·m, 200 N·m, 500 N·m, 1 kN·m, 2 kN·m, 3 kN·m, 5 kN·m, 10 kN·m
- Nominal speed from 12,000 rpm to 24,000 rpm
- Low rotor weights
- Small mass moments of inertia
- Small outside diameters
- Non-contacting
- Option: integrated magnetic or optical speed measuring system

Installation example

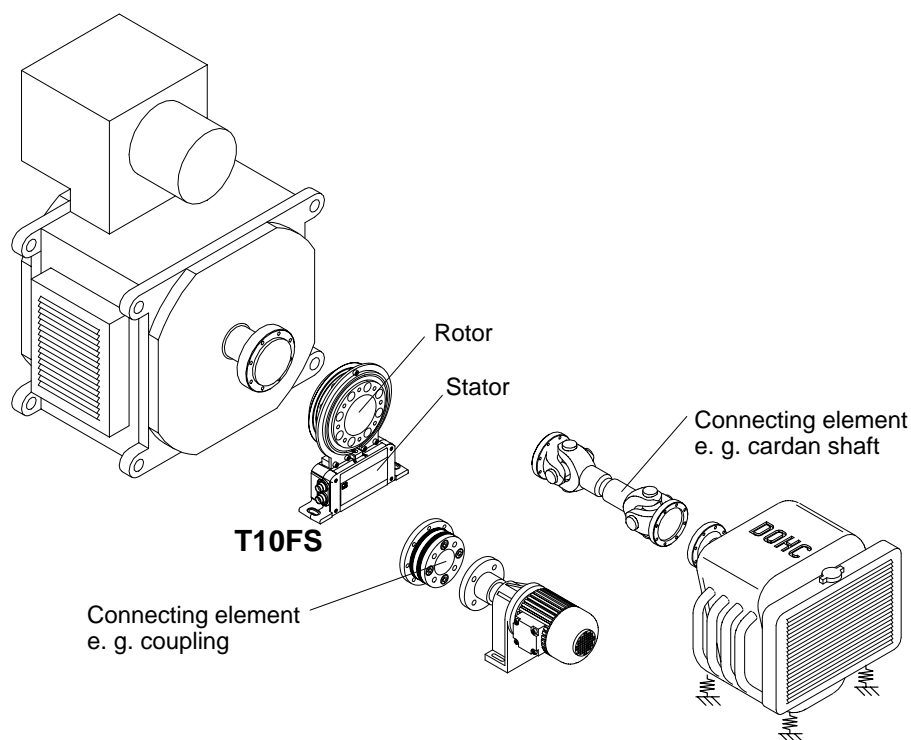

Specifications

Type	T10FS								
Accuracy class	0.05								
Torque measuring system									
Nominal (rated) torque M_{nom} for reference only	N·m	100	200	500	1 k	2 k	3 k	5 k	10 k
	ft·lb	75	150	375	750	1,500	2,250	3,750	7,500
Nominal sensitivity (range between torque = zero and nominal (rated) torque)									
Frequency output	kHz	5							
Voltage output	V	10							
Characteristic tolerance (deviation of the actual output quantity at M_{nom} from the nominal sensitivity)									
Frequency output	%	± 0.1							
Voltage output	%	± 0.2							
Output signal at torque = zero									
Frequency output	kHz	10							
Voltage output	V	0							
Nominal output signal									
Frequency output with positive nominal (rated) torque	kHz	15 (5 V symmetric ¹)/12 V asymmetric ²)							
Frequency output with negative nominal (rated) torque	kHz	5 (5 V symmetric ¹)/12 V asymmetric ²)							
Voltage output with positive nominal (rated) torque	V	+10							
Voltage output with negative nominal (rated) torque	V	-10							
Load resistance									
Frequency output	kΩ	≥ 2							
Voltage output	kΩ	≥ 5							
Long-term drift over 48 h									
Voltage output	mV	≤ ± 3							
Measurement frequency range									
Voltage output	Hz	0 ... 1000 (-3 dB)							
Group delay time									
Frequency output	ms	0.15							
Voltage output	ms	0.9							
Residual ripple									
Voltage output	mV	40 (peak-to-peak)							
Temperature influence per 10 K in the nominal temperature range on the output signal, related to the actual value of signal span									
Frequency output	%	< ± 0.05							
Voltage output	%	< ± 0.15							
on the zero signal, related to the nom. sensitivity									
Frequency output	%	< ± 0.05 (< ± 0.03 optional)							
Voltage output	%	< ± 0.15 (< ± 0.13 optional)							
Max. modulation range³⁾									
Frequency output	kHz	4...16							
Voltage output	V	-10.5...+10.5 (typ. ± 11)							
Power supply (version KF1)									
Excitation voltage (square wave)	V	54 ± 5% (peak-to-peak)							
Release of calibration signal	V	80 ± 5 %							
Frequency	kHz	approx. 14							
Max. current consumption	A	1 (peak-to-peak)							
Preamplifier excitation voltage	V	0/0/+15							
Preamplifier, max. current consumption	mA	0/0/+25							
Power supply (version SF1/SU2)									
Nominal supply voltage (protective low voltage)	V (DC)	18 ... 30; asymmetric							
Current consumption in measuring mode	A	< 0.9							
Current consumption in start-up mode	A	< 2							
Nominal (rated) power consumption	W	< 12							

1) RS 422 complementary signals; factory settings version SF1/SU2

2) Factory settings version KF1 (no switching possible)

3) Output signal range with a repeatable interrelationship between torque and output signal.

Specifications (Continued)

Nominal (rated) torque M_{nom} for reference only	N·m	100	200	500	1 k	2 k	3 k	5 k	10 k
	ft·lb	75	150	375	750	1,500	2,250	3,750	7,500
Linearity deviation including hysteresis, related to the nominal sensitivity									
Frequency output	%	< ±0.05 (< ±0.03 optional)							
Voltage output	%	< ±0.07 (< ±0.05 optional)							
Rel. standard deviation of the reproducibility according to DIN 1319, by reference to variation of the output signal									
Frequency output	%	< ±0.03		< ±0.02					
Voltage output	%	< ±0.03							
Calibration signal		approx. 50 % of M_{nom} ; value given to the identification plate							
Tolerance of calibration signal related to M_{nom}	%	< ±0.05							
Magnetic speed measuring system									
Speed measuring system		magnetic by MR (Magneto-Resistive)-Sensor and magnetized plastic ring in stainless steel ring. Multiplication by realtime evaluation method.							
Magnetic poles	Number	120	144	180					
Pulse tolerance									
with evaluation factor 1 per pole	degree	< 0.1							
with factory default for evaluation factor	degree	< 0.2 (typ. < 0.1)							
Pulses per revolution									
Possible settings ⁴⁾ (evaluation factor per pole)	Number	120 (1); 480 (4); 600 (5); 960 (8); 1200 (10)	144 (1); 576 (4); 720 (5); 1152 (8); 1440 (10)	180 (1); 720 (4); 900 (5); 1440 (8); 1800 (10)					
Factory setting	Number	600 (5)		720 (5) ⁵⁾			720 (4)		
Possible settings with output pulse division ⁴⁾	Number	10 ... 1200		12 ... 1440			15 ... 1800		
Output signal	V	⁵⁾ symmetric 2 square wave signals approx. 90° phase shifted							
Max. output frequency	kHz	250							
Minimum speed for sufficient pulse stability	rpm	0							
Group delay time	µs	< 5 (typ. 1.3)							
Hysteresis of reversing the direction of rotation⁷⁾ with relative vibrations between rotor and stator									
Torsional rotor vibrations	degree	< approx. 1							
Radial stator vibrations	mm	< approx. 1							
Load resistance	kΩ	≥2 (Maintain termination resistors acc. to RS-422)							
Magnetic load limits	kΩ								
Residual flux density	mT	>100							
Coercive field strength	kA/m	>100							
Permissible magnetic field strength for signal deviations of 0.1 degree per pole	kA/m	<0.1							
Nominal (rated) clearance (sensor-pole ring)	mm	1.0						1.2	
Working distance range	mm	0.3 ... 1.8						0.3 ... 2.2	
Maximum permissible radial displacement between rotor and stator	mm	See working distance range of the magnetic system; can be adjusted by 1.5 mm at the sensor head							

4) When adjusting higher output pulse factors, take into account the maximum permissible output frequency of 250 kHz.

5) Max. permissible rotational speed for speed measurement: 20,500 rpm. At higher rotational speeds, smaller output pulses must be adjusted.

6) RS422 complementary signals

7) Can be switched off

Specifications (Continued)

Nominal (rated) torque M_{nom} for reference only	N·m	100	200	500	1 k	2 k	3 k	5 k	10 k
	ft·lb	75	150	375	750	1,500	2,250	3,750	7,500
Optical speed measuring system									
Speed measuring system	optical, by means of infrared light and metallic slotted disc								
Mechanical increments	Number	360						720	
Positional tolerance of the increments	mm	± 0.05							
Tolerance of the slot width	mm	± 0.05							
Pulses per rotation (electrically adjustable)	Number	360 ^{*)} ; 180; 90; 60; 30; 15						720; 360 ^{*)} ; 180; 90; 60; 30; 15	
Output signal	V	5 ⁸⁾ symmetric; 2 square wave signals approx. 90° phase shifted							
Minimum speed for sufficient pulse stability	rpm	2							
Group delay time	µs	< 5 (typ. 2.2)							
Hysteresis of reversing the direction of rotation⁹⁾ with relative vibrations between rotor and stator									
Torsional rotor vibrations	degree	< approx. 2							
Radial stator vibrations	mm	< approx. 2							
Load resistance	kΩ	≥ 2 (Maintain termination resistors acc. to RS-422)							
Permitted degree of soiling , in the optical path of the sensor fork (lenses, slotted disc)	%	< 50							
Measuring system: reference pulse									
Measuring system	magnetic by magnetic-field dependent resistor and magnet, synchronized with rising ^{*)} or falling edge of the optical speed measuring system's 0° output signal								
Output signal	V	5 symmetric							
Pulse width		0.5 degrees with 360 speed pulses/rev. (factory settings)							
Pulses per revolution		1							
Minimum speed for sufficient pulse stability	rpm	2							
Group delay time	µs	< 5 (typ. 2.2)							
Additional phase error with									
< 20 rpm	degree	typ. < 0.1; leading							
> 20 rpm	degree	negligible							
Repeatability with 360 speed pulses/rev.	degree	typ. < ± 0.04 (ideal mounting, non-vibrating operation)							
General data									
EMC									
EME (Emission according to EN61326-1, table 4) RFI field strength	-	Class B							
Immunity from interference (EN61326-1, table A.1)									
Electromagnetic field AM	V/m	10							
Magnetic field	A/m	30							
ESD									
Contact discharge	kV	4							
Air discharge	kV	8							
Burst	kV	1							
Surge	kV	1							
Line-conducted disturbance (AM)	V	3							
Degree of protection according to EN 60 529		IP 54							
Weight , approx. Rotor	kg	1.9	1.9	2.4	2.4	4.9	4.9	8.3	14.6
Stator	kg	1.2	1.2	1.2	1.2	1.3	1.3	1.3	1.3
Reference temperature	°C [°F]	+23 [73.4]							
Nominal temperature range	°C [°F]	+10...+60 [+50...+140]							
Service temperature range	°C [°F]	-10...+60 [+14...+140]							
Storage temperature range	°C [°F]	-20...+70 [-4...+158]							

^{*)} Factory setting

⁸⁾ RS 422 complementary signals

⁹⁾ Can be switched off

Specifications (Continued)

Nominal (rated) torque M_{nom} for reference only	N-m	100	200	500	1 k	2 k	3 k	5 k	10 k	
	ft-lb	75	150	375	750	1,500	2,250	3,750	7,500	
Impact resistance, test severity level to IEC 68; part 2-27; IEC 68-2-27-1987										
Number of impacts	n	1000								
Duration	ms	3								
Acceleration (half-sine)	m/s ²	650								
Vibration resistance, test severity level to IEC 68, part 2-6; IEC 68-2-6-1982										
Frequency range	Hz	5...65								
Duration	h	1.5								
Acceleration (amplitude)	m/s ²	50								
Nominal speed	rpm	15,000	12,000				10,000	8,000		
Nominal speed optional	rpm	24,000	22,000		18,000		14,000	12,000		
Load limits ¹⁰⁾										
Limit torque, related to M_{nom}	%	400	200				160			
Breaking torque, related to M_{nom}	%	> 800	> 400				> 320			
Axial limit force	kN	5	10	16	19	39	42	80	120	
Lateral limit force	kN	1	2	4	5	9	10	12	18	
Bending limit moment	N-m	50	100	200	220	560	600	800	1,200	
Oscillation bandwidth according to DIN 50100 (peak-to-peak)^{*)}	N-m	400	400	1000	2,000	4,000	4,800	8,000	16,000	
Mechanical values										
Torsional stiffness c_T	kN-m/rad	270	270	540	900	2,300	2,600	4,600	7,900	
Torsion angle at M_{nom}	degree	0.022	0.043	0.055	0.066	0.049	0.066	0.06	0.07	
Axial stiffness c_a	kN/mm	800	800	740	760	950	1,000	950	1,600	
Radial stiffness c_r	kN/mm	290	290	550	810	1,300	1,500	1,650	2,450	
Stiffness with bending moment about a radial axis c_b	kN-m/degree	7	7	11.5	12	21.7	22.4	43	74	
Maximum excursion at axial limit force	mm	< 0.02		< 0.03		< 0.05		< 0.1		
Additional max. concentricity error at lateral limit force	mm	< 0.02								
Additional plane-parallel deviation at bending limit moment	mm	< 0.03		< 0.05		< 0.07		< 0.07		
Balance quality-level to DIN ISO 1940		G 2.5								
Max. limits for relative shaft vibration (peak-to-peak)¹¹⁾	μm	$s_{max} = \frac{4500}{\sqrt{n}}$ (n in rpm)								
Mass moment of inertia of the rotor										
I_V (about axis of rotation)	kg·m ²	0.0026	0.0059		0.0192		0.0370	0.0970		
I_V with optical speed system	kg·m ²	0.0027	0.0062		0.0196		0.0380	0.0995		
I_V with magnetic speed system	kg·m ²	0.0029	0.0065		0.0203	0.0201	0.0390	0.1		
Max. permissible static eccentricity of the rotor (radially)										
without speed measuring system	mm	± 2								
with optical speed measuring system (with or without reference impulse)	mm	± 1								
with magnetic speed measuring system	mm	± 0.7								
Permissible axial displacement between rotor and stator										
without speed measuring system	mm	± 3								
with optical speed measuring system (with or without reference impulse)	mm	± 2								
with magnetic speed measuring system	mm	± 1.5								

*) With T10FS/200 N-m to 10 k N-m, the nominal (rated) torque must not be exceeded. With T10FS/100 N-m, the nominal (rated) torque may be exceeded by 100 %.

10) Each type of irregular stress can only be permitted with its given static load limit (bending moment, lateral or axial load, exceeding the nominal (rated) torque) if none of the others can occur. Otherwise the limit values must be reduced. If for instance 30 % of the bending limit moment and also 30 % of the lateral limit force are present, only 40 % of the axial limit force are permitted, provided that the nominal (rated) torque is not exceeded. With the permitted bending moments, axial, and lateral limit forces, measuring errors of about 0.3 % of the nominal (rated) torque can occur.

11) Relative undulations within the range of the connecting flanges in accordance with DIN 45670/VDI 2059.

Dimensions Rotor (in mm; 1 mm=0.03937 inches)

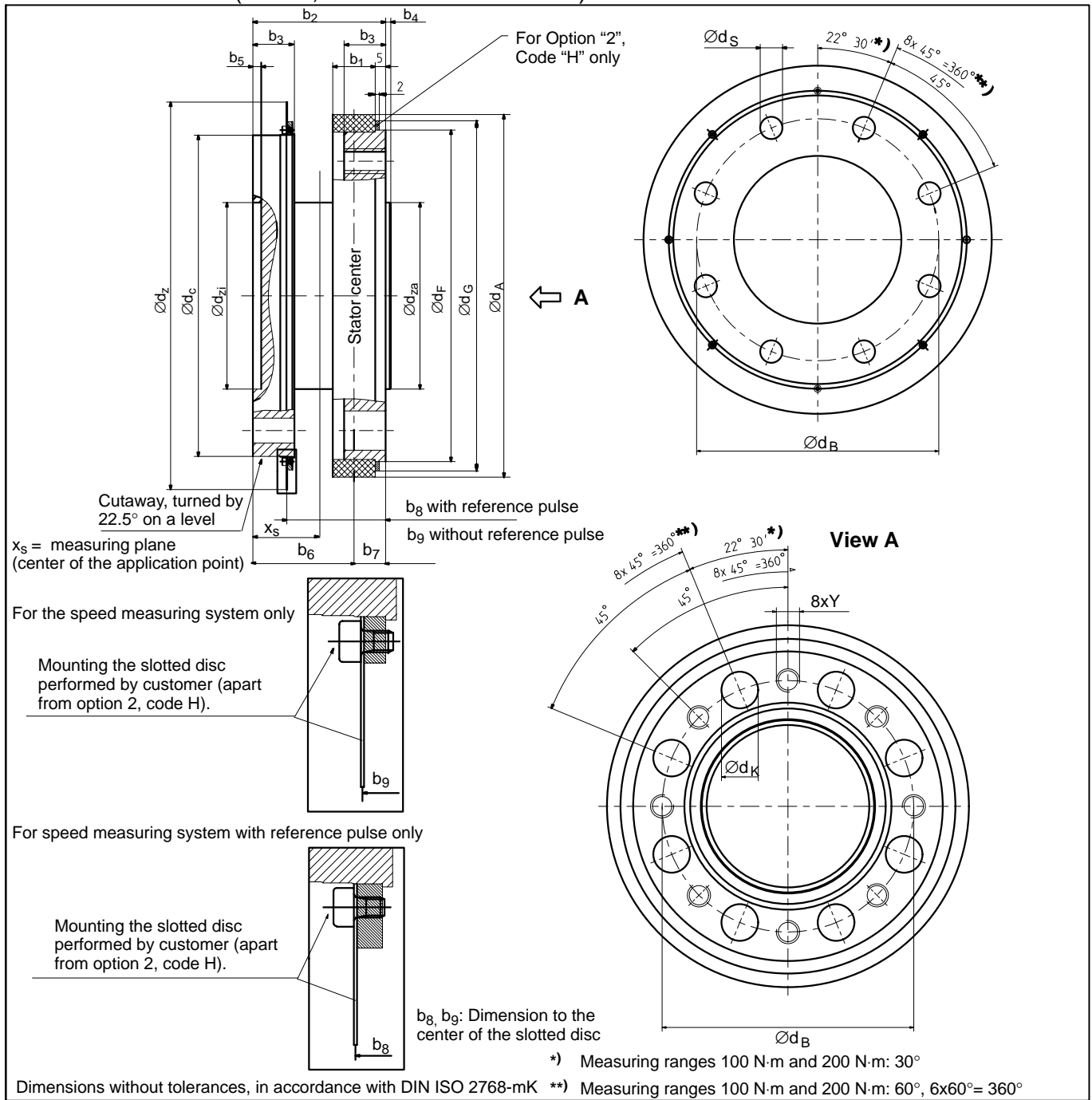

Measuring range	Dimensions in mm										
	b_1	b_2	b_3	$b_{4+0.4}$	b_5	b_6	b_7	b_8	b_9	x_s	Y
100 N·m / 200 N·m	17.5	60	18	2	4	46.3	13.7	47.2	47.2	30	M8
500 N·m / 1 kN·m	17.5	60	18	2	4	46.3	13.7	45.5	45	30	M10
2 kN·m / 3 kN·m	20.5	64	20	2.5	4	48.8	15.2	47.5	47	32	M12
5 kN·m	22.5	84	26	2.8	3	67.8	16.2	62.7	62.7	42	M14
10 kN·m	28.5	92	30	3.5	4	72.8	19.2	66.7	66.7	46	M16

Measuring range	Dimensions in mm									
	$\varnothing d_A$	$\varnothing d_B$	$\varnothing d_C$	$\varnothing d_F$	$\varnothing d_G$	$\varnothing d_K$	$\varnothing d_S^{C12}$	$\varnothing d_Z$	$\varnothing d_{za\ g5}$	$\varnothing d_{zi}^{H6}$
100 N·m / 200 N·m	119	84	99	101	110	14	8	131	57	57
500 N·m / 1 kN·m	139	101.5	120	124	133	17	10	151	75	75
2 kN·m / 3 kN·m	175	130	155	160	169	19	12	187	90	90
5 kN·m	209	155.5	180	188	-	22	14.2	221	110	110
10 kN·m	256	196	222	230	-	26	17	269	140	140

Dimensions rotor with magnetic speed measuring system (in mm 0.03937 inches)

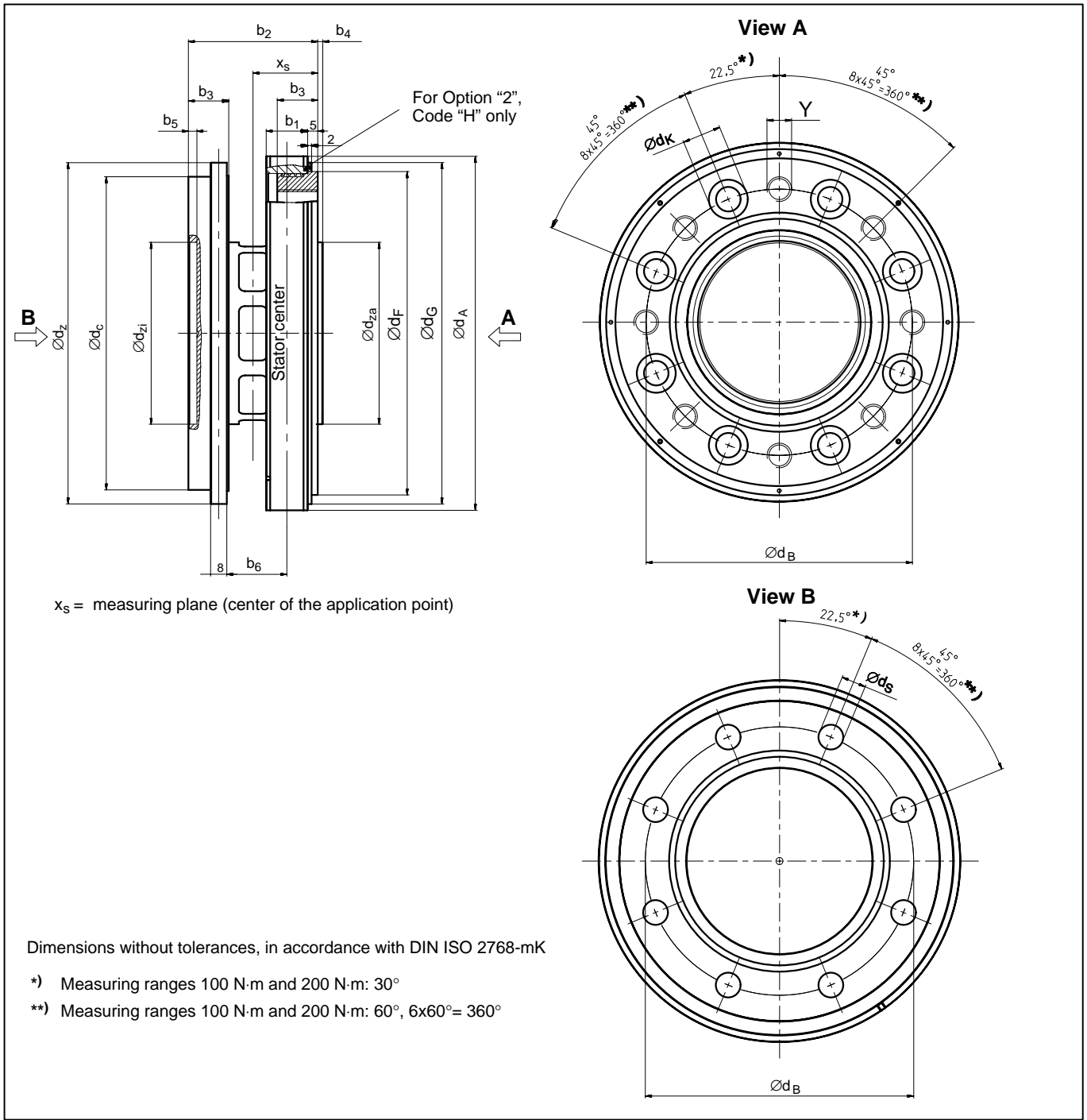

Measuring range	Dimensions in mm																	
	Ød _A	Ød _B	Ød _C	Ød _F	Ød _G	Ød _K	Ød _S ^{C12}	Ød _Z	Ød _{za g5}	Ød _{zi} ^{H6}	b ₁	b ₂	b ₃	b _{4+0.4}	b ₅	b ₆	x _S	Y
100 N·m / 200 N·m	119	84	99	101	110	14	8	112.9	57	57	17.5	60	18	2	4	31	30	6xM8
500 N·m / 1 kN·m	139	101.5	120	124	133	17	10	132.9	75	75	17.5	60	18	2	4	29	30	8xM10
2 kN·m / 3 kN·m	175	130	155	160	169	19	12	168.9	90	90	20.5	64	20	2.5	4	30	32	8xM12
5 kN·m	209	155.5	180	188	-	22	14	192.5	110	110	22.5	84	26	2.8	3	44	42	8xM14
10 kN·m	256	196	222	230	-	26	17	239.7	140	140	28.5	92	30	3.5	4	45	46	8xM16

Dimensions Stator (in mm; 1 mm=0.03937 inches)

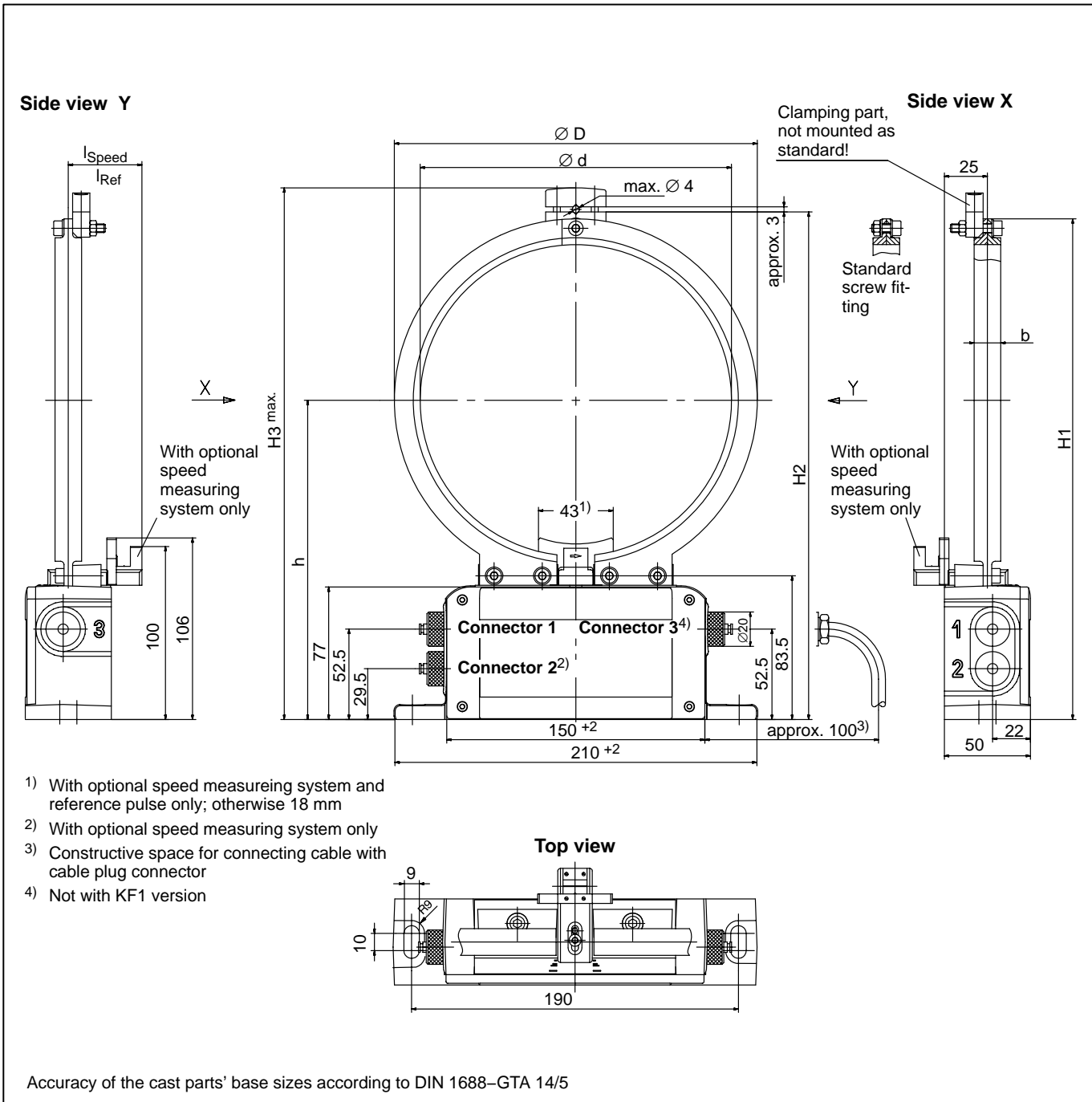

Measuring range	Dimension in mm								
	b	Ød	ØD	H1	H2	H3	h	l _{Speed}	l _{Ref}
100 N·m 200 N·m	17.5	125	155	235	239	253	157.5	42.5	42.5
500 N·m 1 kN·m	17.5	145	175	255	259	273	167.5	42	42.5
2 kN·m 3 kN·m	20.5	181	211	291	295	309	185.5	42.5	43
5 kN·m	22.5	215	245	324	329	343	202.5	57	57
10 kN·m	28.5	263	293	373	377	391	226.5	58	58

Dimensions of stator with magnetic speed measurement (in mm 0.03937 inches)

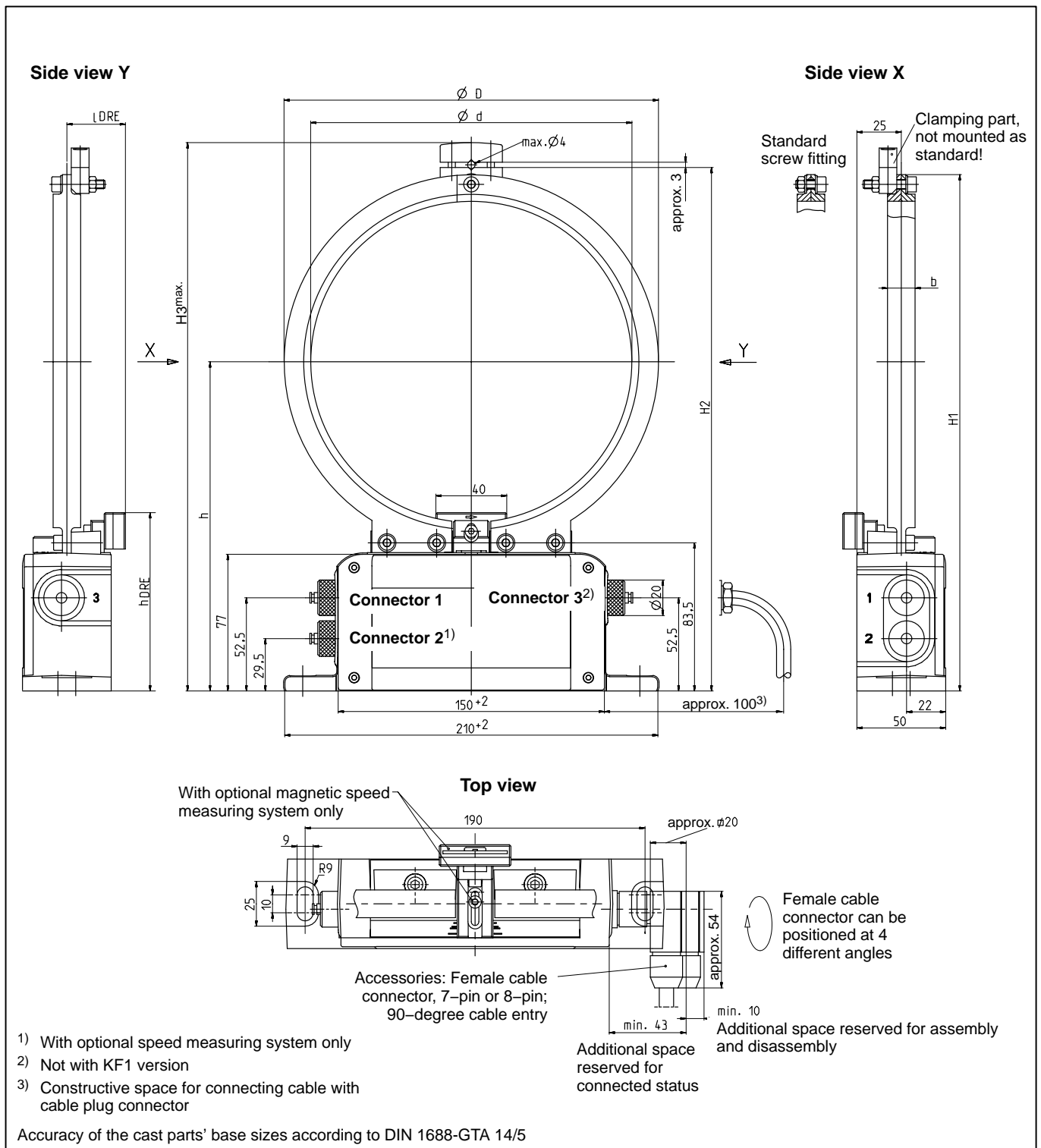

Measuring range	Dimensions in mm								
	b	Ød	ØD	H1	H2	H3	h	l _{DRE}	h _{DRE} *
100 N·m 200 N·m	17.5	125	155	235	239	253	157.5	38	100
500 N·m 1 kN·m	17.5	145	175	255	259	273	167.5	36	100
2 kN·m 3 kN·m	20.5	181	211	291	295	309	185.5	37	100
5 kN·m	22.5	215	245	325	329	343	202.5	51	105.5
10 kN·m	28.5	263	293	373	377	391	226.5	52	105.5

*) Can be adjusted by 1.5 mm at sensor head.

T10FS versions

T10FS version ^{*)}		KF1	SF1	SU2
Measured quantity				
Torque		■	■	■
Speed magnetic or optical (Option)			■	■
Speed and reference pulse (Option)			■	■
Power supply				
Excitation voltage 54 V _{pp} /14 kHz, square wave		■		
Supply voltage 18 V...30 V DC			■	■
Output signal				
10 kHz ± 5 kHz		■	■	■
± 10 V				■
Connecting cable	Torque	V1, V2, V3, V4	V5, V6	V5, V6
	Speed		W1, W2	W1, W2
	Speed and reference pulse		W5, W6	W5, W6

^{*)} Description of versions, see last page.

Screw fitting of the rotor

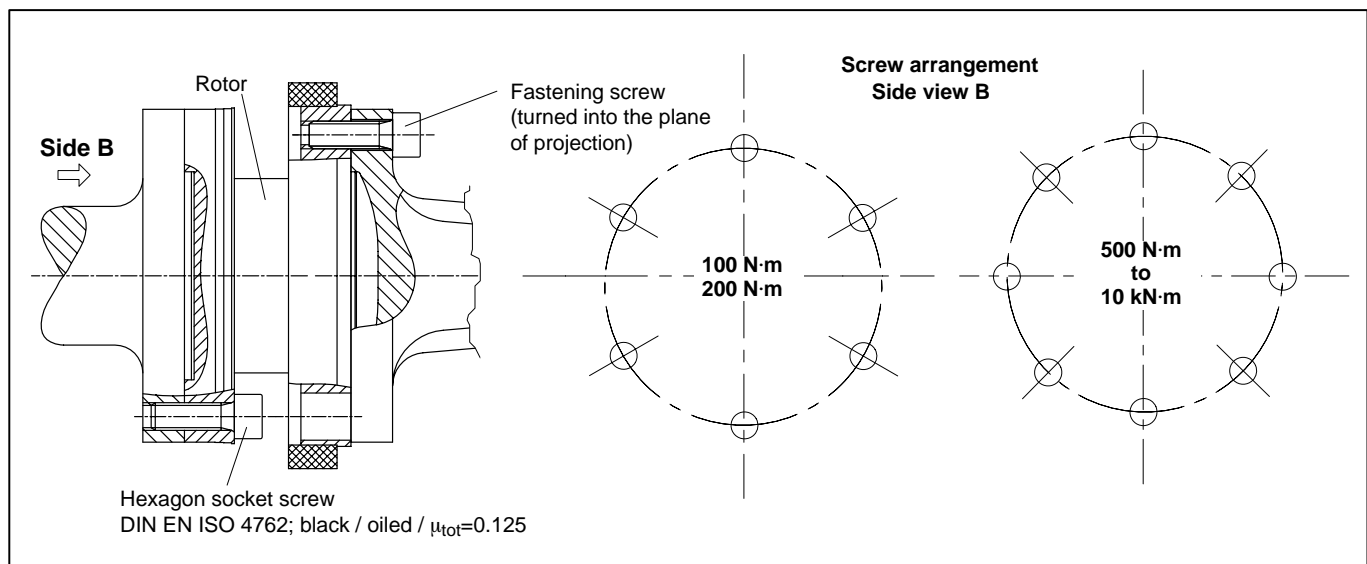

Nominal (rated) torque (N·m)	Fastening screws	Fastening screws class	Prescribed fastening torque (N·m)
100	M8	10.9	34
200			
500	M10	10.9	67
1 k			
2 k	M12	12.9	115
3 k			
5 k	M14	12.9	220
10 k	M16		340

Dimensions (in mm; 1mm=0.03937 inches)

Measuring range	Dimension "m" (mm)	Area free of metal parts (mm)	
		a	x
100 N·m 200 N·m	13.8	20	30
500 N·m 1 kN·m	13.8		28.5
2 kN·m 3 kN·m	15.3		28.5
5 kN·m	16.3		31.5
10 kN·m	19.3		34.5

It is essential to maintain the specified mounting dimensions to ensure proper functioning.

Flatness and concentricity tolerances

Measuring range	Circular run-out-axial tolerance (mm)	Circular run-out-radial tolerance (mm)
100 N·m	0.01	0.01
200 N·m	0.01	0.01
500 N·m	0.01	0.01
1 kN·m	0.01	0.01
2 kN·m	0.02	0.02
3 kN·m	0.02	0.02
5 kN·m	0.02	0.02
10 kN·m	0.02	0.02

Ordering number

Code	Option 1: Measuring range
100Q	100 N·m
200Q	200 N·m
500Q	500 N·m
001R	1 kN·m
002R	2 kN·m
003R	3 kN·m
005R	5 kN·m
010R	10 kN·m

Code	Option 2: Nominal speed
L	Normal speed depending on meas. range 8,000 rpm to 15,000 rpm
H	Normal speed depending on meas. range 12,000 rpm to 24,000 rpm

Code	Option 3: Electrical configuration
KF1	Output signal 10 kHz \pm 5 kHz, Supply voltage 14 kHz / 54 V; square wave
SF1	Output signal 10 kHz \pm 5 kHz, Supply voltage 18...30 V DC
SU2	Output signal 10 kHz \pm 5 kHz and \pm 10 V, Supply voltage 18...30 V DC

Code	Option 4: Accuracy
S	Standard
G	Increased accuracy ¹⁾ Lin. $< \pm 0.03$ % and $TK_0 < \pm 0.03$ %

Code	Option 5: Speed measuring system ²⁾
0	Without speed measuring system
1	With optical speed measuring system, 360 pulses/revolution
A	With optical speed measuring system, 360 pulses/revolution and reference pulse
M	With magnetic speed measuring system, 600/720 pulses/revolution

Code	Option 6: Connection cable
V0	Without connecting cable
V1	Torque connecting cable for KF1, 423-free ends, 6 m
V2 ^{*)}	Torque connecting cable for KF1, 423-free ends, max. 80 m
V3	Torque connecting cable for KF1, 423-MS3106PEMV, 6 m
V4 ^{*)}	Torque connecting cable for KF1, 423-MS3106PEMV, max. 80 m
V5	Torque connecting cable for SF1/SU2, 423-D-Sub 15P, 6 m
V6 ^{*)}	Torque connecting cable for SF1/SU2, 423-D-Sub 15P, max. 50 m
W1	One torque and speed cable each, 423-D-Sub 15P, 6 m
W2 ^{*)}	One torque and speed cable each, 423-D-Sub 15P, max. 50 m
W5	One cable for torque and speed each with reference pulse, 423-free ends, 6 m
W6 ^{*)}	One cable for torque and speed each with reference pulse, 423-free ends, max. 50 m

Code	Option 7: Accessories
N	Without accessories

- 1) With voltage output: Lin. $< \pm 0.05$ % ; $TK_0 < \pm 0.13$ %
 2) Only option 3, Code SF1, SU2

Order no.:

K-T10FS - [] [] [] [] - [] - [] [] [] [] - [] - [] [] [] [] - [] [] [] [] m^{*)}

Ordering example:

K-T10FS - [5] [0] [0] [Q] - [H] - [S] [F] [1] - [S] - [0] - [V] [5] - [N] [] [] [] [] m^{*)}

*) With V2, V4, V6, W2 and W6 selected, please specify desired cable length.

Accessories, to be ordered separately:

423G-7S cable socket, 7-pole, straight cable entry, for torque output (connector 1, 3), order no. 3-3101.0247

423W-7S cable socket, 7-pole, 90° cable entry, for torque output (connector 1, 3), order no. 3-3312.0281

423G-8S cable socket, 8-pole, straight cable entry, for speed output (connector 2), order no. 3-3312.0120

423W-8S cable socket, 8-pole, 90° cable entry, for speed output (connector 2), order no. 3-3312.0282

Raw cable Kab8/00-2/2/2, order no. 4-3301.0071

Modifications reserved.
 All details describe our products in general form only. They are not to be understood as express warranty and do not constitute any liability whatsoever.

Hottinger Baldwin Messtechnik GmbH

Im Tiefen See 45, D-64293 Darmstadt, Germany
 Tel.: +49 6151 8030; Fax: +49 6151 803 9100
 E-mail: support@hbm.com www.hbm.com



measurement with confidence