

# T20WN

## Torque Transducers



### Special features

- Nominal (rated) torques: 0.1 N·m, 0.2 N·m, 0.5 N·m, 1 N·m, 2 N·m, 5 N·m, 10 N·m, 20 N·m, 50 N·m, 100 N·m, 200 N·m
- Accuracy class: 0.2
- Contactless transmission of the measurement signal
- Measurement on rotating and stationary parts
- Cylindrical shaft ends for non-play friction joints
- Integrated measuring system for speed and angle of rotation
- Torque output signal:  $\pm 10$  V

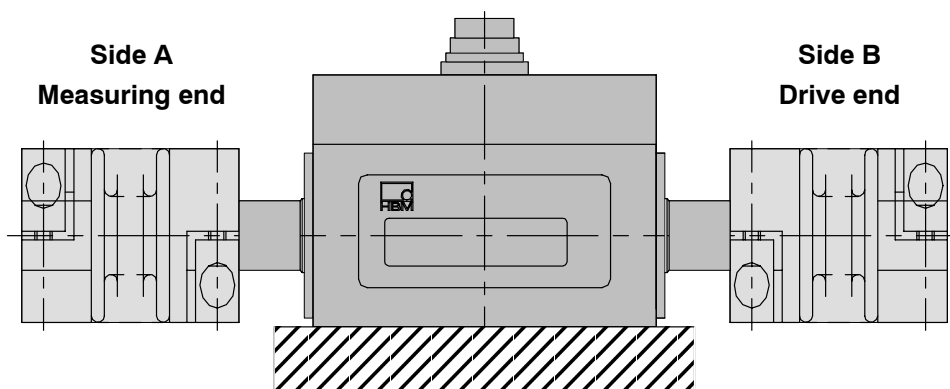

This example requires two of the couplings offered

## Specifications T20WN

Type	T20WN													
<b>Accuracy class</b>	0.2													
<b>Torque measuring system</b>														
<b>Nominal (rated) torque <math>M_{nom}</math></b> for reference only	N·m	0.1	0.2	0.5	1	2	5	10	20	50	100	200		
	ft·lb	0.075	0.15	0.375	0.75	1.5	3.75	7.5	15	37.5	75	150		
<b>Nominal (rated) sensitivity</b> (nominal (rated) signal range between torque = zero and nominal (rated) torque)	V	10												
<b>Characteristic tolerance</b> (deviation of the actual output quantity at $M_{nom}$ from the nominal (rated) signal range)	%	± 0.2												
<b>Output signal at torque = zero</b>	V	0 ± 0.2												
<b>Nominal (rated) output signal</b> with positive nominal (rated) torque	V	+10												
with negative nominal (rated) torque	V	-10												
<b>Load resistance</b>	MΩ	> 1												
<b>Long-term drift over 48 h</b>	mV	< ± 50												
<b>Cut-off frequency (-3 dB)</b>	Hz	200												
<b>Residual ripple</b>	mV <sub>pp</sub>	< 80												
<b>Temperature influence per 10 K in the nominal (rated) temperature range</b> on the output signal, related to the actual value of signal span	%	± 0.1												
on the zero signal, related to the nominal (rated) sensitivity	%	± 0.2												
<b>Power supply</b> Nominal (rated) excitation voltage (separated extra-low voltage)	V (DC)	12 (10.8...13.2)												
Release of calibration signal	V	5...13.2												
Current consumption in measuring mode	A	< 0.2												
Nominal (rated) power consumption	W	< 2.4												
Allowed residual ripple of excitation voltage	mV <sub>pp</sub>	200												
<b>Characteristic curve deviation</b> related to the nominal (rated) sensitivity	%	< ± 0.1												
<b>Variability</b> , related to the change in output signal	%	< ± 0.05												
<b>Calibration signal</b>	V	+10 ± 0.2%												
<b>Measuring system for speed/angle of rotation</b>														
<b>Measuring system</b>		Optical												
<b>Pulses per revolution</b>	Number	360												
<b>Output signal</b>	V	5 (asymmetrical); two square wave signals 90° phase shifted												
<b>Minimum speed for sufficient pulse stability</b>	rpm	0												
<b>Load resistance</b>	kΩ	> 10												
<b>Maximum measurable speed</b>	rpm	3000												
<b>General data</b>														
<b>EMC</b>														
<b>EMI (Immunity) (EN50082-2)</b>														
RF enclosure	V/m	10												
RF common mode	V <sub>pp</sub>	10												
Magnetic field	A/m	100												
Burst	kV	2/1												
DSE	kV	4/8												
<b>EME (Emission) (EN55011)</b>														
RFI-Voltage		Class B												
Field strength		Class B												
<b>Degree of protection according to EN 60529</b>		IP40												
<b>Weight</b> , approx.	kg	0.17					0.34				0.6			

## Specifications T20WN

Nominal (rated) torque $M_{nom}$ for reference only	N·m	0.1	0.2	0.5	1	2	5	10	20	50	100	200
	ft·lb	0.075	0.15	0.375	0.75	1.5	3.75	7.5	15	37.5	75	150
<b>Nominal (rated) temperature range</b>	°C [°F]	+5 [41]...+45 [113]										
<b>Service temperature range</b>	°C [°F]	0 [32]...+60 [140]										
<b>Storage temperature range</b>	°C [°F]	-5 [23]...+70 [158]										
<b>Impact resistance, test severity level to IEC 68; part 2-27; IEC 68-2-27-1987</b>												
Number of impacts	n	1000										
Duration	ms	3										
Acceleration (half-sine)	m/s <sup>2</sup>	650										
<b>Vibration resistance, test severity level to IEC 68, part 2-6; IEC 68-2-6-1982</b>												
Frequency range	Hz	5...65										
Duration	h	1.5										
Acceleration (amplitude)	m/s <sup>2</sup>	50										
<b>Nominal (rated) speed</b>	rpm	10 000										
<b>Load limits <sup>1)</sup></b>												
<b>Limit torque, related to <math>M_{nom}</math></b>	%	200 <sup>2)</sup>										
<b>Breaking torque, related to <math>M_{nom}</math></b>	%	> 280										
<b>Axial limit force</b>	kN	0.2	0.2	0.2	0.34	0.5	1.1	1.75	2.75	5.3	7.6	12.5
<b>Lateral limit force</b>	N	3.6	3.6	3.6	5.7	8.3	18.2	29	46	88	127	207
<b>Bending limit moment</b>	Nm	0.12	0.12	0.12	0.23	0.4	0.93	1.9	3.7	10	17	36
<b>Oscillation bandwidth according to DIN 50100 (peak-to-peak) <sup>3)</sup></b>	%	80										
<b>Mechanical values</b>												
<b>Torsional stiffness <math>C_T</math></b>	kN·m / rad	0.03	0.03	0.03	0.05	0.07	0.91	1.9	3.25	14	21.9	32.6
<b>Torsion angle at <math>M_{nom}</math></b>	degree	0.2	0.38	0.96	1.1	1.7	0.32	0.3	0.35	0.2	0.26	0.35
<b>Max. limits for relative shaft vibration (peak-to-peak) <sup>4)</sup></b>	μm	$s_{max} = \frac{4500}{\sqrt{n}}$										
<b>Rms value for the vibration velocity of the housing according to VDI 2056</b>	mm/s	$v_{eff} = \frac{\sqrt{n}}{3}$										
<b>Mass moment of inertia of the rotor (around the axis of rotation) with speed measuring system (<math>\times 10^{-3}</math>)</b>	gm <sup>2</sup>	0.06	0.06	0.06	0.063	0.068	6.1	6.13	6.23	53.7	54.6	57.2

<sup>1)</sup> Each type of irregular stress can only be permitted with its given statistic load limit values (bending moment, lateral or axial load, exceeding the nominal (rated) torque) if none of the others can occur. Otherwise the limit values must be reduced. If for instance 30 % of the bending limit moment and also 30 % of the lateral limit force are present, only 40 % of the axial limit force are permitted, provided that the nominal (rated) torque is not exceeded. With the permitted bending moments, axial and lateral limit forces, measuring errors of about 1 % of the nominal (rated) torque can occur.

<sup>2)</sup> Please observe the coupling's maximum torque ( $T_{Kmax}$ ).

<sup>3)</sup> The nominal (rated) torque must not be exceeded.

<sup>4)</sup> Relative undulations within the range of the adapter flange in accordance with DIN 45670/VDI 2059.

# Dimensions T20WN

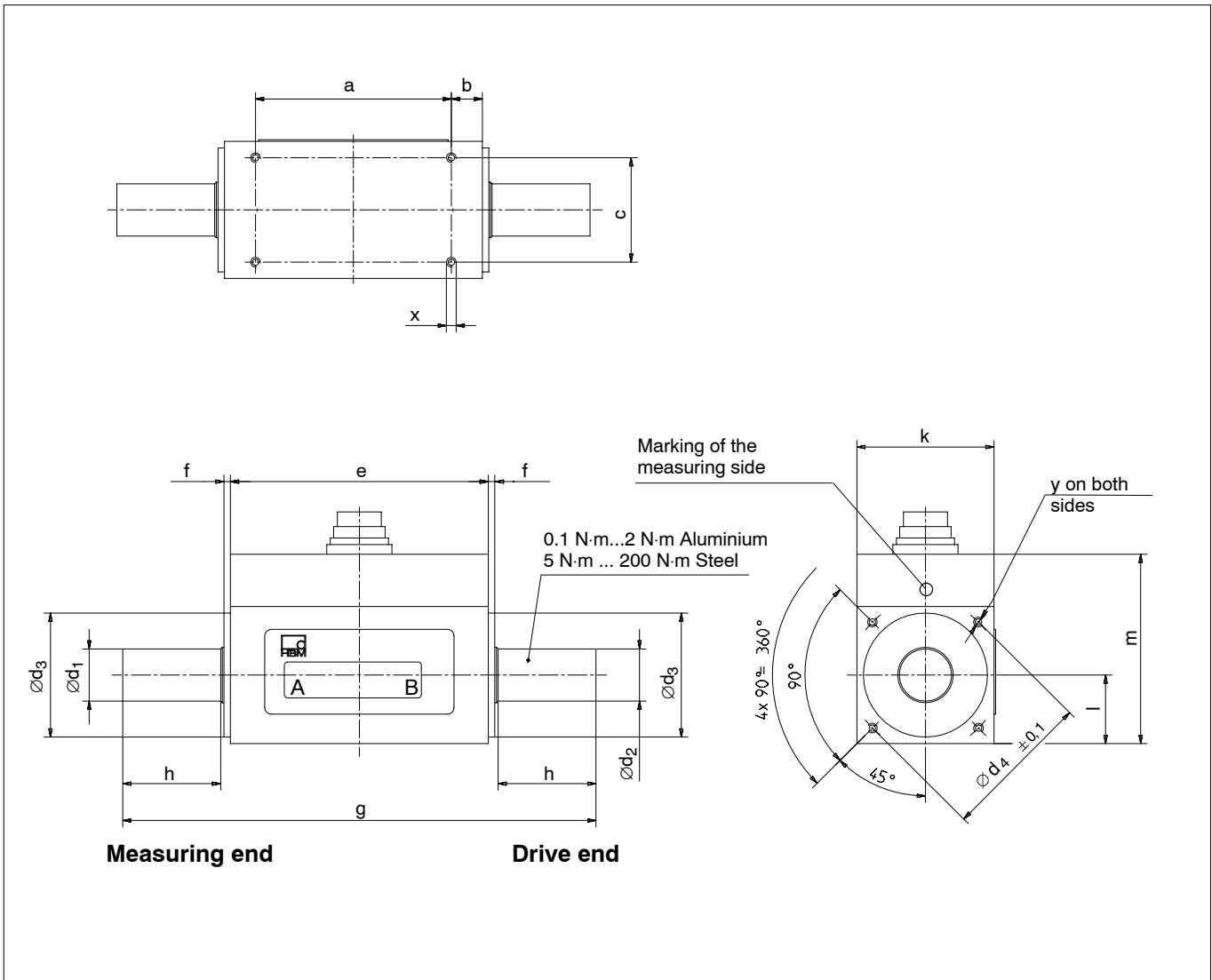

Measuring range (N·m)	Dimensions in mm															
	a	b	c	e ± 1	f	g	h	k	l	m	Ød <sub>1</sub> g6	Ød <sub>2</sub> g6	Ød <sub>3</sub> -0.1	Ød <sub>4</sub> ± 0.1	y	x
0.1	40	11	22	62	2	95	14	28	14	48.5	6	8	27	32	M3/6 depth	M3/5 depth
0.2	40	11	22	62	2	95	14	28	14	48.5	6	8	27	32	M3/6 depth	M3/5 depth
0.5	40	11	22	62	2	95	14	28	14	48.5	6	8	27	32	M3/6 depth	M3/5 depth
1	40	11	22	62	2	95	14	28	14	48.5	6	8	27	32	M3/6 depth	M3/5 depth
2	40	11	22	62	2	95	14	28	14	48.5	6	8	27	32	M3/6 depth	M3/5 depth
5	60	9.5	32	79	2	145	30	42	21	58	16	16	38	46	M3/6 depth	M3/6 depth
10	60	9.5	32	79	2	145	30	42	21	58	16	16	38	46	M3/6 depth	M3/6 depth
20	60	9.5	32	79	2	145	30	42	21	58	16	16	38	46	M3/6 depth	M3/6 depth
50	42	15	40	72	3	170	45	56	28	73	26	26	54	65	M4/8 depth	M4/8 depth
100	42	15	40	72	3	170	45	56	28	73	26	26	54	65	M4/8 depth	M4/8 depth
200	42	15	40	72	3	170	45	56	28	73	26	26	54	65	M4/8 depth	M4/8 depth

## Specifications VK20

Type		<b>VK20</b>
Supply voltage	V	24
Supply voltage range	V	14 ... 30
Current consumption	mA	max. 300, typ. 150
Power consumption	W	max. 9
Transducers that can be connected max. length of cable to the transducer	m	T20WN 50
<b>Outputs</b>		
Torque Load-carrying capacity Accuracy max. cable length	V m	-10..+10 V see T20WN see T20WN 500
Speed/angle of rotation Level Load-carrying capacity max. cable length	V mA m	2 impulse signals 90° phase shifted for detection of direction of rotation 0/5 (complementary signals RS422) max. 20 500
External calibration signal trigger Off On	V V	less than 2 V (0 V ... 2 V) greater than 4 V (4 V ... 30 V)
Internal calibration signal trigger		by probe
Nominal (rated) temperature range	°C [°F]	-10 ... 60 [14 ... 140]
Operating temperature range	°C [°F]	-10 ... 60 [14 ... 140]
Storage temperature range	°C [°F]	-20 ... 70 [-4 ... 158]
Degree of protection acc. to EN 60 529		IP65
Interference suppression		under EN55011, class B
Electromagnetic compatibility		under EN50082-2
Weight	g	approx. 500

## Dimensions VK20

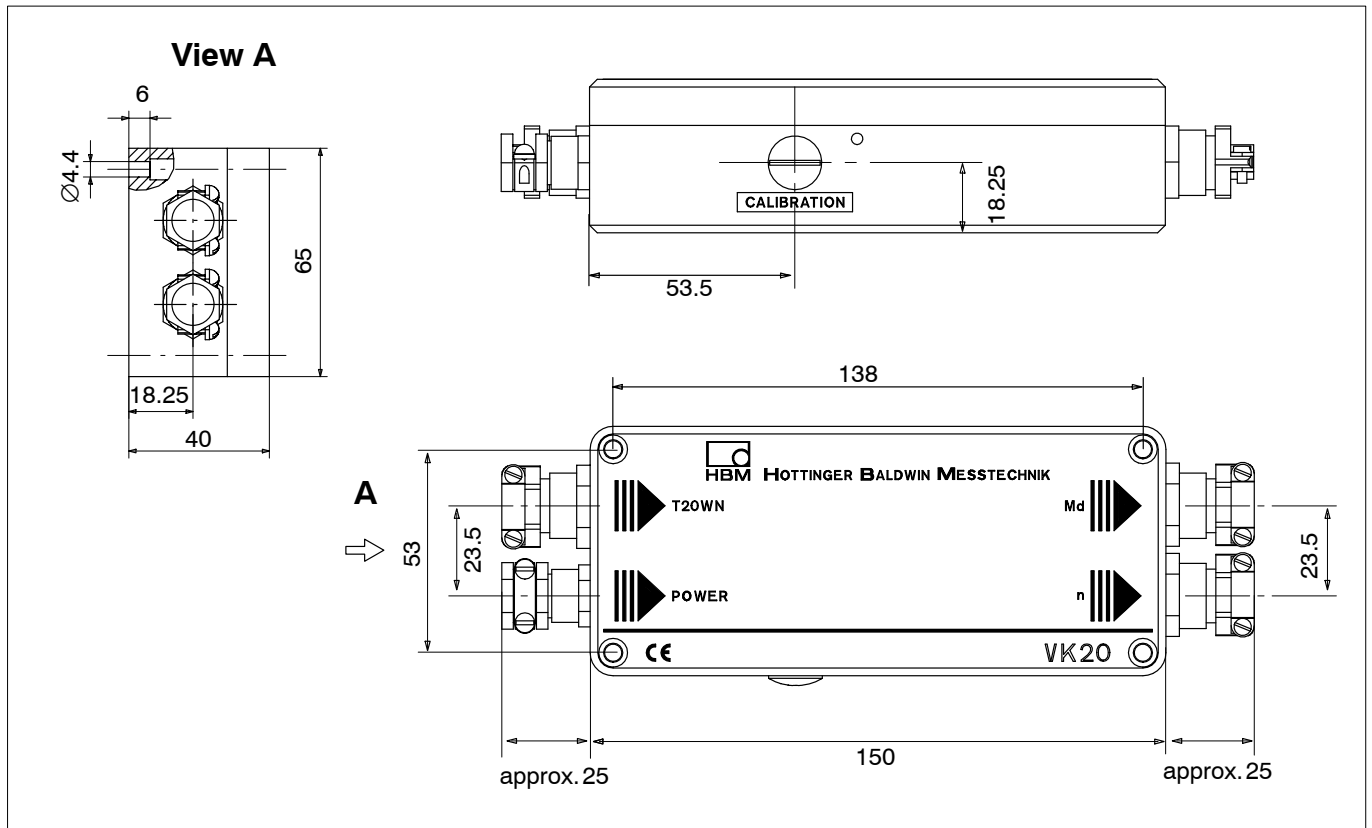

## Bellow couplings

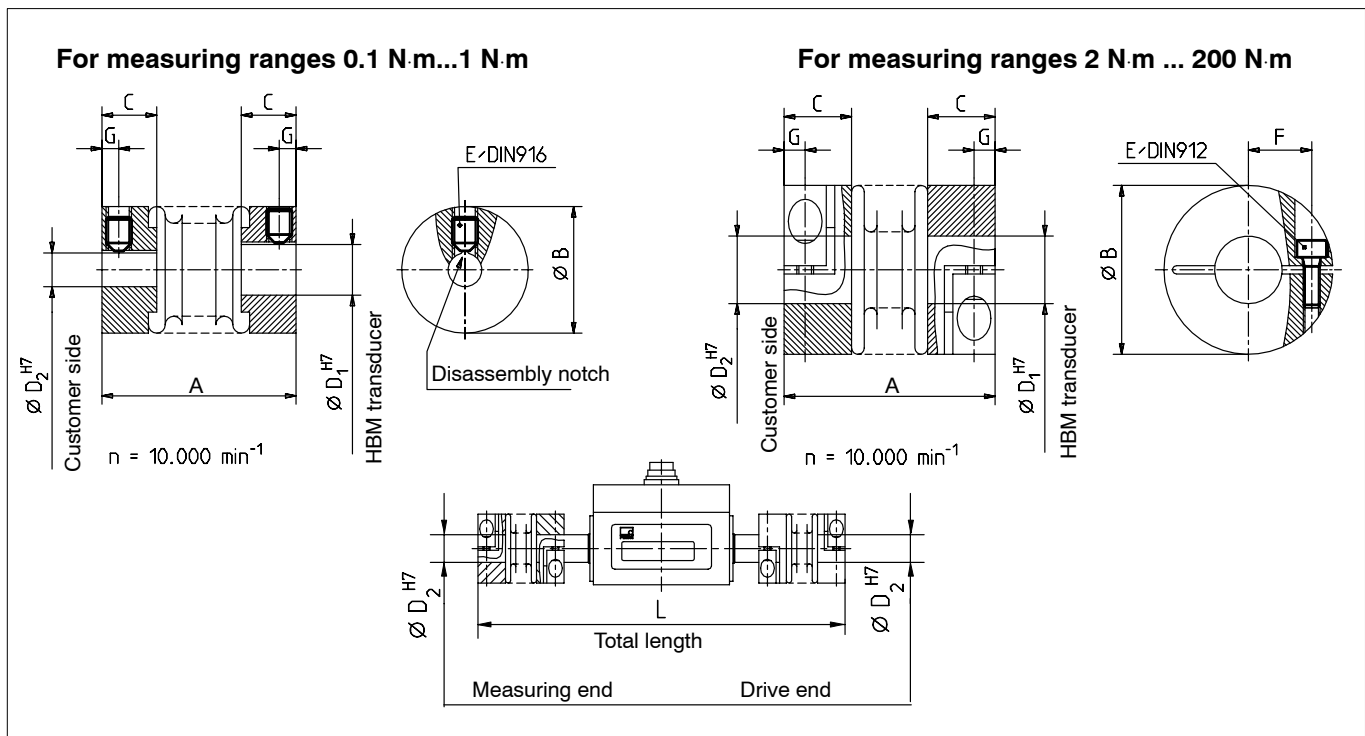

## Dimensions

Measuring range [N·m]	Parts-No.	Dimensions in mm									
		A	ØB	C	ØD <sub>1</sub>		ØD <sub>2</sub>	E	F	G	L
					Measuring end T20WN	Drive end T20WN	variable from - to				
0.1	3-4412.0001	23 <sub>-1</sub>	15	6.5	6	8	3-9	M3	-	2	128
0.2											
0.5											
1	3-4412.0002	25 <sub>-1</sub>	15	6.5	6	8	3-9	M3	-	2	132
2	3-4412.0003	40 <sub>-1</sub>	25	13	6	8	3-12.7	M3	8	4	149
5	3-4412.0004	50 <sub>-1</sub>	40	16	16	16	5-22	M4	15	5	213
10											
20	3-4412.0005	69 <sub>-2</sub>	56	21	16	16	10-32	M6	19	7.5	241
50	3-4412.0006	80 <sub>-2</sub>	66	23.5	26	26	12-32	M8	23	9.5	283
100	3-4412.0007	93 <sub>-2</sub>	82	28	26	26	19-40	M10	27	11	300
200	3-4412.0008	109 <sub>-2</sub>	110	35	26	26	24-56	M12	39	13	318

Please specify upon order: D<sub>2</sub> connecting holes as specified by customer within the stated limits; H7 boring tolerance.

By using only **one** bellow coupling, please indicate the construction side of the coupling:

**Measuring end = 6 mm / Drive end = 8 mm**

## Specifications

Measuring range [N·m]	Coupling torque maximum $T_{Kmax}$ [N·m]	Mass moment of inertia [kg·cm <sup>2</sup> ]	Weight [g]	Torsional stiffness [kNm/rad]	Max. permitted misalignment			Spring stiffness		Material of coupling hub and fastening ring	Tightening torque of clamping screws [N·m]
					axial [mm]	radial [mm]	angular [deg]	axial [N/mm]	radial [N/mm]		
0.1	0.5	0.012	6	0.21	0.5	0.2	1.5	13.4	47.7	Aluminium	0.35
0.2											
0.5											
1	1	0.018	7	0.38	0.5	0.2	1.5	27.4	84.3		0.75
2											
2	2	0.27	38	1.30	0.6	0.2	1.5	20.6	88		0.75
5											
10	10	1.6	120	9.05	1	0.2	1.5	33.3	389		1.5
20											
50											
50	60	2.0	400	72	1.5	0.15	1.5	67	679	35	
100											
100	150	20	1600	141	2	0.15	1.5	77	960	75	
200											
200	300	40	3800	157	2	0.15	1.5	124	2940	Steel	120

## General notes

- Install the shafts in the coupling hubs before fastening the couplings' clamping screws!
- Do not stretch the bellow couplings beyond the specified permissible elasticities.
- The input and output shafts must be free from grease and burrs.
- The shaft diameters should be made with a j6 tolerance to obtain the H7/j6 preference fit.

## Mounting position

The T20WN Torque Transducer with bellow couplings can be used in any mounting position (horizontal, vertical or oblique). With vertical or oblique operation, please ensure that additional masses are sufficiently supported.

## Equipment as supplied

The couplings and the torque transducer are delivered separately ex-works.

## Accessories T20WN, to be ordered separately

Connection cable, 5 m long, order no. 3-3301.0158

Connection cable, 10 m long, order no. 3-3301.0159

Cable socket, 12-pole (Binder), order no. 3-3312.0268

Terminal box, order no. 1-VK20

Bellows couplings

## Accessories VK20, to be ordered separately

Mains device (14.4 V=/300 mA), order no. 3-3318.0002

Connection cable, 1.5 m long (D-Sub, 15-pole – free ends), order no. 1-Kab151-1.5

Connection cable, 1.5 m long (SUBCON5 – free ends), order no. 1-Kab152-1.5

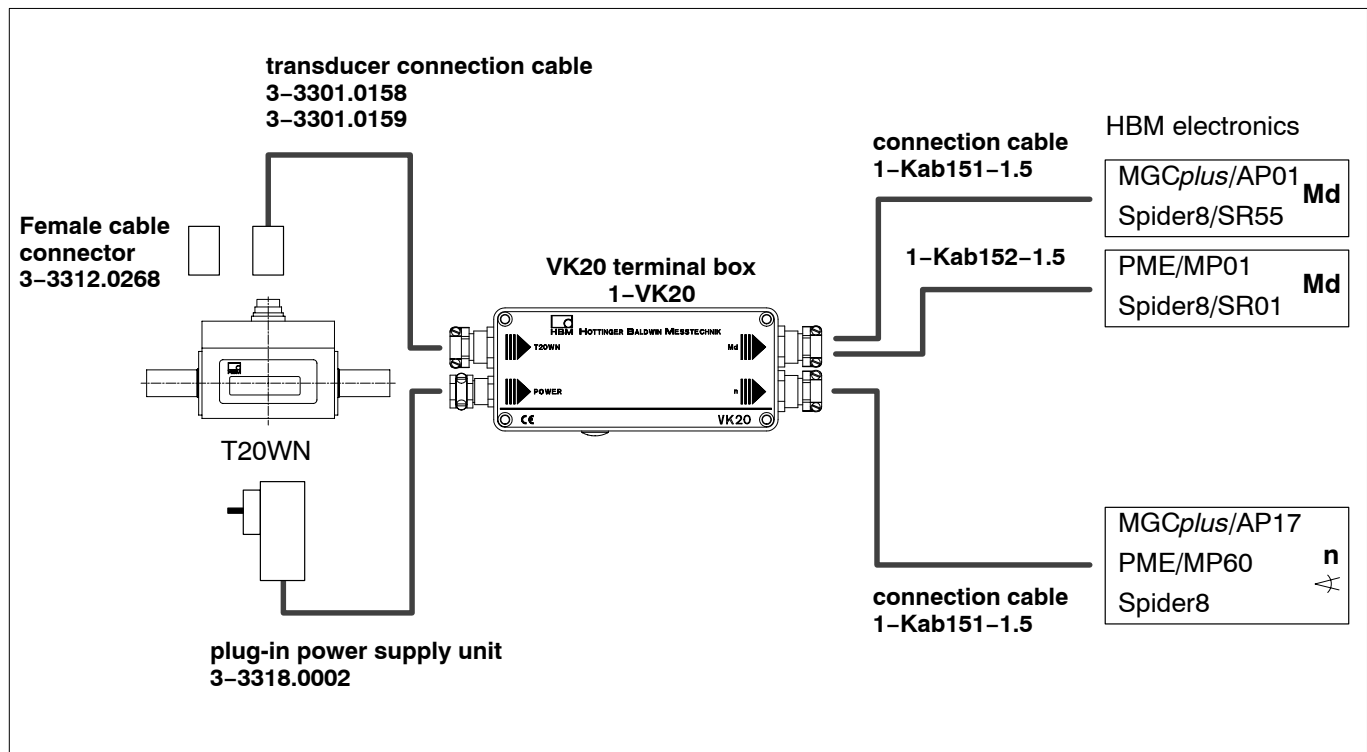

Modifications reserved.

All details describe our products in general form only. They are not to be understood as express warranty and do not constitute any liability whatsoever.

**Hottinger Baldwin Messtechnik GmbH**

Im Tiefen See 45, D-64293 Darmstadt, Germany

Tel.: +49 6151 8030; Fax: +49 6151 803 9100

E-mail: support@hbm.com www.hbm.com



measurement with confidence