

Mounting instructions

Torque Flange

T10FH



A2037-2.0 en



Safety instructions	5
1 Scope of supply	9
2 Application	9
3 Structure and mode of operation	10
4 Mechanical installation	11
4.1 Conditions on site	12
4.2 Mounting position	12
4.3 Mounting sequence	12
4.4 Preparing for the rotor mounting	15
4.5 Mounting the rotor	19
4.6 Installing the stator	21
4.7 Installing the clamp fixture	23
4.8 Aligning the stator (speed measuring system)	24
5 Electrical connection	26
5.1 General hints	26
5.2 Shielding design	26
5.3 Connector pin assignment Option 3, Code SU2	27
5.4 Connector pin assignment Option 3, Code PNJ	29
5.5 Supply voltage pin assignment (Option 3, Code SU2)	29
5.5.1 Supply voltage for self-contained operation	29
5.6 Supply voltage (Option 3, Code PNJ)	30
6 TEDS transducer identification (Option 3, Code PNJ)	30
6.1 Hierarchy of user rights	30
6.1.1 Standard rights (USR level)	30
6.1.2 Calibration rights (CAL level)	30
6.1.3 Administrator rights (ID level)	31
6.2 Content of the TEDS memory as defined in IEEE 1451.4	31
7 Shunt signal (Option 3, Code SU2)	34
7.1 Shunt signal	34
8 Settings (Option 3, Code SU2)	35
8.1 Torque output signal	35
8.2 Setting up the zero point	35

8.3	Function testing	36
8.3.1	Power transmission	36
8.3.2	Checking the speed measuring system	37
8.4	Speed measuring system	38
8.5	Form of speed output signal	38
8.6	Type of speed output signal	38
9	Loading capacity	39
9.1	Measuring dynamic torque	39
10	Maintenance	40
11	Specifications	41
12	Dimensions Rotor T10FH rotating; option 2, code L	48
13	Dimensions Rotor T10FH non-rotating; option 2, code N	49
14	Mounting Dimensions	50
15	Supplementary technical information; option 2, code L	51
15.1	Output signals	51
15.1.1	Output MD for torque (connector 1)	51
15.1.2	Output N for rotation speed (connector 2)	52
15.2	Circular run-out values	53
16	Order number	54
17	Accessories	55

Safety instructions

Appropriate use

The T10FH Torque Flange may be used for torque-measurement and directly related control and regulation tasks only. Any other use is **not** appropriate.

To ensure safe operation, the transducer may only be used according to the specifications given in this manual. When using the transducer, the legal and safety regulations for the respective application must also be observed. The same applies if accessories are used.

The transducer is not a safety device in accordance with the regulations for appropriate use. For correct and safe operation of these transducers it is essential to ensure technically correct transportation, storage, installation and fitting, and to operate all equipment with care.

This is a Class B EMC product. In a domestic environment this product may cause radio interference in which case the user may be required to take adequate measures.

General dangers in the case of non-observance of the safety instructions

The transducer comply with the state of the art and is operationally reliable. If the transducer is used and operated inappropriately by untrained personnel, residual dangers may arise.

Anyone responsible for installing, operating, maintaining or repairing these transducers must be sure to have read and understood the operating manual and in particular the notes on safety.

Residual dangers

The scope of performance and supply of these transducers covers only part of the torque measurement technology. In addition, those involved in planning, constructing and operating the safety engineering aspects of torque measurement technology must design, produce and take responsibility for such measures in order to minimize potential residual dangers. Prevailing regulations must be complied with at all times. There must be a clear reference to the residual dangers connected with measurement technology.

In this manual, the following symbols are used to refer to residual dangers:



Symbol: **DANGER**

Meaning: **Maximum danger level**

Warns of an **imminently** dangerous situation in which failure to comply with safety requirements **will result in** death or serious physical injury.



Symbol: **WARNING**

Meaning: **Dangerous situation**

Warns of a **potentially** dangerous situation in which failure to comply with safety requirements **can result in** death or serious physical injury.



Symbol: **CAUTION**

Meaning: **Potentially dangerous situation**

Warns of a potentially dangerous situation in which failure to comply with safety requirements **could result in** damage to property or some form of physical injury.

Symbols pointing out notes on use and waste disposal as well as useful information:



Symbol: **NOTE**

Means that important information about the product or its handling is being given.



Symbol: **CE mark**

The CE mark enables the manufacturer to guarantee that the product complies with the requirements of the relevant EC directives (the declaration of conformity is available at <http://www.hbm.com/HBMdoc>).

**Symbol:**

Meaning: **Statutory marking requirements for waste disposal**

National and local regulations regarding the protection of the environment and recycling of raw materials require old equipment to be separated from regular domestic waste for disposal.

For more detailed information on disposal, please contact the local authorities or the dealer from whom you purchased the product.

Reconstruction and modifications

HBM's express consent is required for modifications affecting the transducers' construction and safety. HBM does not take responsibility for damage resulting from unauthorized modifications.

Qualified personnel

The transducers may be used by qualified personnel only; the technical data and the special safety regulations must be observed in all cases. When using the transducers, the legal and safety regulations for the respective application must also be observed. The same applies if accessories are used.

Qualified personnel means: personnel familiar with the installation, fitting, start-up and operation of the product, and trained according to their job.

Prevention of accidents

According to prevailing accident prevention regulations, after fitting the T10FH torque flange a cover must be fitted as follows:

- The cover must not be able rotate.
- The cover shall protect against crushing or cutting and provide protection against parts that might come loose.
- The cover shall be installed at a safe distance from moving parts or shall prevent anyone putting their hand inside.
- The cover shall even be fitted if the moving parts are installed in areas to which persons do not usually have access.

The above regulations may only be disregarded if machine parts are already sufficiently protected owing to the design of the machine or because other precautions have been taken.

Guarantee

In the event of a claim, the guarantee can only be considered if the torque flanges are returned in its original packing.

1 Scope of supply

- Torque flange
- Mounting Instructions
- Test record
- Optional:
 - Magnetic speed measuring system
 - DKD calibration certificate in accordance with DIN 51 309 or EA-10/14:
Class 0.5

2 Application

The T10FH torque flange records static and dynamic torque on fixed or rotating shafts and also return RS422 signals with direction of rotation information to determine the speed.

The rotating version (frequency and voltage output) is designed for:

- marine engine test benches
- transmissions
- pump test benches

The non-rotating version (mV/V output signal) is designed for:

- calibration tasks
- torque reference transducers
- torque transfer transducers

Designed to work without bearings and with contactless digital signal transmission, the torque measuring system is maintenance-free.

The torque flange is supplied for nominal (rated) torques of 100 kN·m to 300 kN·m. Depending on the nominal torque, maximum speeds of up to 3 000 min⁻¹ are permissible.

The T10FH torque flange is reliably protected against electromagnetic interference. It has been tested with regard to EMC according to the relevant European standards, and carries the CE mark.

3 Structure and mode of operation

The torque flange (Option 2, code N) consists of two separate parts: the rotor and the stator.

The rotor comprises the measuring body and the signal transmission elements.

Strain gages (SGs) are mounted on the measuring body. The rotor electronics for transmitting the excitation voltage and the measurement signal are located centrally in the flange. The transmitter coils for the noncontact transmission of excitation voltage and measurement signal are located on the measuring body. The signals are sent and received by a separable antenna ring. The antenna ring is mounted on a housing that includes the electronic system for voltage adaptation and signal conditioning.

Connectors for the torque signal, the voltage supply and the speed signal (option) are located on the stator. The antenna ring should be mounted more or less concentrically around the rotor (see chapter 4).

Speed measurement is effected by a magnetic field dependent resistor and a ring gear attached to the rotor.

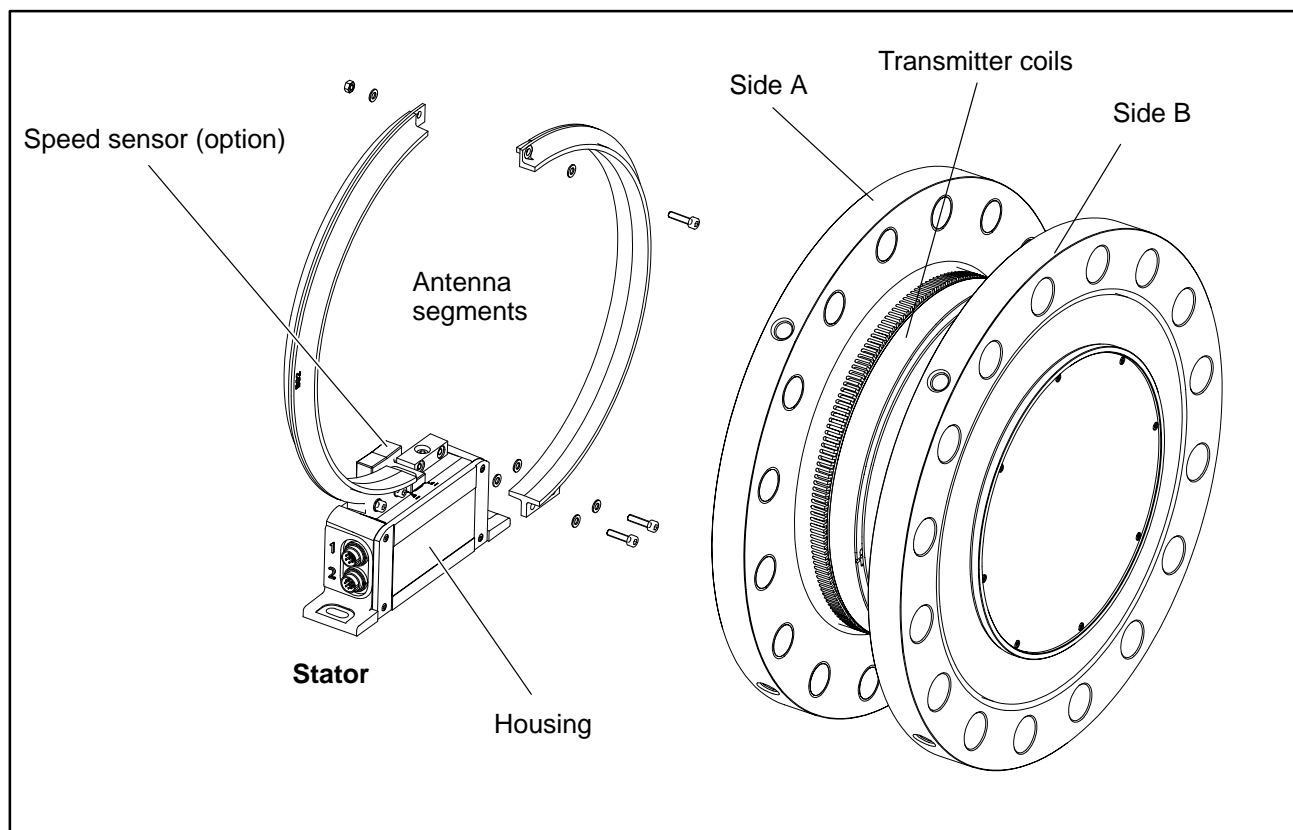

Fig. 3.1: Mechanical construction, exploded view (rotating version)

4 Mechanical installation



WARNING

Handle the torque flange carefully. The transducer might suffer permanent damage from mechanical impact (e.g. dropping), chemical effects (e.g. acids, solvents) or thermal effects (e.g. hot air, steam).

With alternating loads, you should cement the rotor connectionscrews into the mating thread with a screw locking device (medium strength) to exclude prestressing loss due to screw slackening.

An appropriate shaft flange enables the T10FH torque flange to be mounted directly. It is also possible to directly mount a joint shaft or relevant compensating elements on the opposite flange (using an intermediate flange when required). Under no circumstances must the permissible limits specified for bending moments, lateral and longitudinal forces be exceeded. Due to the torque flange's high torsional stiffness, dynamic shaft train changes are kept to a minimum.



CAUTION

Check the effect on speeds and natural torsional oscillations critical to bending, to prevent the transducer being overloaded by increases in resonance.



NOTE

Even if the unit is installed correctly, the zero point adjustment made at the factory can shift by approx. ± 150 Hz. If this value is exceeded, we advise you to check the mounting conditions. If the residual zero offset when the unit is removed is greater than ± 50 Hz, please send the transducer back to the Darmstadt factory for testing.

For correct operation, do in any case observe the mounting dimensions (see page 50).

4.1 Conditions on site

The T10FH torque flange is protected to IP54 according to EN 60529. Protect the transducer from coarse dirt, dust, oil, solvents and moisture. During operation, the prevailing safety regulations for the security of personnel must be observed (see "Safety Instructions").

There is wide ranging compensation for the effects of temperature on the output and zero signals of the T10FH torque flange (see specifications on page 41). This compensation is carried out at static temperatures. This guarantees that the circumstances can be reproduced and the properties of the transducer can be reconstructed at any time.

If there are no static temperature ratios, for example, because of the temperature differences between flange A and flange B, the values given in the specifications can be exceeded. Then for accurate measurements, you must ensure static temperature ratios by cooling or heating, depending on the application. As an alternative, check thermal decoupling, by means of heat radiating elements such as multiple disc couplings.

4.2 Mounting position

The transducer can be mounted in any position. With clockwise torque, the output frequency is 10...15 kHz (Option 3, Code SU2). In conjunction with HBM amplifiers or when using the voltage output, a positive output signal (0 V to +10 V) is present.

With counterclockwise torque, the output frequency is 5 kHz to 10 kHz.

In the case of the speed measuring system, an arrow is attached to the head of the sensor to clearly define the direction of rotation. When the transducer rotates in the direction of the arrow, a positive speed signal is output.

With the non-rotating version, there is a positive output signal in mV/V for clockwise torque.

4.3 Mounting sequence

As the diameter of the antenna ring is less than the flange diameter of the rotor, the antenna ring must be dismantled for mounting. If access to the rotor in its installed state is difficult, we recommend mounting the antenna ring beforehand.



CAUTION

When installing the rotor, make sure that you do not damage the stator. It is essential in this case to comply with the notes on assembling the antenna segments (see "Installing the stator", page 21).

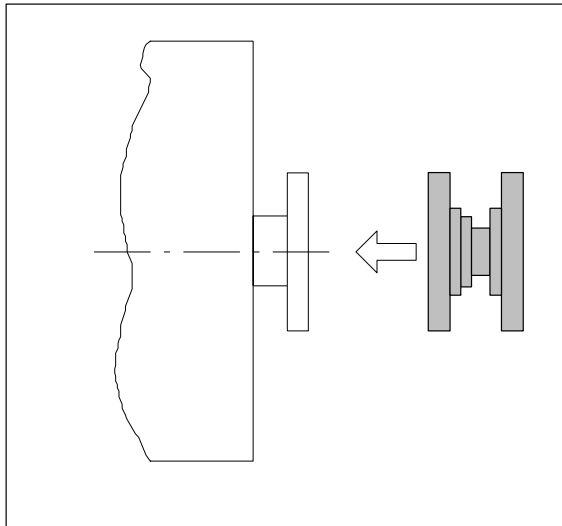

1. Install rotor

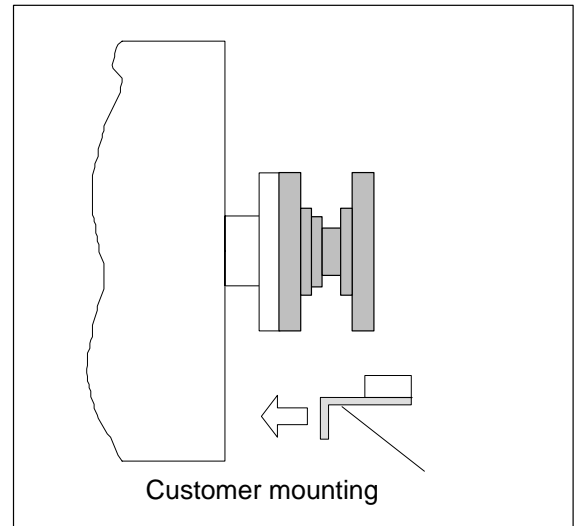

2. Install stator mounting

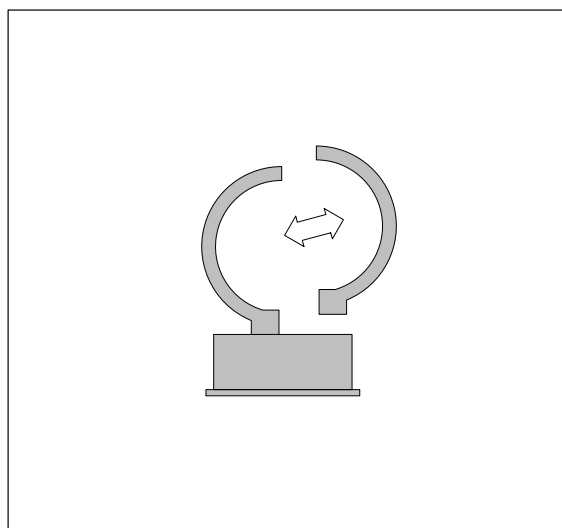

3. Remove one antenna segment

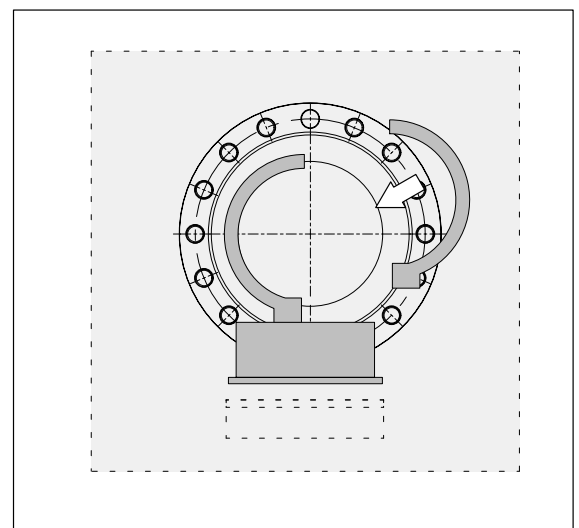

4. Install antenna segment around shaft train

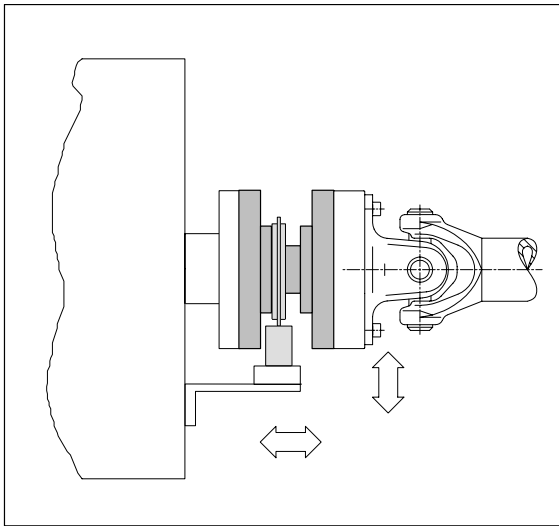

5. Align stator and finish installation

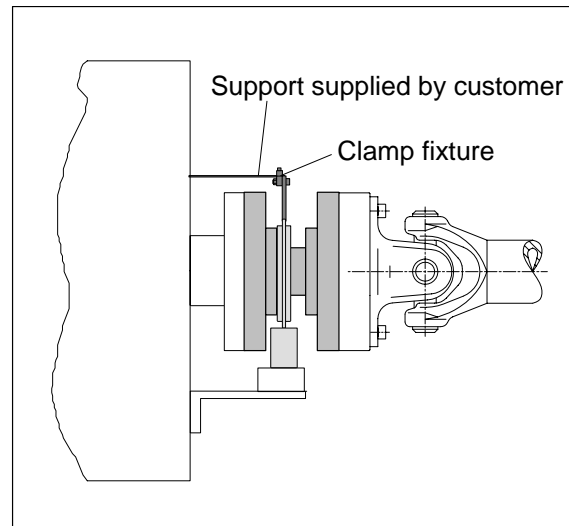

6. Install clamp fixture

4.4 Preparing for the rotor mounting



CAUTION

The rotor is heavy (as much as 148 kg, depending on the measuring range)! Use a crane or other suitable lifting equipment to lift it out of its packaging and install it.

When working with the crane, be sure to meet relevant safety requirements and wear safety boots.

1. Remove the top layer of foam packaging.



Fig. 4.1: T10FH packaging

2. Fasten two equal-length ropes of sufficient bearing strength to the eye-bolts (each of the two ropes must be able to bear the full weight of the rotor) and hoist the rotor out of its packaging with the crane (see Fig. 4.2).

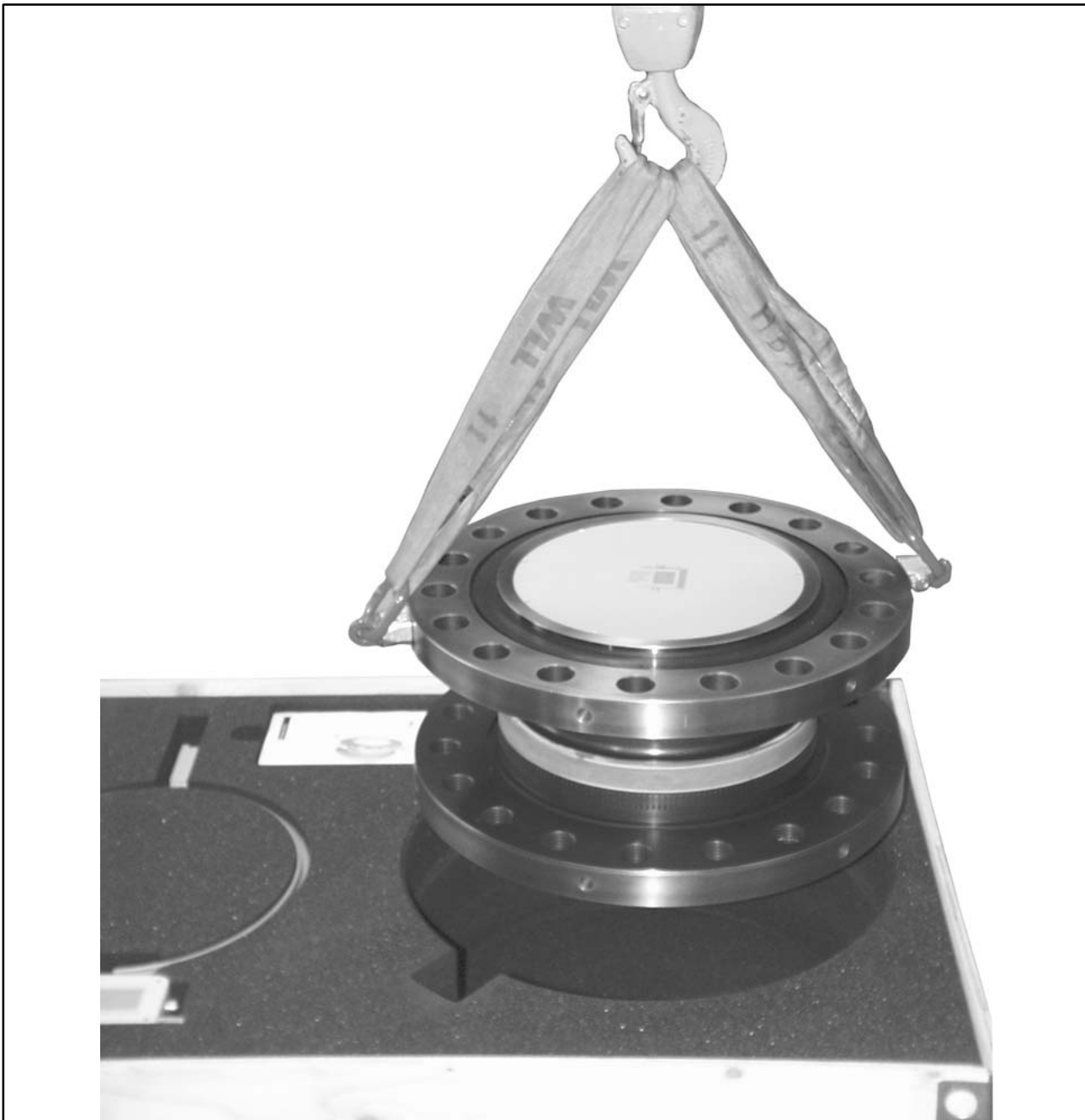

Fig. 4.2: Hoist the rotor out of its packaging

3. Place the rotor onto a clean and stable base.
4. Remove one of the eyebolts.
5. Carefully lift the rotor until it hangs freely.
6. Carefully tilt the rotor by lowering it over the flange edge until it rests horizontally on both outer flange surfaces (see Fig. 4.3).



CAUTION

Crush hazard. Keep your hands and feet a safe distance away from the rotor.



Fig. 4.3: Tilt rotor

7. Secure the rotor with wedges to stop it rolling away.
8. Screw the second eyebolt back into the tapped holes in the outer flange surface.
9. Fasten the rotor to the hook of the crane with two equal-length ropes. The rotor is now prepared for horizontal installation (see Fig. 4.4).



Fig. 4.4: Fastening for horizontal installation



CAUTION

You must remove the eyebolts after mounting! Keep them safe for later use.

4.5 Mounting the rotor



NOTE

In general, the rotor identification plate is no longer visible after installation. This is why we include with the rotor additional stickers with the important ratings, which you can attach to the stator or any other relevant test-bench components. You can then refer to them whenever there is anything you wish to know, such as the shunt signal. To explicitly assign the data, an identification number is attached on the rotor where it can be seen from outside (see Fig. 4.5).

1. Prior to installation, clean the measurement flange's and counter flanges' plane surfaces. For safe torque transfer, the surfaces must be clean and free from grease. Use a piece of cloth or paper soaked in solvent. When cleaning, make sure that you do not damage the transmitter coils.

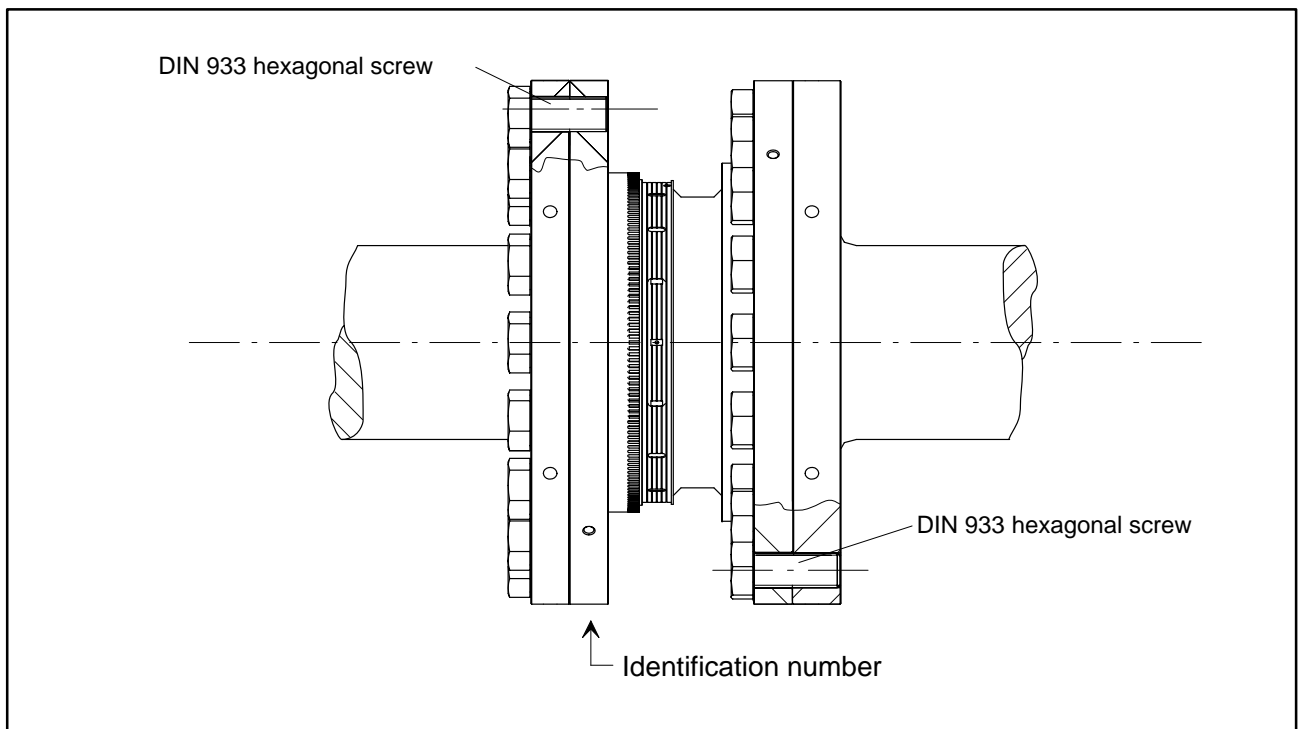

Fig. 4.5: Screwed rotor joint

2. For the screwed rotor joint, use DIN 933 hexagonal screws of property class 12.9 of an appropriate length (depending on the connection geometry)



WARNING

With alternating load: Use a screw locking device (e.g. LOCTITE no. 242) to cement the screws into the mating thread to exclude prestressing loss due to screw slackening.

3. Tighten all screws with the specified tightening torque (Tab. 4.1).
4. For further mounting of the shaft train, there are tapped holes on the rotor. Again use screws of property class 12.9 and tighten them crosswise with the prescribed tightening torque, as specified in Tab. 4.1.



CAUTION

With alternating loads, use a screw locking device to cement the connecting screws into place. Guard against contamination from varnish fragments.

Measuring range (kN·m)	Fastening screws ¹⁾	Fastening screws Property class	Number of screws per flange	Prescribed tightening torque (N·m)
100 130 150	M30	12.9	16	2450
200 250 300	M36		18	4250

Tab. 4.1: Fastening screws

¹⁾ DIN 933; black/oiled/ $\mu_{\text{tot}} = 0.125$



NOTE

We recommend that you use a hydraulic screwdriver to tighten the fastening screws!

4.6 Installing the stator

On delivery, the stator has already been fitted ready for operation. The antenna segments have to be separated for installation. To stop you modifying the center alignment of the segment rings opposite the base of the stator, we recommend that you separate only one antenna segment from the stator. Depending on the operating conditions, it may be necessary to stabilize the antenna ring with a clamp fixture (included among the components supplied). See page 23.

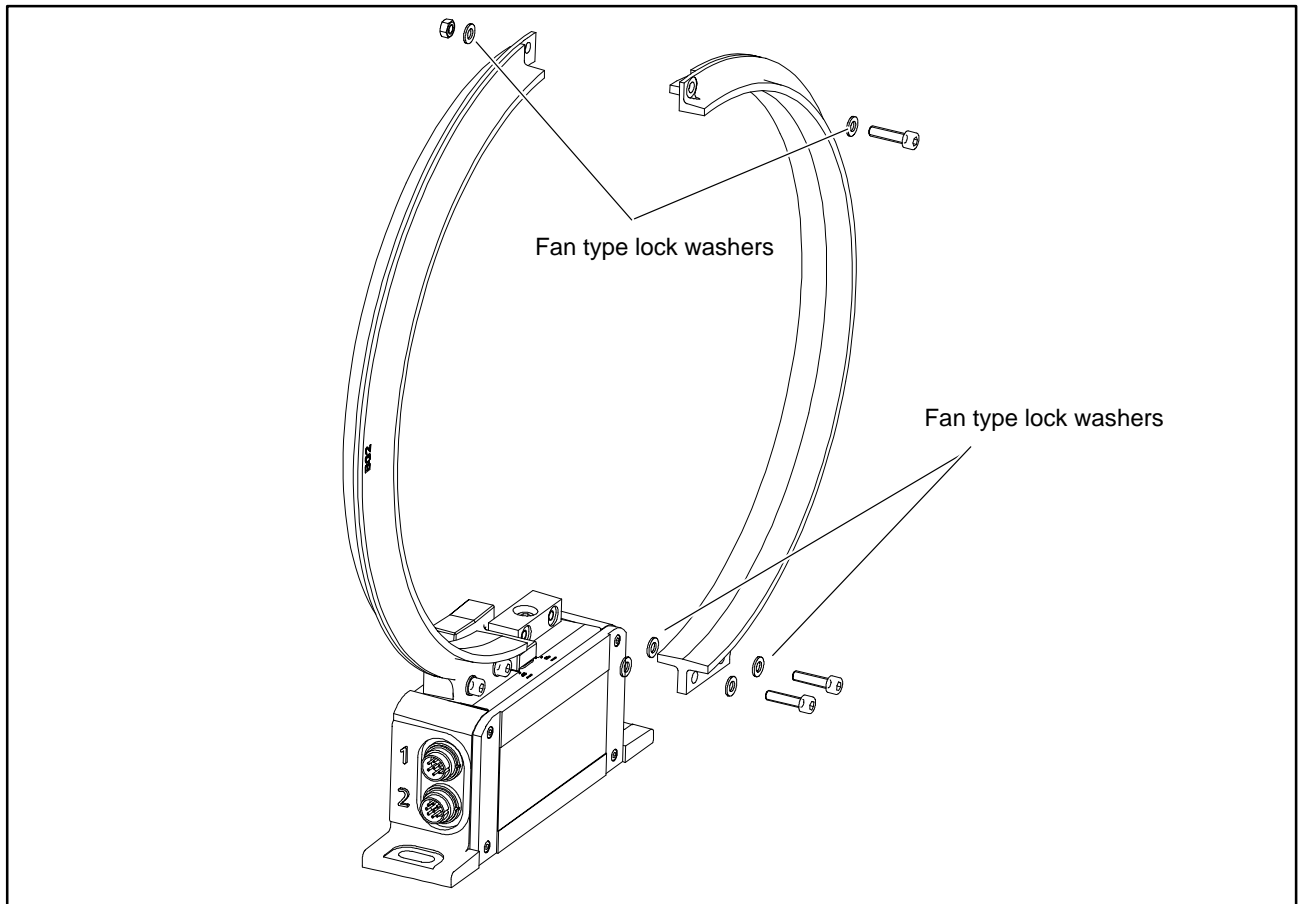

Fig. 4.6: Screw fittings of the antenna segments

1. Slacken and remove the screw fittings (M5) on one antenna segment. Make sure that the fan-type lock washers are not lost.
2. Place the antenna segments around the transmitter on the rotor and close the antenna ring again. Make sure that all the fan-type lock washers in front of **and** behind the antenna segment are present. If necessary, fit the clamp fixture at the same time (see page 23).
3. Use an appropriate base plate to install the stator housing in the shaft train so that there is sufficient possibility for horizontal and vertical adjustments. Do not yet fully tighten the screws.

4. Align the antenna and rotor so that the antenna encloses the rotor coaxially. Please observe the permissible alignment tolerances stated in the specifications.
5. Now fully tighten the screw fitting of the stator housing.
6. Make sure that the gap in the lower antenna segment area is free of electrically conductive foreign bodies.



CAUTION

To make sure that they function perfectly, the fan-type lock washers (A5.3-FST DIN 6798 ZN/galvanized) must be replaced after the antenna screw fastening has been loosened three times.

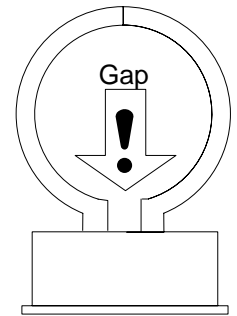

4.7 Installing the clamp fixture

Depending on the operating conditions, the antenna ring may be excited to vibrate. This effect is dependent on

- the speed
- the antenna diameter (depends in turn on the measuring range)
- the design of the machine base

To avoid vibrations, a clamp fixture is enclosed with the torque flange enabling the antenna ring to be supported.

Installation sequence

1. Loosen and remove the upper antenna ring screw fitting.
2. Fasten the clamp fixture with the enclosed screw fitting as shown in Fig. 4.7. It is essential to use the new fan-type lock washers.
3. Clamp a suitable support element (we recommend a threaded rod \varnothing 3 mm ... 6 mm) between the upper and lower parts of the clamp fixture and tighten the clamping screws.

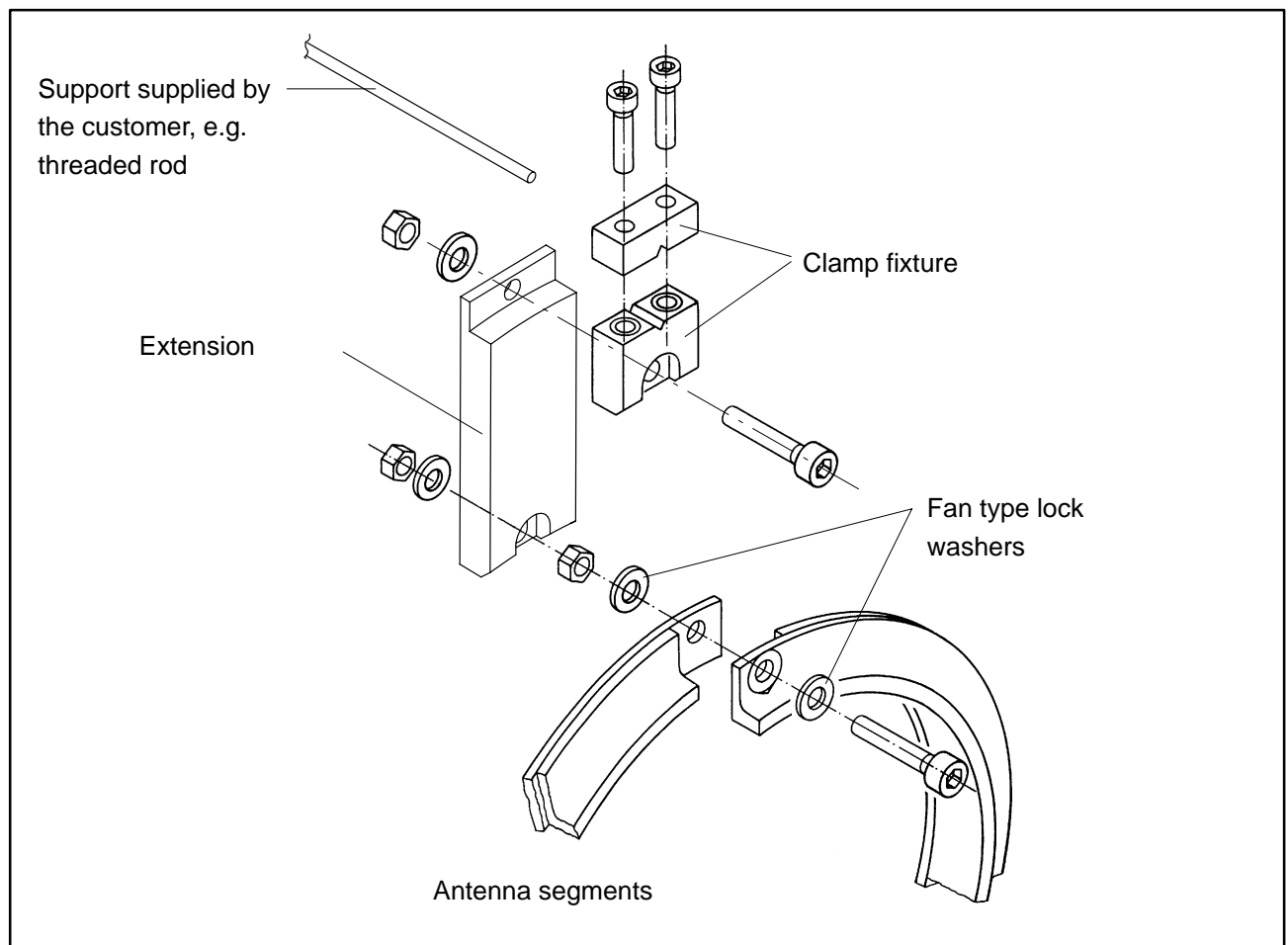

Fig. 4.7: Install the clamp fixture on the antenna ring

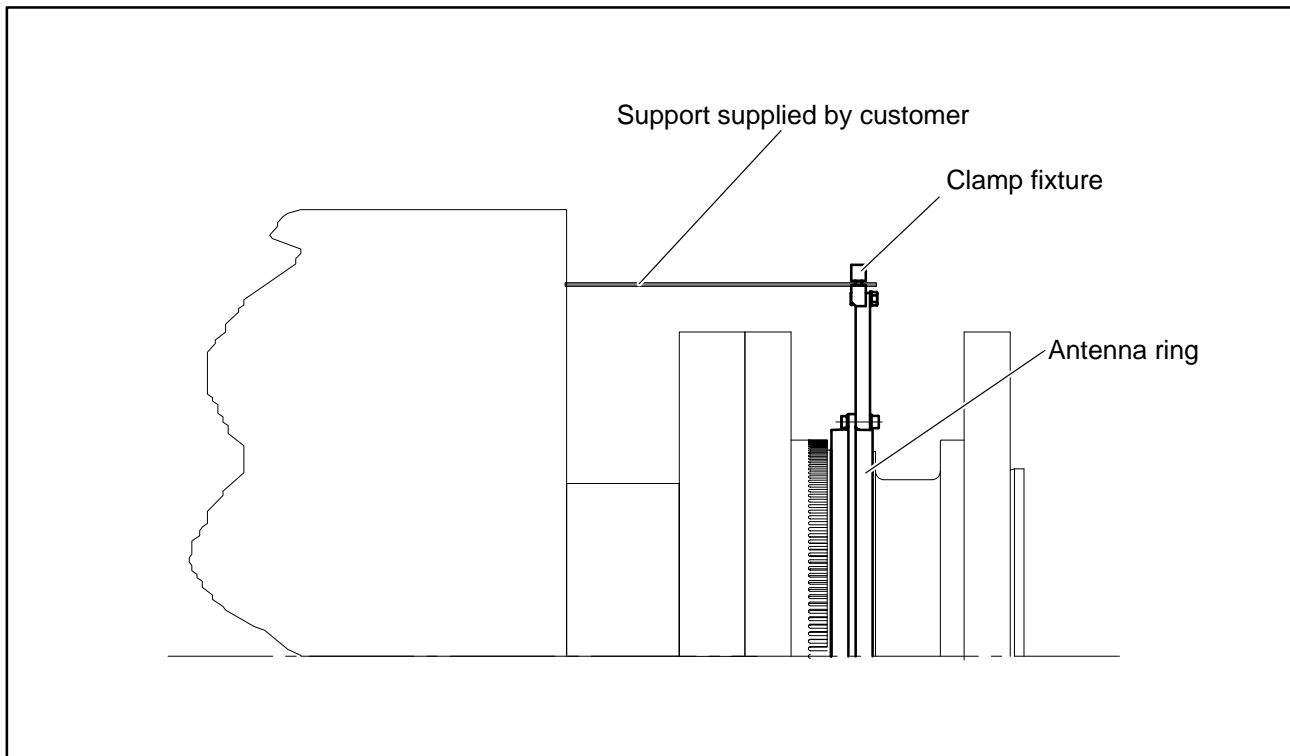

Fig. 4.8: Supporting the antenna ring

4.8 Aligning the stator (speed measuring system)

The stator can be mounted in any position (for example, "upside down" installation is possible).

For measuring mode to operate perfectly, the speed sensor must be placed at a defined position to the rotor ring gear.



NOTE

To fasten the stator, we recommend the use of M6 screws with plain washers (width of oblong hole, 9 mm). This size of screw guarantees the necessary travel for alignment.

Axial alignment

At the factory, the head of the speed measuring system sensor must be adjusted so that when the axial alignment of the stator is exact (antenna ring positioned precisely above the rotor winding carrier), the sensor is in the correct position to the ring gear.

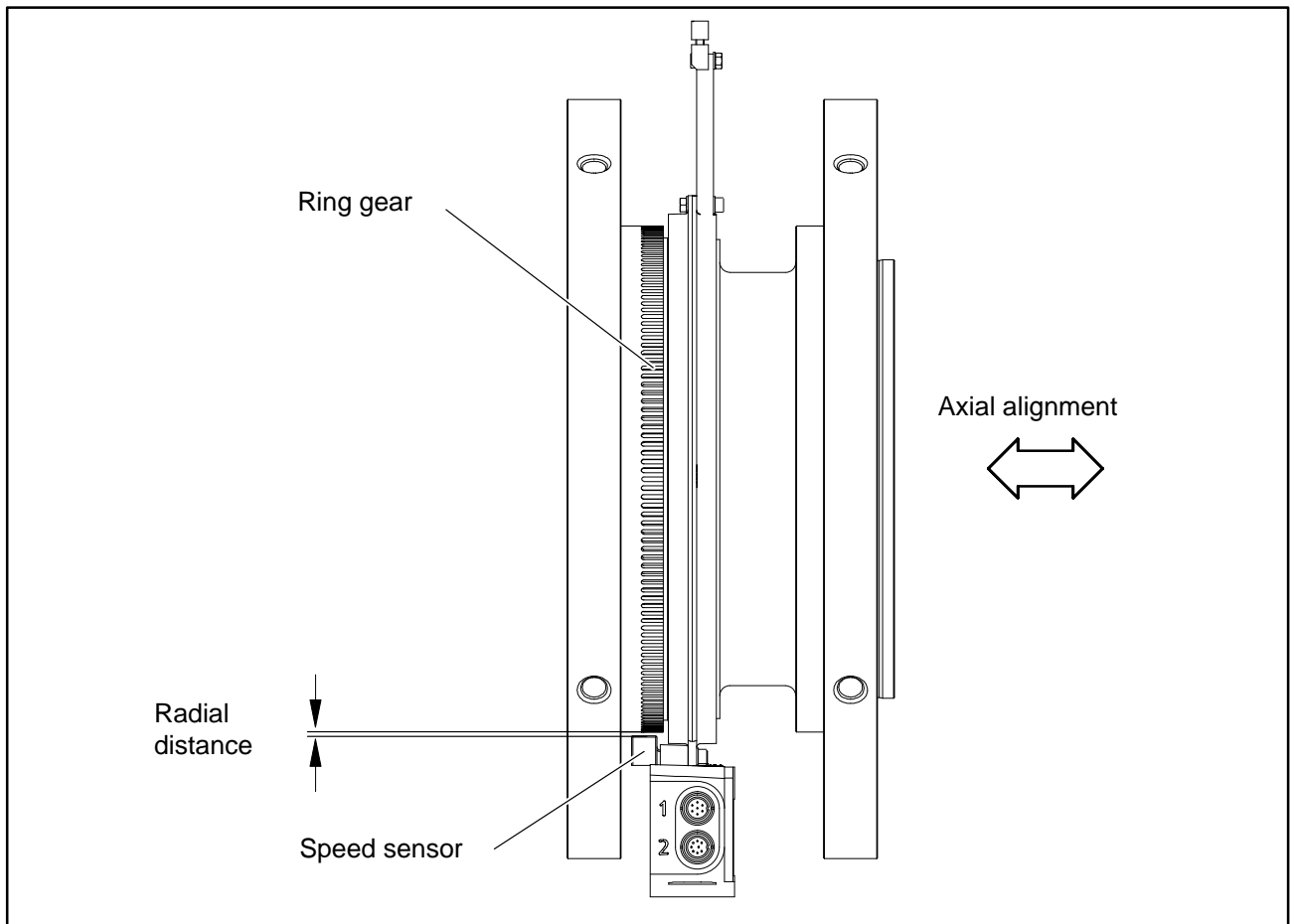

Fig. 4.9: Position of the sensor head to the ring gear

Radial alignment

The rotor axis and the axis of the speed sensor must be along a line at right angles to the stator platform. The radial distance is critical for the radial alignment (see Fig. 4.9). The optimum radial distance is 2.5 mm and is achieved when the rotor and the stator are in precise radial alignment.



NOTE

The mounting conditions are crucial for the pulse tolerance. Preferably try to keep to the specified nominal (rated) distance.

5 Electrical connection

5.1 General hints

To make the electrical connection between the torque flange and the amplifier, we recommend using shielded, low-capacitance measurement cables from HBM.

With cable extensions, make sure that there is a proper connection with minimum contact resistance and good insulation. All plug connections or swivel nuts must be fully tightened.

Do not route the measurement cables parallel to power lines and control circuits. If this cannot be avoided (in cable pits, for example), maintain a minimum distance of 50 cm and also draw the measurement cable into a steel tube.

Avoid transformers, motors, contactors, thyristor controls and similar stray-field sources.



CAUTION

Transducer connection cables from HBM with attached connectors are identified in accordance with their intended purpose (Md or n). When cables are shortened, inserted into cable ducts or installed in control cabinets, this identification can get lost or become concealed. If this is the case, it is essential for the cables to be re-labeled!

5.2 Shielding design

The cable shielding is connected in accordance with the Greenline concept. This encloses the measurement system (without a rotor) in a Faraday cage. It is important that the shield is laid flat on the housing ground at both ends of the cable. Any electromagnetic interference active here does not affect the measurement signal. Special electronic coding methods are used to protect the purely digital signal transmission between the transmitter head and the rotor from electromagnetic interference.

In the case of interference due to potential differences (compensating currents), operating voltage zero and housing ground must be disconnected on the amplifier and a potential equalization line established between the stator housing and the amplifier housing (copper conductor, 10mm² wire cross-section).





If potential differences arise between the rotor and the stator on the machine, perhaps due to unchecked leakage, and this causes interference, it can usu-

ally be overcome by connecting the rotor directly to ground, for instance by a wire loop. The stator should be fully grounded in the same way.

5.3 Connector pin assignment Option 3, Code SU2

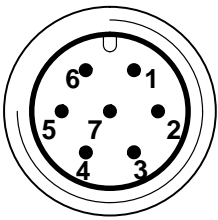
Assignment for connector 1:

Supply voltage and frequency output signal.

Binder 723	Connector Pin	Assignment	Color code	Sub-D connector Pin
 <p>Top view</p>	1	Torque measurement signal (frequency output; 5 V ¹⁾ ;  /0 V)	wh	13
	2	Supply voltage 0 V; 	bk	5
	3	Supply voltage 18 V ... 30 V	bu	6
	4	Torque measurement signal (frequency output; 5 V ¹⁾ /12 V)	rd	12
	5	Measurement signal 0 V;  symmetrical	gy	8
	6	Shunt signal resolution 5 V...30 V and for torque	gn	14
	7	Shunt signal 0 V; 	gy	8
		Shielding connected to enclosure ground		

¹⁾ Factory setting; complementary RS422 signals





CAUTION

Option 3, SU2 torque transducers are only intended for operation with a DC supply voltage (separated extra-low voltage). They must not be connected to older HBM amplifiers with square-wave excitation. This could lead to the destruction of the connection board, or other errors in the amplifiers (the torque flange, on the other hand, is protected and once the proper connections have been re-established, is ready for operation again).

Assignment for connector 2:

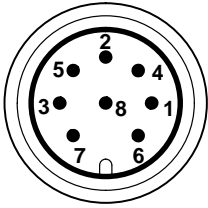



Speed measuring system

Binder 723	Connector Pin	Assignment	Color code	SubD connector Pin
 <p>Top view</p>	1	Speed measurement signal (pulse string, 5 V ¹⁾ ; 0°)	rd	12
	2	no function	–	–
	3	Speed measurement signal (pulse string, 5 V ¹⁾ ; 90° phase shifted) ²⁾	gy	15
	4	no function	–	–
	5	no function	–	–
	6	Speed measurement signal (pulse string, 5 V ¹⁾ ; 0°)	wh	13
	7	Speed measurement signal (pulse string, 5 V ¹⁾ ; 90° phase shifted)	gn	14
	8	Supply voltage zero 	bk	8
		Shielding connected to enclosure ground		

¹⁾ Complementary RS422 signals

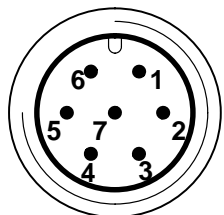
Assignment for connector 3:

Supply voltage and voltage output signal.

Binder 723	Connector Pin	Assignment
 <p>Top view</p>	1	Torque/speed measurement signal (voltage output; 0 V )
	2	Supply voltage 0 V; 
	3	Supply voltage 18 V to 30 V DC
	4	Torque measurement signal (voltage output; ± 10 V)
	5	no function
	6	Shunt signal resolution 5 V...30 V for torque
	7	Shunt signal 0 V; 
		Shielding connected to enclosure ground

5.4 Connector pin assignment Option 3, Code PNJ

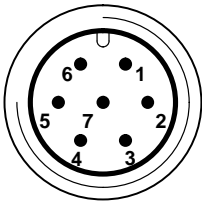
Binder 723  Top view	Con- nector Pin	Assignment	Color code
	1	Measurement signal (+) U_A	wh
	2	Excitation voltage (-) U_B and TEDS	bk
	3	Excitation voltage (+) U_B	bl
	4	Measurement signal (-) U_A	rd
	5	no function	-
	6	Sense lead (+)	gn
	7	Sense lead (-) and TEDS	gy
		Shielding connected to enclosure ground	

5.5 Supply voltage pin assignment (Option 3, Code SU2)

The transducer must be operated with a separated extra-low voltage (18...30 volts DC supply voltage), which usually supplies one or more consumers within a test bench. Should the equipment be operated on a dc voltage network¹⁾, additional precautions must be taken to discharge excess voltages.

5.5.1 Supply voltage for self-contained operation

The information in this section relate to the standalone operation of the T10FH without HBM system solutions.

Supply voltage is electrically isolated from signal outputs and shunt signal inputs. V) up to 50

Connect a separated extra-low voltage of 18 V...30 V to pin 3 (+) and pin 2 (⊖) of connectors 1 or 3. We recommend that you use HBM cable KAB 8/00-2/2/2 and the relevant Binder sockets, that at nominal (rated) voltage (24 V) can be up to 50 m long and in the nominal voltage range, 20 m long (see Accessories, page 55). If the permissible cable length is exceeded, you can supply the voltage in parallel over two connection cables (connectors 1 and 3). This enables you to double the permissible length. Alternatively an on-site power pack should be installed.

If you feed the supply voltage through an unshielded cable, the cable must be twisted (interference suppression). We also recommend that a ferrite element should be located close to the connector on the cable, and the stator should be grounded.

¹⁾ Distribution system for electrical energy with greater physical expansion (over several test benches, for example) that may possibly also supply consumers with high nominal (rated) currents.

**CAUTION**

The instant you switch on, a current of up to 2 A may flow and this may switch off power packs with electronic current limiters.

5.6 Supply voltage (Option 3, Code PNJ)

A ready-made 6-wire transducer connection cable with free ends can be requested as an accessory.

Extension cables should be shielded and of low capacitance. HBM provides specific cables for this purpose, the 1-KAB0304A-10 (ready-made) and the KAB8/00-2/2/2 (by the meter).

The pin assignment can be found in the table in section 5.4.

For the pin assignments at the amplifier end, please refer to the relevant amplifier documentation.

6 TEDS transducer identification (Option 3, Code PNJ)

TEDS stands for "Transducer Electronic Data Sheet". An electronic data sheet can be stored in the transducer as defined in the IEEE1451.4 standard, making it possible for the amplifier to be set up automatically. A suitably equipped amplifier reads out the transducer characteristics (electronic data sheet), translates them into its own settings and measurement can then start.

The digital identification system is available at plug connection PIN 7 to PIN 2. The HBM TEDS Editor is used to store the data. This is included in the HBM "MGCplus Setup Assistant" software. You can use the Editor to manage different user rights, thus protecting the essential transducer data from being overwritten by mistake.

6.1 Hierarchy of user rights

6.1.1 Standard rights (USR level)

This level concerns rights which the user of the transducer needs in order to change the entries which depend on the conditions of use.

6.1.2 Calibration rights (CAL level)

This level concerns the rights needed by a calibration laboratory, for example, if the sensitivity in the TEDS memory is to be changed.

6.1.3 Administrator rights (ID level)

Administrator rights in relation to TEDS are intended for the sensor manufacturer.

Different user rights are needed in order to amend the various entries in the templates, and these rights may differ from one entry to the next within a template.

6.2 Content of the TEDS memory as defined in IEEE 1451.4

The information in the TEDS memory is organized into areas, which are prestructured to store defined groups of data in table form.

Only the entered values are stored in the TEDS memory itself. The amplifier firmware assigns the interpretation of the respective numerical values. This places a very low demand on the TEDS memory. The memory content is divided into three areas:

Area 1:

An internationally unique TEDS identification number (cannot be changed).

Area 2:

The base area (basic TEDS), to the configuration defined in standard IEEE1451.4. The transducer type, the manufacturer and the transducer serial number are contained here.

Example:

TEDS content with the identity number for the T10FH/150 kN · m sensor with serial no. 123456, made in November 2005

TEDS	
Manufacturer	HBM
Model	T10FH
Version letter	
Version number	
Serial number	123456

Area 3:

Data specified by the manufacturer and the user are contained in this area:
For the T10FH torque flange, HBM has already described the **Bridge Sensor** and **Channel name** templates.

Additional templates, such as the **Signal Conditioning** template, can also be described by the user.

Template: Bridge Sensor				
Parameter	Value ¹⁾	Unit	Required user rights	Explanation
Transducer Electrical Signal Type	Bridge Sensor		ID	
Minimum Torque	0.000	N · m	CAL	The physical measured quantity and unit are defined when the template is created, after which they cannot be changed.
Maximum Torque	150000	N · m	CAL	
Minimum Electrical Value	0.0000m	V/V	CAL	The difference between these values is the sensitivity according to the HBM test certificate or from the calibration.
Maximum Electrical Value	1.8245m	V/V	CAL	
Mapping Method	Linear			This entry cannot be changed
Bridge type	Full		ID	The bridge type. "Full" for a full bridge.
Impedance of each bridge element	1550+–100	Ohm	ID	Input resistance according to the HBM data sheet.
Response Time	1.0000000u	s	ID	Of no significance for HBM transducers
Excitation Level (Nominal)	5.0	V	ID	Nominal (rated) excitation voltage according to the HBM data sheet
Excitation Level (Minimum)	2.5	V	ID	Lower limit for the operating range of the excitation voltage according to the HBM data sheet
Excitation Level (Maximum)	12.0	V	ID	Upper limit for the operating range of the excitation voltage according to the HBM data sheet

¹⁾ Typical values for an HBM T10FH/150 kN · m torque flange

Parameter	Value ¹⁾	Unit	Required user rights	Explanation
Calibration Date	1–Nov–2005	CAL		Date of the last calibration or creation of the test certificate (if no calibration carried out), or of the storage of the TEDS data (if only nominal (rated) values from the data sheet were used). Format: day–month–year. Abbreviations for the months: Jan, Feb, Mar, Apr, May, Jun, Jul, Aug, Sep, Oct, Nov, Dec.
Calibration Initials	HBM		CAL	Initials of the calibrator or calibration laboratory concerned.
Calibration Period (Days)	730	days	CAL	Time before recalibration, calculated from the date specified under Calibration Date.
Measurement location ID	0		USR	Identification number for the measuring point. Can be assigned according to the application. Possible values: a number from 0 to 2047. If that is not enough, the HBM Channel Comment template can also be used for this purpose.

¹⁾ Typical values for an HBM T10FH/150 kN · m torque flange

Template: HBM Channel Name	
Channel name	T10FH/150 kNm

When the manufacturer creates the **Bridge Sensor** template, the physical measured quantity and the physical unit are defined.

The available unit for the particular measured quantity is specified in the IEEE Standard. For the measured quantity of torque, the unit is "N · m".

Also in the template, the choice has to be made between "Full precision", "mV/V" and "uV/V" for the accuracy of the characteristic curve of the transducer mapped in TEDS.

The factory setting is "Full Precision", in order to be able to use full digital resolution. This choice is also recommended to users who program the TEDS memory themselves.

7 Shunt signal (Option 3, Code SU2)

The T10FH torque flange delivers a shunt signal that can be switched at the amplifier end for measurement chains with HBM components. The measurement flange generates a shunt signal of about 50% of the nominal (rated) torque. The precise value is specified on the identification plate. Adjust the amplifier output signal to the shunt signal supplied by the connected torque flange to adapt the amplifier to the measurement flange. To obtain stable conditions, the shunt signal should only be activated once the transducer has been warming up for 15 minutes.



NOTE

The transducer should not be under load when the shunt signal is being measured, as the signal is applied additively.



CAUTION

To maintain measurement accuracy, the shunt signal should be connected for no more than 5 minutes. A similar period is then needed as a cooling phase before triggering the shunt signal again.

7.1 Shunt signal

Applying a separated extra-low voltage of 5 V to pin 6 (+) and 7 () on plug 1 or 3 triggers the calibration signal.

The nominal (rated) voltage for triggering the shunt signal is 5V (triggered when $U > 2.7$ V). The trigger voltage is electrically isolated from the supply voltage and the measurement voltage. The maximum permissible voltage is 30 V. When voltages are less than 0.7 V, the torque flange is in measuring mode. Current consumption at nominal (rated) voltage is approx. 2 mA and at maximum voltage is approx. 22 mA.



NOTE

In the case of HBM system solutions, the amplifier triggers the shunt signal.

8 Settings (Option 3, Code SU2)

8.1 Torque output signal

The factory setting for the frequency output voltage is 5 V (symmetrical, complementary RS422 signals). The frequency signal is on pin 4 opposite pin 1. You can change the output voltage to 12 V (asymmetrical). To do this, change switches S1 and S2 to position 1 (and pin 1 → .

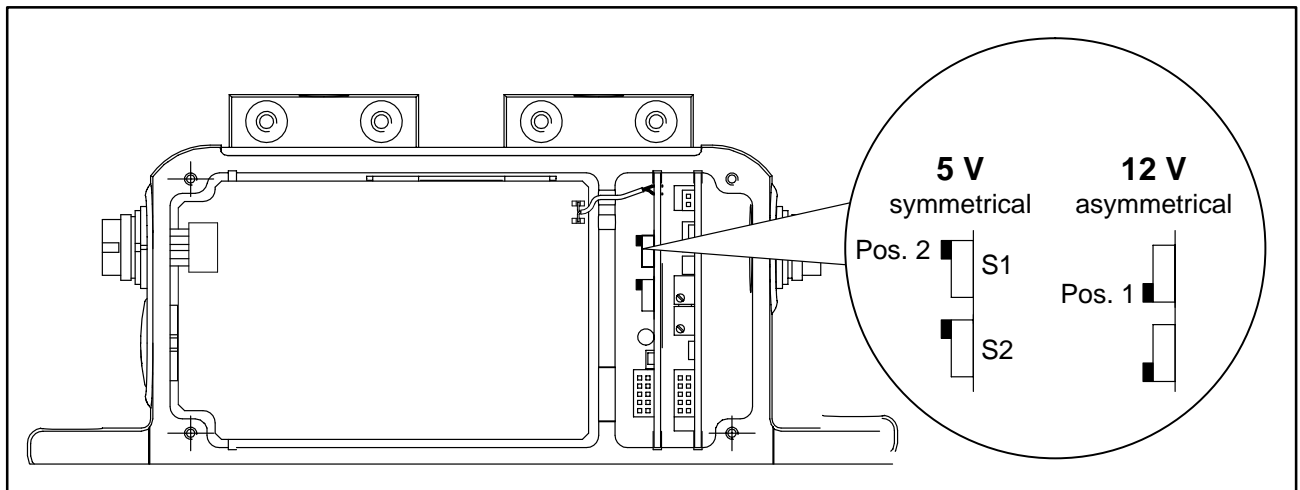

Fig. 8.1: Switch for changing the frequency output voltage

8.2 Setting up the zero point

In the case of the torque flange with the voltage output option (SU2), you can access two potentiometers by removing the stator cover. You can use the zero point potentiometer to correct certain zero point deviations. The adjustment range is a minimum of ± 400 mV at nominal (rated) amplification. The end point potentiometer is used for adjustment at the factory and is capped with varnish so that it cannot be turned unintentionally.



CAUTION

Turning the end point potentiometer changes the factory calibration of the voltage output.

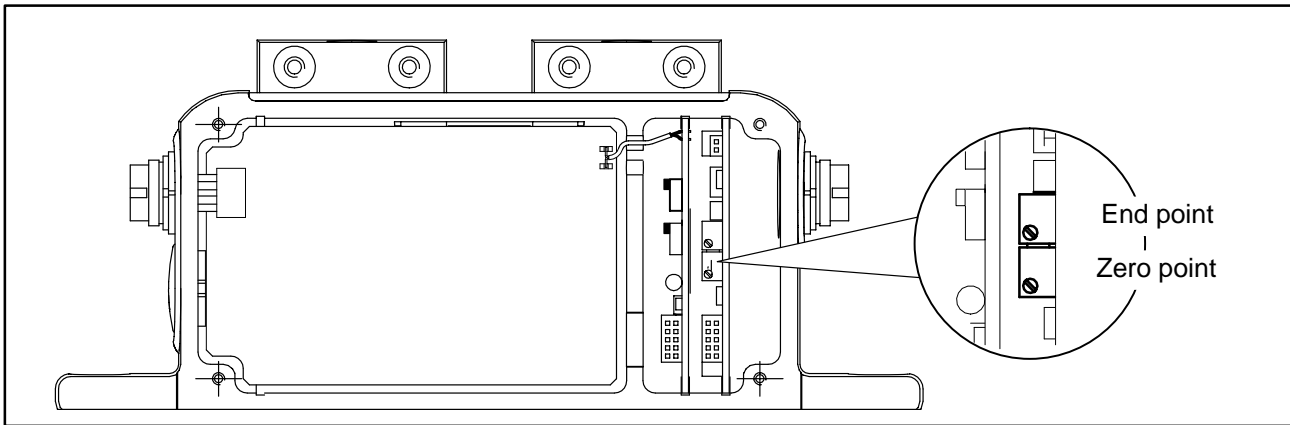

Fig. 8.2: Setting the voltage output zero point

8.3 Function testing

8.3.1 Power transmission

If you suspect that the transmission system is not working properly, you can remove the stator cover and test for correct functioning. If the LED is on, the rotor and stator are properly aligned and there is no interference with the transmission of measurement signals. When the shunt signal is triggered, the LED shines more brightly.

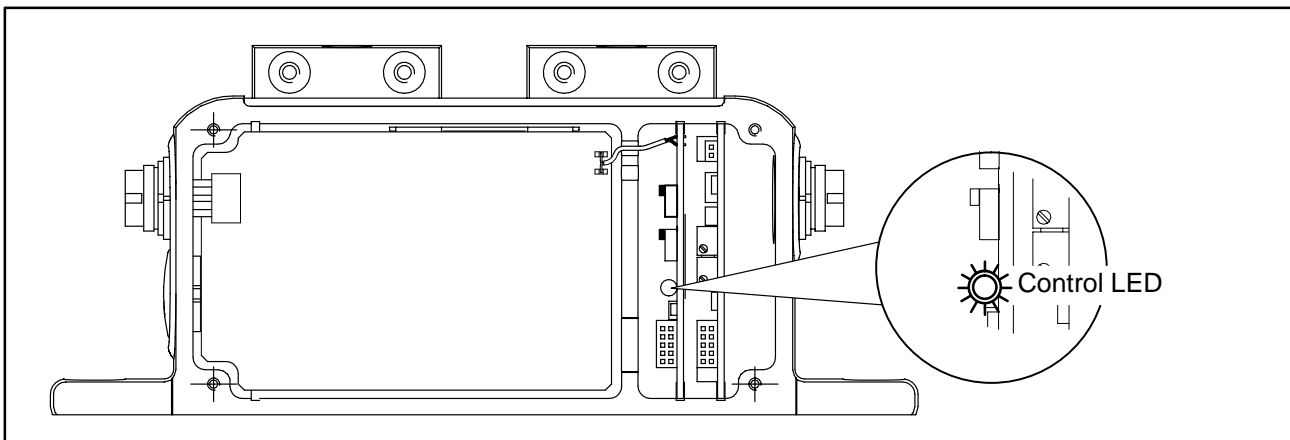

Fig. 8.3: Power transmission function test

8.3.2 Checking the speed measuring system

If required, you can check that the speed measuring system is functioning correctly.

1. Remove the cover of the stator housing.
2. Turn the rotor by at least 2 min^{-1} .

If both the control LEDs come on while you are turning the rotor, the speed measuring system is properly aligned and fully operational.

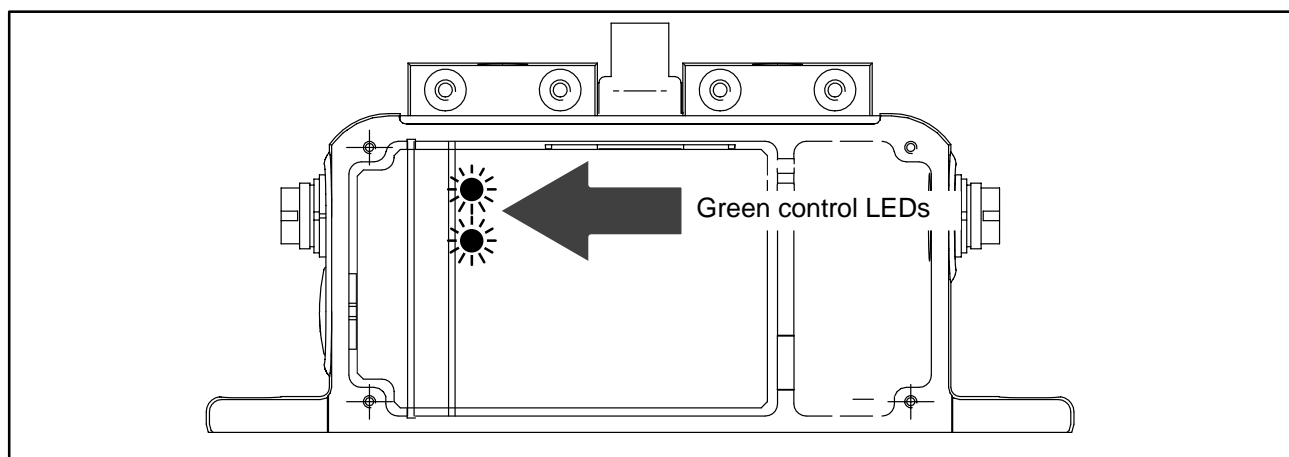

Fig. 8.4: Speed measuring system control LEDs



ATTENTION

When closing the cover of the stator housing, make sure that the internal connection cables are positioned in the grooves provided and are not caught up.

8.4 Speed measuring system

For optimum functionality, all the DIP-switches (S1–S6) for the speed measuring system must be in the "OFF" position (factory setting).

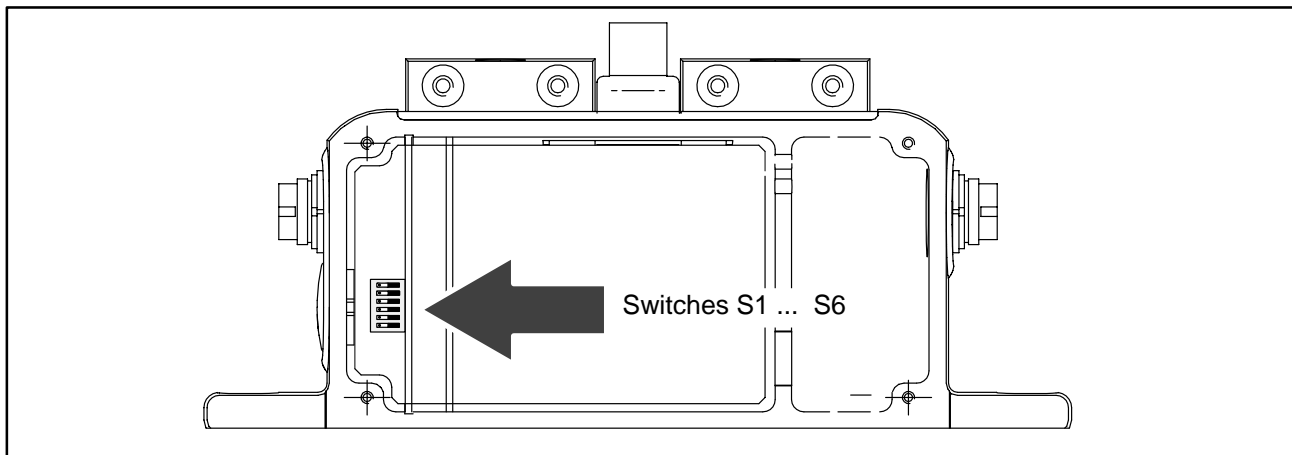

Fig. 8.5: Switches for setting the speed measuring system

8.5 Form of speed output signal

In the factory setting, two 90° phase-offset speed signals (5 V symmetrical, complementary RS422 signals) are available at the speed output (connector 2).

8.6 Type of speed output signal

You can use switch S7 to change the symmetrical 5 V output signal (factory setting) to an asymmetrical signal of 0 V ... 5 V.

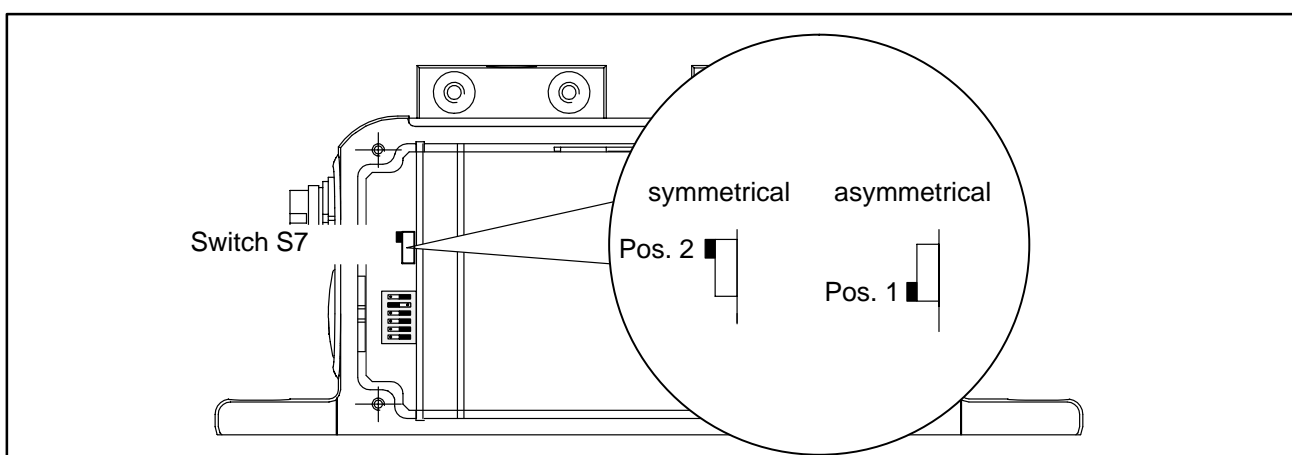

Fig. 8.6: Switch S7; symmetrical/asymmetrical output signal

9 Loading capacity

Nominal (rated) torque can be exceeded statically up to the limit torque. If the nominal torque is exceeded, additional irregular loading is not permissible. This includes longitudinal forces, lateral forces and bending moments. Limit values can be found in the "Specifications" section, on page 41.

9.1 Measuring dynamic torque

The torque transducer is suitable for measuring static and dynamic torques. The following applies to the measurement of dynamic torque:

- The T10FH calibration performed for static measurements is also valid for dynamic torque measurements.
- The natural frequency f_0 of the mechanical measuring arrangement depends on the moments of inertia J_1 and J_2 of the connected rotating masses and the torsional stiffness of the T10FH.

Use the equation below to approximately determine the natural frequency f_0 of the mechanical measuring arrangement:

$$f_0 = \frac{1}{2\pi} \cdot \sqrt{c_T \cdot \left(\frac{1}{J_1} + \frac{1}{J_2} \right)}$$

f_0 = natural frequency in Hz
 J_1, J_2 = mass moment of inertia in $\text{kg}\cdot\text{m}^2$
 c_T = torsional stiffness in $\text{N}\cdot\text{m}/\text{rad}$

- The mechanical vibration bandwidth must not exceed the values stated in the specifications (see "Specifications", starting on page 41). The vibration bandwidth must fall within the load range designated by the upper and lower maximum torques. The same also applies to transient resonance points.

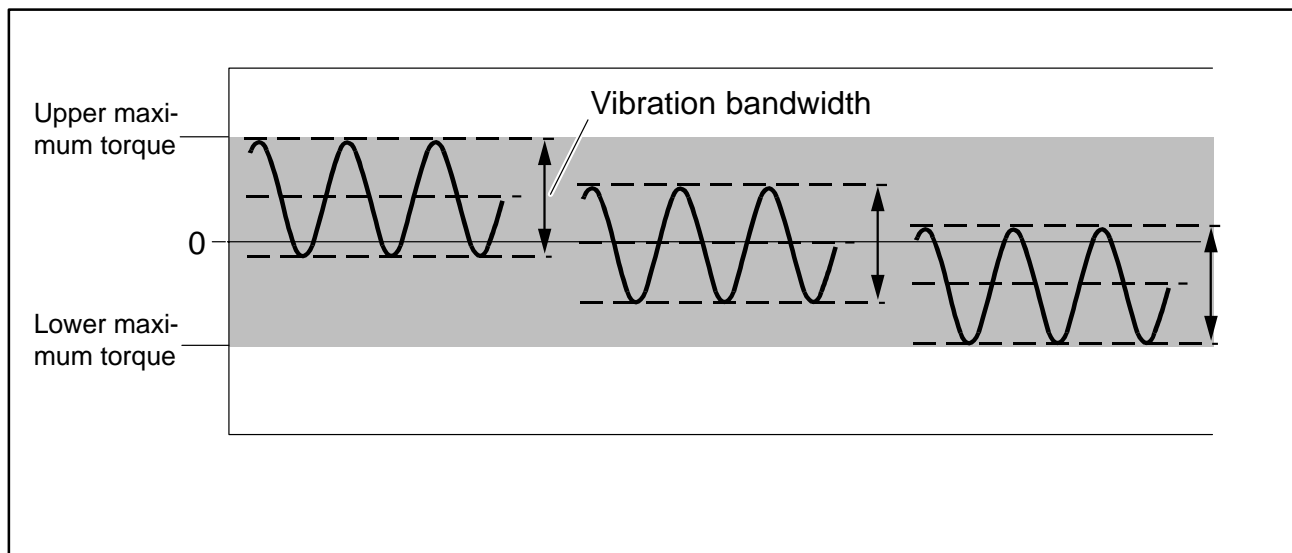

Fig. 9.1: Permissible dynamic loading

10 Maintenance

The T10FH torque flange is maintenance free.

11 Specifications

Type		T10FH (rotating); option 2, code L					
Accuracy class		0.1					
Torque measuring system							
Nominal (rated) torque M_{nom} for reference only	kN·m kft·lb	100 73.8	130 95.9	150 110.6	200 147.5	250 184.4	300 221.3
Nominal (rated) sensitivity (range between torque = zero and nominal (rated) torque) Frequency output Voltage output Sensitivity tolerance (deviation of the actual output value at M_{nom} of nominal (rated) sensitivity) Frequency output in conjunction with HBM test report in conjunction with DKD calibration certificate per DIN 51309 or EA-10/14 Voltage output in conjunction with HBM test report in conjunction with DKD calibration certificate per DIN 51309 or EA-10/14	kHz	5					
	V	± 10					
	%	± 0.25		± 0.4			
	%	± 0.1		± 0.1			
	%	± 0.35		± 0.5			
	%	± 0.2		± 0.2			
Output signal at torque = zero Frequency output Voltage output	kHz V	10 0					
Nominal (rated) output signal Frequency output with positive nominal (rated) torque with negative nominal (rated) torque	kHz	15 (± 5 V symmetric) ¹⁾ / 15 (12 V asymmetric)					
	kHz	5 (± 5 V symmetric) ¹⁾ / 5 (12 V asymmetric)					
Voltage output with positive nominal (rated) torque with negative nominal (rated) torque	V	+10					
	V	-10					
Load resistance Frequency output Voltage output	kΩ	> 2					
	kΩ	> 5					
Long-term drift over 48 h Voltage output	mV	± 3					
Measurement frequency range Voltage output	Hz	0 ... 1000 (-3 dB)					
Group delay time Frequency output Voltage output	ms	0.15					
	ms	0.9					

¹⁾ RS 422 complementary signals; factory settings

Type		T10FH (rotating); option 2, code L
Speed measuring system		
Measuring system		Magnetic field dependent resistor and gear ring
Mechanical increments (pulses per revolution)	Number	180
Output signal	V	5 symmetric ³⁾ ; 2 x 180 square wave signals approx. 90° phase shifted
Minimum speed for sufficient pulse stability	rpm	> 2
Load resistance	kΩ	> 5
Group delay time	μs	< 5
Hysteresis of reversing the direction of rotation with relative vibrations between rotor and stator Torsional rotor vibrations	degree	10
Max. permissible static eccentricity of the rotor (radially) relative to stator center without speed measuring system with speed measuring system	mm mm	± 2 ± 1
Max. permissible axial displacement between rotor and stator without speed measuring system with speed measuring system	mm mm	± 3 ± 1.5

³⁾ RS 422 complementary signals

Type		T10FH (non-rotating); option 2, code N					
Accuracy class		0.1					
Torque measuring system							
Nominal (rated) torque M_{nom} for reference only	kN·m	100	130	150	200	250	300
	kft·lb	73.8	95.9	110.6	147.5	184.4	221.3
Nominal (rated) sensitivity at M_{nom} (nominal (rated) signal range between torque= zero and nominal (rated) torque) Sensitivity tolerance (deviation of the actual output value at M_{nom} of nominal (rated) sensitivity) in conjunction with HBM test report in conjunction with DKD calibration certificate per DIN 51309 or EA-10/14	mV/V	1.1 ... 1.9 (The sensitivity is specified on the identification plate)					
	%	± 0.25			± 0.4		
	%	± 0.1			± 0.1		
Temperature influence per 10 K in the nominal temperature range on the output signal, related to the actual value of signal span on the zero signal, related to the nom. sensitivity	%	± 0.1					
	%	± 0.05					
Linearity deviation including hysteresis, related to the nominal (rated) sensitivity	%	± 0.1					
Rel. standard deviation of the reproducibility, per DIN 1319, relative to variation of the output signal	%	± 0.02					
Input resistance at reference temperature	Ω	1550 ± 100					
Output resistance at reference temperature	Ω	1300 ... 1500					
Reference excitation voltage	V	5					
Operating range of the excitation voltage	V	2.5 ... 12					
Transducer identification	–	TEDS per IEEE 1451.4					

General data							
Nominal (rated) torque M_{nom} for reference only	kN·m kft·lb	100 73.8	130 95.9	150 110.6	200 147.5	250 184.4	300 221.3
EMC EME (Emission per EN61326-1, table 4) RFI field strength	-	Class B					
Immunity from interference (EN61326-1, table A.1) Electromagnetic field AM Magnetic field ESD Contact discharge Air discharge Burst Surge Line-conducted disturbance (AM)	V/m A/m kV kV kV kV V	10 30 4 8 1 1 3					
Degree of protection per EN 60529	-	IP 54					
Nominal temperature range	°C [°F]	+10...+60 [+50...+140]					
Reference temperature	°C [°F]	+23 [73.4]					
Service temperature range	°C [°F]	+10...+60 [+50...+140]					
Storage temperature range	°C [°F]	-20...+70 [-4...+158]					
Mechanical shock ; test severity level to DIN IEC 60068-2-27; IEC 68-2-29-1987 Number of impacts Duration Acceleration	n ms m/s ²	1000 3 650					
Vibrational stress ; test severity level to DIN IEC 60068-2-6; IEC 68-2-6-1982 Frequency range Duration Acceleration	Hz h m/s ²	5 ... 65 1.5 50					
Nominal (rated) speed^{*)}	rpm	3000			2000		

^{*)} Only with option 2, code L

Nominal (rated) torque M_{nom} for reference only	kN·m kft·lb	100 73.8	130 95.9	150 110.6	200 147.5	250 184.4	300 221.3
Load limits ⁴⁾							
Limit torque	kN·m		200			400	
Breaking torque	kN·m		> 300			> 600	
Axial limit force	kN		230			290	
Lateral force limit	kN		110			240	
Bending limit moment	kN·m		22			35	
Oscillation bandwidth per DIN 50100 (peak-to-peak)	kN·m		200			400	
upper maximum torque	kN·m		+150			+300	
lower maximum torque	kN·m		-150			-300	

⁴⁾ Each type of irregular stress can only be permitted with its given static load limit (bending moment, lateral or axial load, exceeding the nominal (rated) torque) if none of the others can occur. Otherwise the limit values must be reduced. If for instance 30 % of the bending limit moment and also 30 % of the lateral limit force are present, only 40 % of the axial limit force are permitted, provided that the nominal (rated) torque is not exceeded. With the permitted bending moments, axial, and lateral limit forces, measuring errors of about 1 % of the nominal (rated) torque can occur. If the nominal (rated) torque is exceeded, ensure that the maximum modulation range of the signal output electronics is being observed.

Mechanical values							
Nominal (rated) torque M_{nom} for reference only	kN·m kft·lb	100 73.8	130 95.9	150 110.6	200 147.5	250 184.4	300 221.3
Torsional stiffness c_T	kN·m/rad	84000			169500		
Axial stiffness c_a	kN/mm	1250			2850		
Radial stiffness c_r	kN/mm	2500			4300		
Stiffness with bending moment about a radial axis c_b	kN·m/rad	17500			49600		
Maximum deflection at axial limit force	mm	< 0.5					
Additional max. concentricity error at lateral limit force	mm	< 0.1					
Additional plane-parallel deviation at bending limit moment	mm	< 1					
Balance quality-level to DIN ISO 1940⁵⁾		G 6.3					
Max. limits for relative shaft vibration (peak-to-peak)⁵⁾⁶⁾	μm	$s_{max} = \frac{4500}{\sqrt{n}}$ (n in rpm)					
Mass moment of inertia of the rotor L_v (about axis of rotation)	kg·m ²	2			5.2		
Proportional mass moment of inertia for transmitter side, approx.	%	55			53		
Weight, approx.							
Rotor	kg	84			148		
Stator ⁵⁾	kg	1.4					
Supplementary information per DIN 51309							
Class per DIN 51309		0.5					
Rel. zero error (zero signal return)	%	< ±0.125 (typically < 0.05)					
Rel. spread (0.1 · M_{nom} to M_{nom}) with							
unmodified mounting position	%	< 0.25 (typically < 0.125)					
with modified mounting position	%	< 0.5 (typically < 0.25)					
Relative reversibility error (0.1 · M_{nom} to M_{nom})	%	< 0.63 (typically < 0.5)					

5) Rotating; option 2, code L

6) Relative undulation in the area of the connection flanges per DIN 45670/VDI 2059

13 Dimensions Rotor T10FH non-rotating; option 2, code N

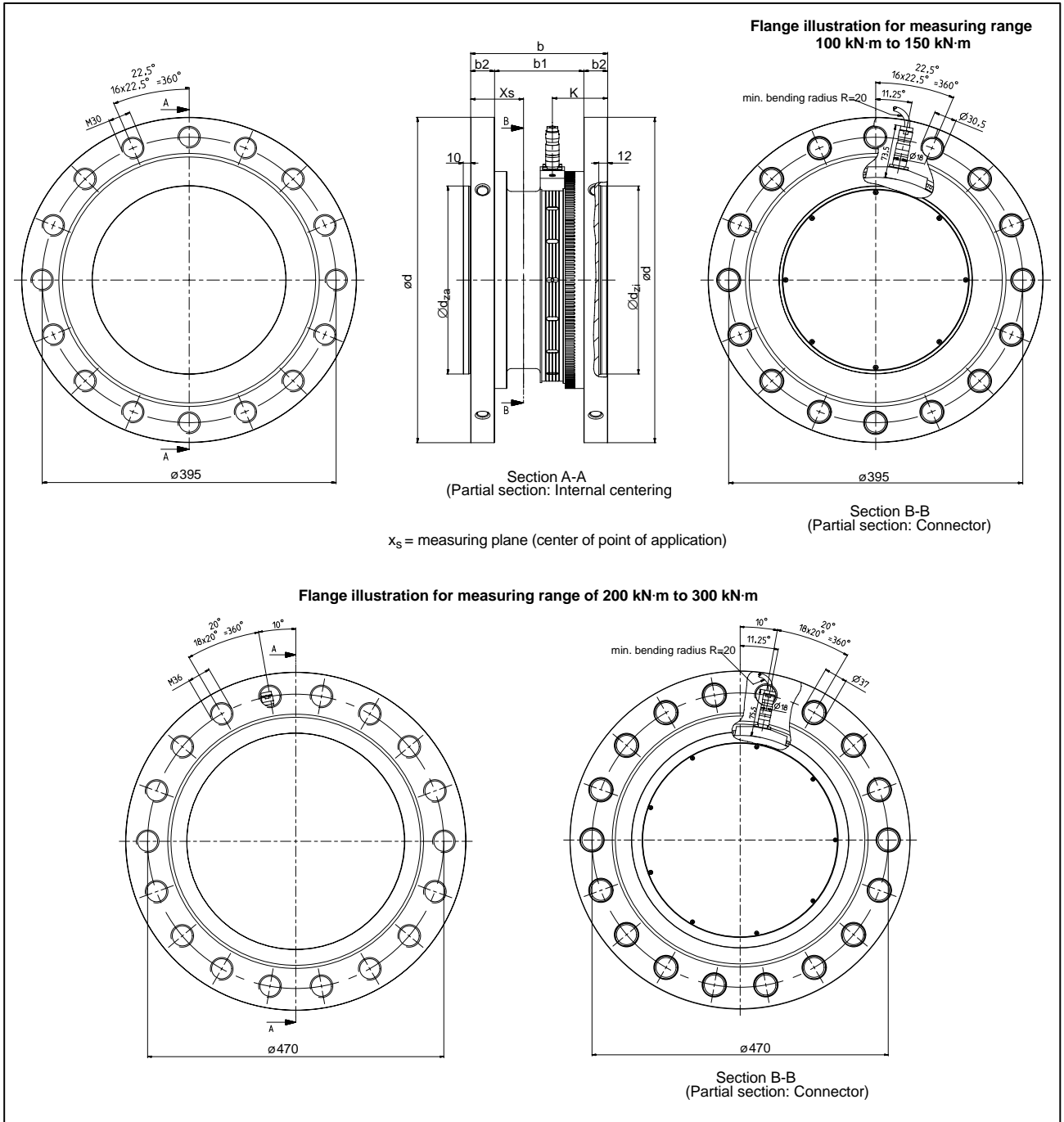

Measuring range (kN·m)	Dimensions in mm							
	b	b1	b2	Ød	Ød _{zah6}	Ød _{zi} ^{H7}	K	x _S
100								
130	184	120	32	450	260	260	74.3	71
150								
200								
250	230	150	40	540	345	345	90	98
300								

14 Mounting Dimensions

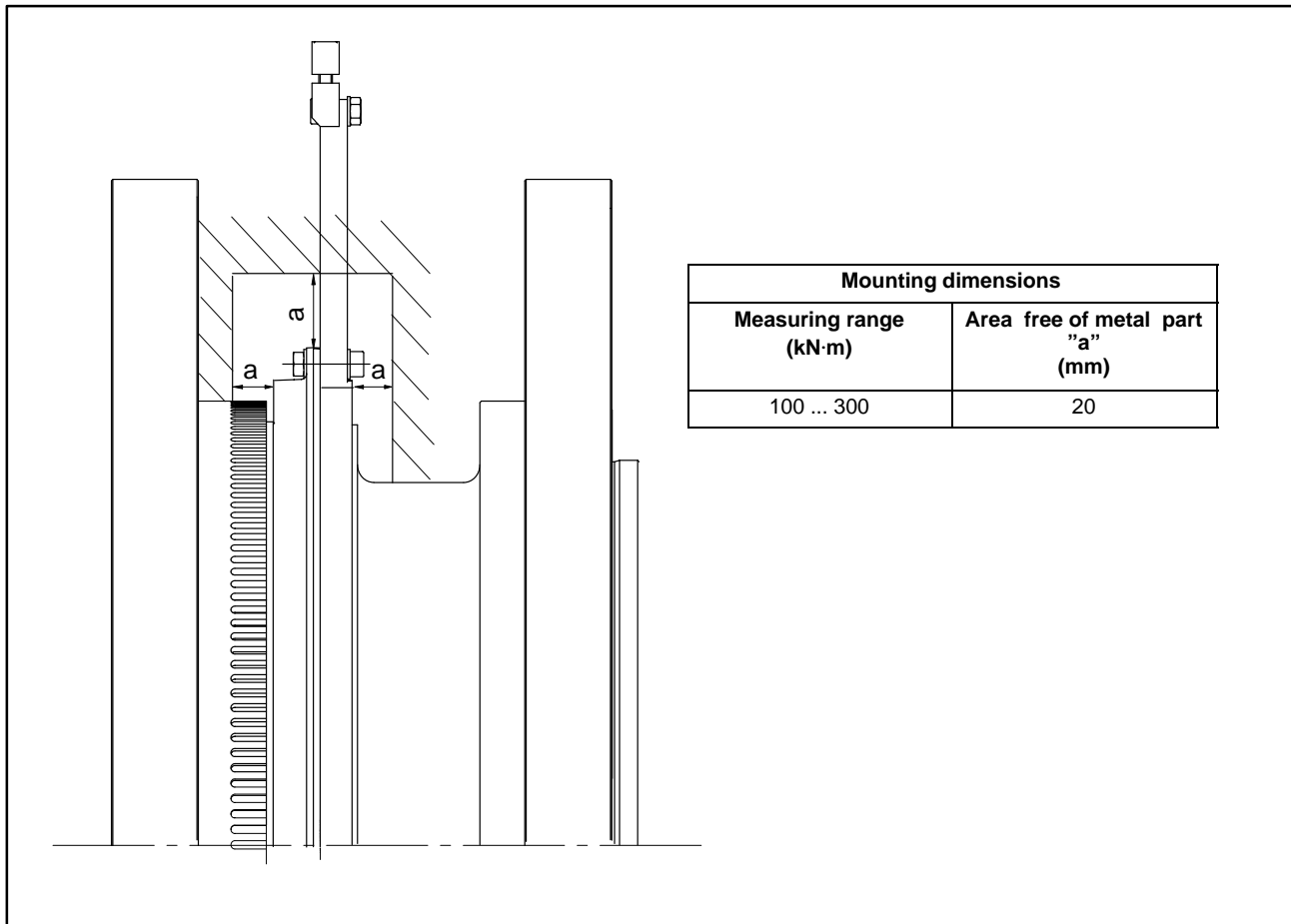

15 Supplementary technical information; option 2, code L

15.1 Output signals

15.1.1 Output MD for torque (connector 1)

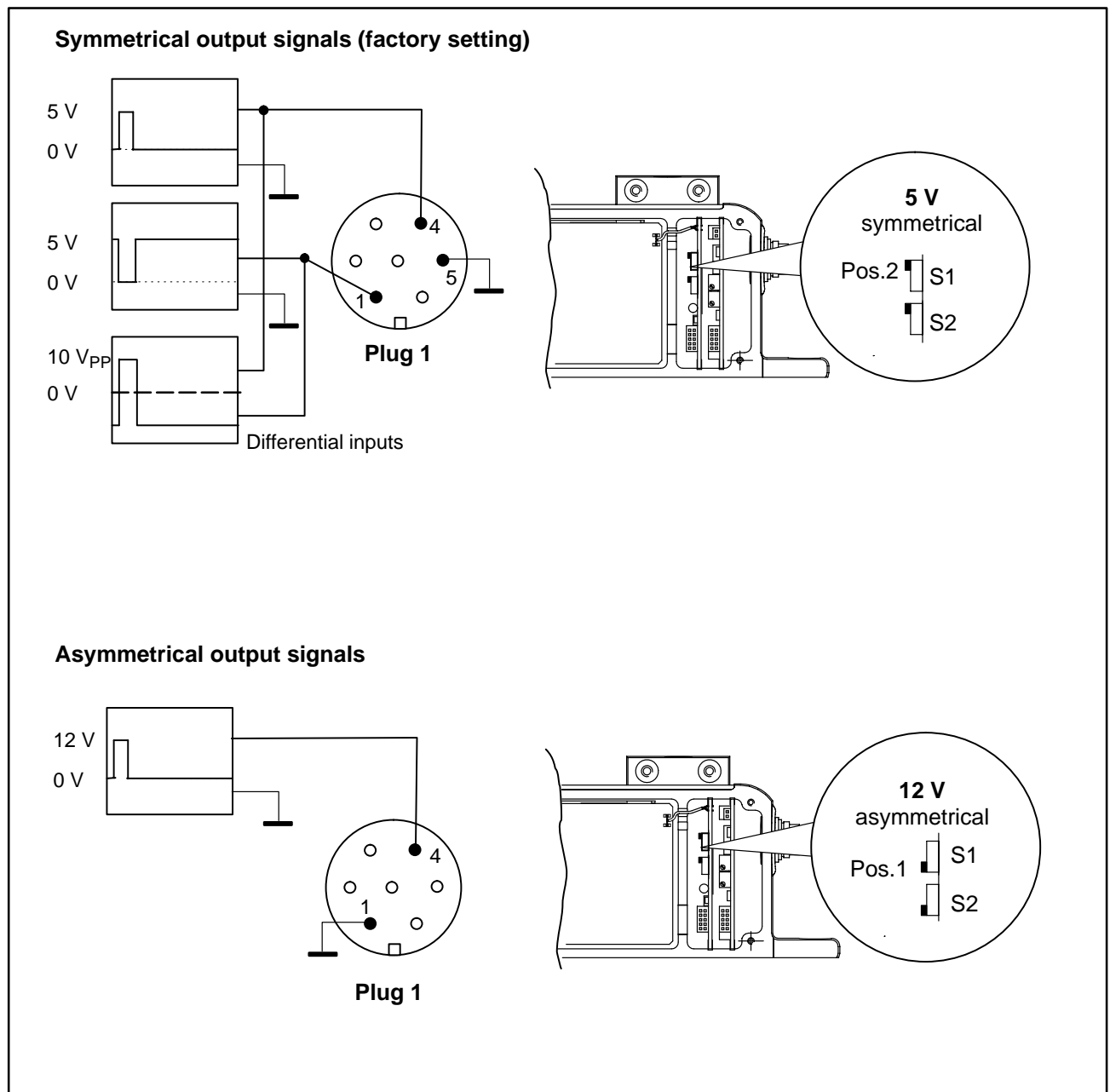

15.1.2 Output N for rotation speed (connector 2)

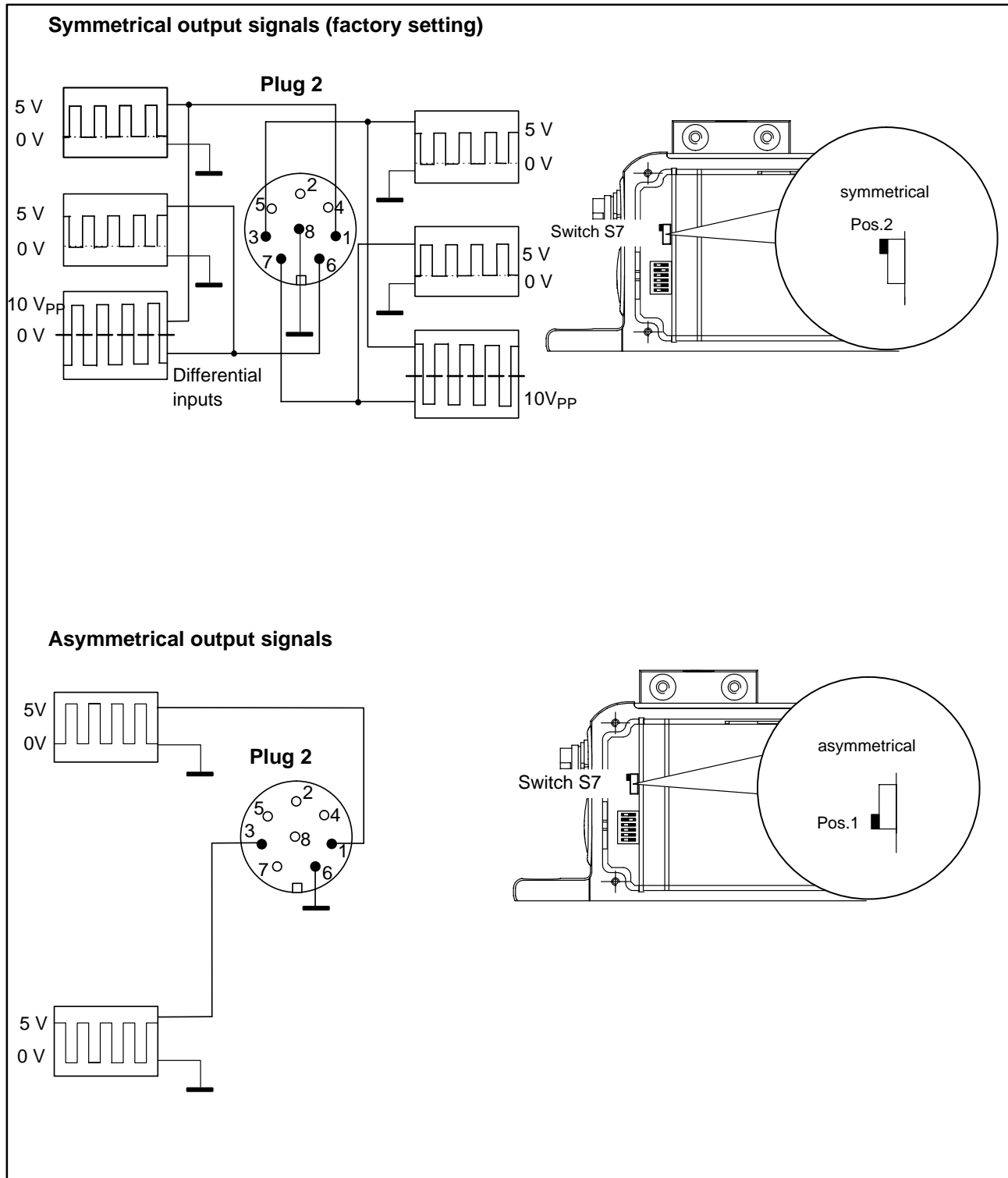

15.2 Circular run-out values

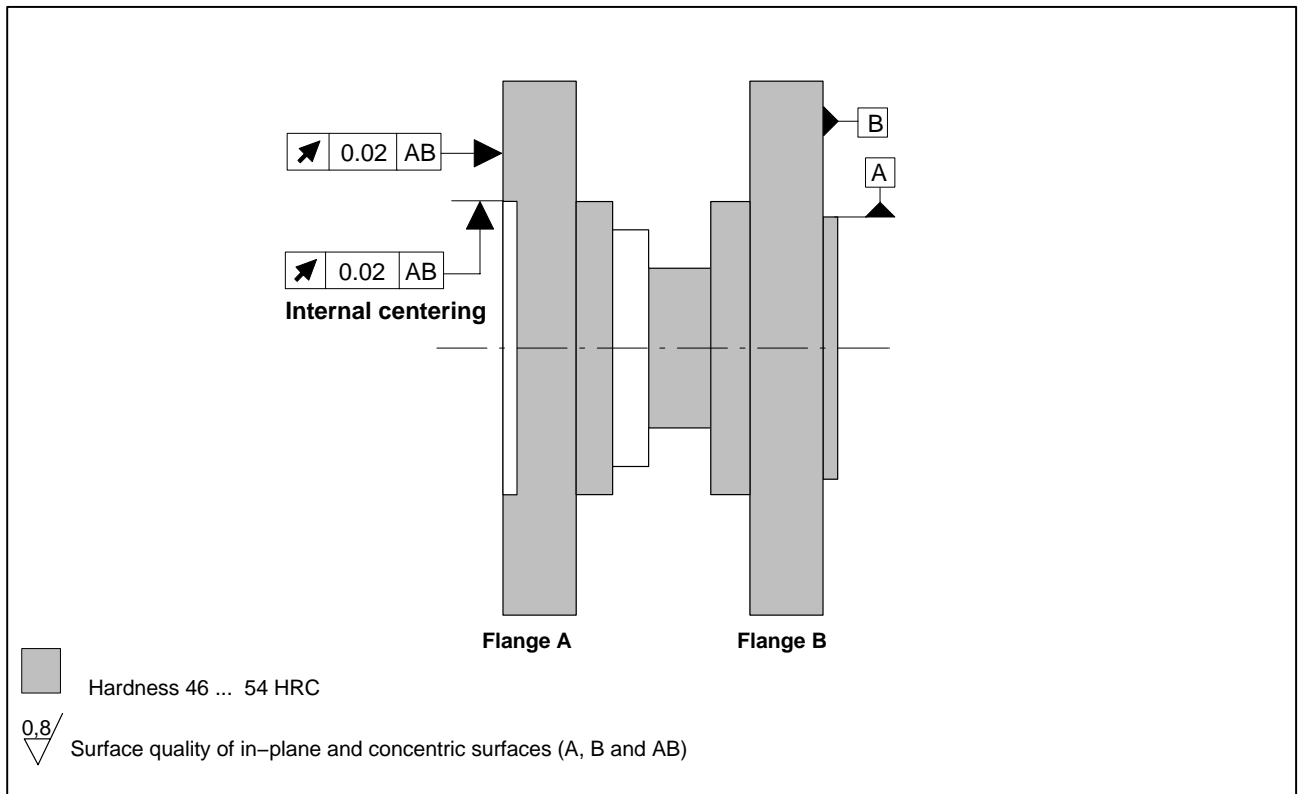

16 Order number

Code	Option 1: Measuring range up to
100R	100 kN·m
130R	130 kN·m
150R	150 kN·m
200R	200 kN·m
250R	250 kN·m
300R	300 kN·m

Code	Option 2: Nominal speed
N	Non-rotating
L	Nominal speed depending on meas. range 2000 rpm to 3000 rpm

Code	Option 3: Electrical configuration
PNJ	Output signal mV/V, depending on meas. range; Nominal (rated) sensitivity 1.1 ... 1.9 mV/V
SU2	Output signal 10 kHz \pm 5 kHz and \pm 10 V; Supply voltage 18 ... 30 V DC

Code	Option 4: Accuracy
S	Linearity deviation incl. hysteresis < 0.1; Standard sensitivity tolerance ^{*)}
K	DKD calibration certificate per DIN 51309 or EA-10/14: class 0.5, clockwise- and counterclockwise torque; sensitivity tolerance 0.1 %
W	DKD calibration certificate per DIN 51309 or EA-10/14: class 0.5, alternating torque; sensitivity tolerance 0.1 %

Code	Option 5: Rot. speed measuring system
0	Without rot. speed measuring system
1	With rot. speed measuring system; 180 pulses/revolution

Code	Option 6: Customized modification
S	No Customized modification

Order no.:

K-T10FH - - - - - - -

Ordering example:

K-T10FH - - - - - - -

^{*)} Option 1, Code 100R ... 150R: 0.25 %
Option 1, Code 200R ... 300R: 0.4 %

17 Accessories

Item	Order-No.
Ready made connecting cables	
Torque (rotating); option 2, code L	
Connecting cable torque, Binder 423 7-pole – D-Sub 15-pole, 6 m	1-KAB149-6
Connecting cable torque, Binder 423 – free ends, 6 m	1-KAB153-6
Torque (non-rotating); option 2, code N	
Connecting cable torque, Binder 423 – free ends, 6 m	1-KAB139A-6
Rotational speed	
Connecting cable rot. speed, Binder 423 8-pole – D-Sub 15-pole, 6 m	1-KAB150-6
Connecting cable rot. speed, Binder 423 8-pole – free ends, 6 m	1-KAB154-6
Male/female cable connectors	
Torque	
423G-7S cable socket, 7-pole, straight cable entry, for torque output	3-3101.0247
423W-7S cable socket, 7-pole, 90° cable entry, for torque output	3-3312.0281
Rotational speed	
423G-8S cable socket, 8-pole, straight cable entry, for speed output	3-3312.0120
423W-8S cable socket, 8-pole, 90° cable entry, for speed output	3-3312.0282
Connecting cable, by the meter	
Kab8/00-2/2/2	4-3301.0071

Modifications reserved.
All details describe our products in general form only. They are not to be understood as express warranty and do not constitute any liability whatsoever.

7-2002.2037

Hottinger Baldwin Messtechnik GmbH

Postfach 10 01 51, D-64201 Darmstadt

Im Tiefen See 45, D-64293 Darmstadt

Tel.: +49 6151 803-0 Fax: +49 6151 8039100

Email: support@hbm.com Internet: www.hbm.com



measurement with confidence

A2037-2.0 en