

Mounting instructions

Torque Flange

T10FS



Contents	Page
Safety instructions	6
1 Torque flange versions	10
2 Application	11
3 Structure and mode of operation	12
4 Mechanical installation	13
4.1 Conditions on site	14
4.2 Mounting position	14
4.3 Installation possibilities	15
4.3.1 Installation without undoing the antenna ring (without speed measuring system)	15
4.3.2 Installation with subsequent stator mounting (without speed measuring system)	16
4.3.3 Installation example with couplings	17
4.3.4 Installation example with joint shaft	17
4.4 Mounting the rotor	18
4.5 Installing the stator	20
4.6 Mounting of the clamp fixture	21
4.7 Installing the slotted disc (speed measuring system)	23
4.8 Fitting the mounting elements (speed measuring system)	24
4.8.1 Fixing the mounting elements	25
4.8.2 Installing the torque flange with the speed measuring system	25
4.9 Aligning the stator (speed measuring system)	27
4.9.1 Magnetic speed measuring system	27
4.9.2 Optical speed measuring system	31

5	Electrical connection	33
5.1	General instructions	33
5.2	Shielding design	33
5.3	Option 2, code KF1	34
5.3.1	Adaptation to the cable length	34
5.4	Option 2, code SF1/SU2	36
5.5	Supply voltage	39
6	Calibration	40
6.1	Calibration Option 2, code KF1	40
6.2	Calibration Option 2, code SF1/SU2	41
7	Settings	42
7.1	Torque output signal, code KF1	43
7.2	Torque output signal, code SF1/SU2	43
7.3	Setting up the zero point	44
7.4	Functional testing	45
7.4.1	Power transmission	45
7.4.2	Testing the optical speed module	46
7.5	Setting the pulse count	47
7.5.1	Magnetic speed measuring system	47
7.5.2	Optical speed measuring system	50
7.6	Vibration suppression (hysteresis)	51
7.7	Form of the rotation speed output signal	52
7.8	Type of the rotation speed output signal	53
7.9	Optical speed measuring system with a reference pulse	53
8	Loading capacity	55
8.1	Measuring dynamic torque	55
9	Maintenance	57
9.1	Torque flange maintenance	57
9.2	Speed module maintenance	57
9.2.1	Magnetic speed measuring system	57
9.2.2	Optical speed measuring system	57

10	Dimensions	58
10.1	Rotor dimensions	58
10.2	Rotor dimensions with the magnetic speed system	59
10.3	Stator dimensions	60
10.4	Stator dimensions with the magnetic speed system	61
10.5	Mounting dimensions	62
11	Order numbers, accessories	63
12	Specifications	64
13	Supplementary technical information	71
13.1	Output signals	71
13.1.1	Output MD torque (plug 1)	71
13.1.2	Output N: Speed and speed with a reference pulse (plug 2)	72
13.1.3	Plug 2, double frequency, stat. direction of rotation signal	73
13.2	Circular run-out values	74

Safety instructions

Use in accordance with the regulations

T10FS torque flanges are used exclusively for torque and rotation speed measurement tasks and control and adjustment tasks directly connected thereto. Use for any additional purpose shall be deemed to be **not** in accordance with the regulations.

In the interests of safety, the transducers should only be operated as described in the Operating Manual. It is also essential to observe the appropriate legal and safety regulations for the application concerned during use. The same applies to the use of accessories.

The transducers are not a safety element within the meaning of its use as intended. Proper and safe operation of these transducers require proper transportation, correct storage, assembly and mounting and careful operation.

General dangers of failing to follow the safety instructions

The transducers correspond to the state of the art and is fail-safe. The transducers can give rise to remaining dangers if it is inappropriately installed and operated by untrained personnel.

Everyone involved with the installation, commissioning, maintenance or repair of the transducers must have read and understood the Operating Manual and in particular the technical safety instructions.

Remaining dangers

The scope of supply and performance of the transducers covers only a small area of torque measurement technology. In addition, equipment planners, installers and operators should plan, implement and respond to the safety engineering considerations of torque measurement technology in such a way as to minimize remaining dangers. Prevailing regulations must be complied with at all times. Reference must be made to remaining dangers connected with torque measurement technology.

In this Operating Manual remaining dangers are pointed out using the following symbols:



Symbol: **DANGER**

Meaning: **Maximum danger level**

Warns of an **imminently** dangerous situation in which failure to comply with safety requirements **will** result in death or serious physical injury.



Symbol: **WARNING**

Meaning: **Potentially dangerous situation**

Warns of a **potentially** dangerous situation in which failure to comply with safety requirements **can** result in death or serious physical injury.



Symbol: **CAUTION**

Meaning: **Dangerous situation**

Warns of a potentially dangerous situation in which failure to comply with safety requirements **could** result in damage to property or some form of physical injury.

Symbols pointing out notes on use and waste disposal as well as useful information:



Symbol: **NOTE**

Means that important information about the product or its handling is being given.



Symbol: **CE mark**

The CE mark enables the manufacturer to guarantee that the product complies with the requirements of the relevant EC directives (the declaration of conformity is available at <http://www.hbm.com/HBMdoc>).

**Symbol:****Meaning: Statutory marking requirements for waste disposal**

National and local regulations regarding the protection of the environment and recycling of raw materials require old equipment to be separated from regular domestic waste for disposal.

For more detailed information on disposal, please contact the local authorities or the dealer from whom you purchased the product.

Conversions and modifications

The transducers must not be modified from the design or safety engineering point of view except with our express agreement. Any modification shall exclude all liability on our part for any damage resulting therefrom.

Qualified personnel

The transducers must only be installed and used by qualified personnel, strictly in accordance with the specifications and with safety requirements and regulations. It is also essential to observe the appropriate legal and safety regulations for the application concerned during use. The same applies to the use of accessories.

Qualified personnel means persons entrusted with the installation, fitting, commissioning and operation of the product who possess the appropriate qualifications for their function.

Prevention of accidents

According to the prevailing accident prevention regulations, once the T10F torque transducers have been mounted, a cover or casing has to be fitted as follows:

- The cover or casing must not be free to rotate.
- The cover or casing should avoid squeezing or shearing and provide protection against parts that might come loose.
- Covers and casing must be positioned at a suitable distance or so arranged that there is no access to any moving parts within.
- Covers and casing must also be attached if the moving parts of the torque flange are installed outside peoples' movement and operating range.

The only permitted exceptions to the above requirements are if the various parts and assemblies of the machine are already fully protected by the design of the machine or by existing safety precautions.

Warranty

In the case of complaints, a warranty can only be given if the torque flange is returned in the original packaging.

1 Torque flange versions

In the case of option 2 "electrical configuration", the T10FS torque flange exists in versions KF1, SF1 and SU2. The difference between these versions lies in the electrical inputs and outputs on the stator, the rotors are the same for all the versions of a measuring range. Alternatively, versions SF1 and SU2 can be equipped with a magnetic or optical speed measuring system (in the case of the optical system, with or without a reference pulse).

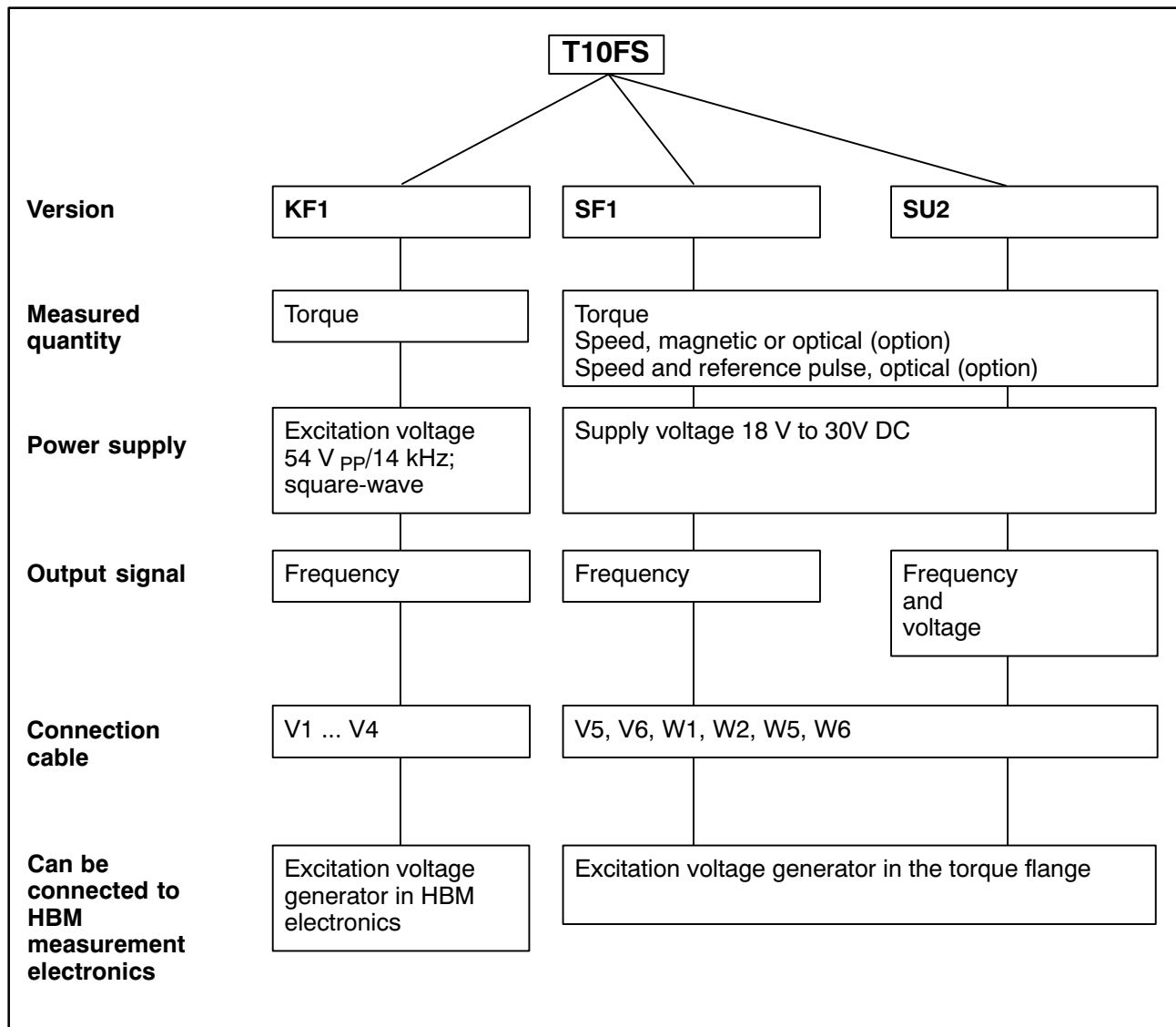

Fig.1.1: T10FS versions

You can find out which version you have from the stator identification plate. The version is specified in the "T10FS-..." number there.
Example: T10FS-001R-**SU2**-S-0-V1-Y (see also Page 63).

2 Application

T10FS torque flanges record static and dynamic torque on fixed or rotating shafts and also return RS-422 signals with direction of rotation information to determine the speed. With an optical measuring system, a reference pulse can also be output with the speed pulses. Test beds can be extremely compact because of the short construction of the measurement flanges. They offer a very wide range of applications.

In addition to conventional test-bench applications (motor, roller and gear test benches) new solutions are possible for torque measurements partly integrated into the machines. Here, you benefit from the T10FS torque flanges' special characteristics:

- low rotor weights
- low mass moments of inertia
- small outside diameters
- no bearings, no slip rings

Thanks to the bearing-free design and the contactless transmission of excitation voltage and measured values, there are no friction or bearing heating effects.

Torque flanges are supplied for nominal (rated) torques from 100 N·m to 10 kN·m. Depending on the nominal (rated) torque, maximum speeds of up to 24 000 min⁻¹ are permissible.

T10FS torque flanges are reliably protected against electromagnetic interference. They have been tested with regard to EMC according to the relevant European standards, and carry the CE mark.

3 Structure and mode of operation

Torque flanges consist of two separate parts: the rotor and the stator. The rotor comprises the measuring body and the signal transmission elements.

Strain gages (S.G.) are mounted on the measuring body. The rotor electronics for transmitting the bridge excitation voltage and the measurement signal are located centrally in the flange. The transmitter coils for the non-contact transmission of excitation voltage and measurement signal are located on the measuring body's outer circumference. The signals are sent and received by a separable antenna ring. The antenna ring is mounted on a housing that includes the electronic system for voltage adaptation and signal conditioning. The connector for the torque signal, the voltage supply and the speed signal (option) are located on the stator. The antenna ring should be mounted more or less concentrically around the rotor (see chapter 4).

A magnetic or optical sensor performs the speed measurement. With a magnetic measuring system, a magnetized rotor is sampled by means of a magneto-resistive sensor (MR).

The optical sensor works on the infrared transmitted light barrier principle. The reference pulse is generated by a magnet in the slotted disc and a magneto-resistive sensor. In the case of option2 (speed measuring system), code L, the speed sensor is mounted on the stator, the customer attaches the associated slotted disc on the rotor. In the case of code H, the slotted disc is already mounted on the rotor.

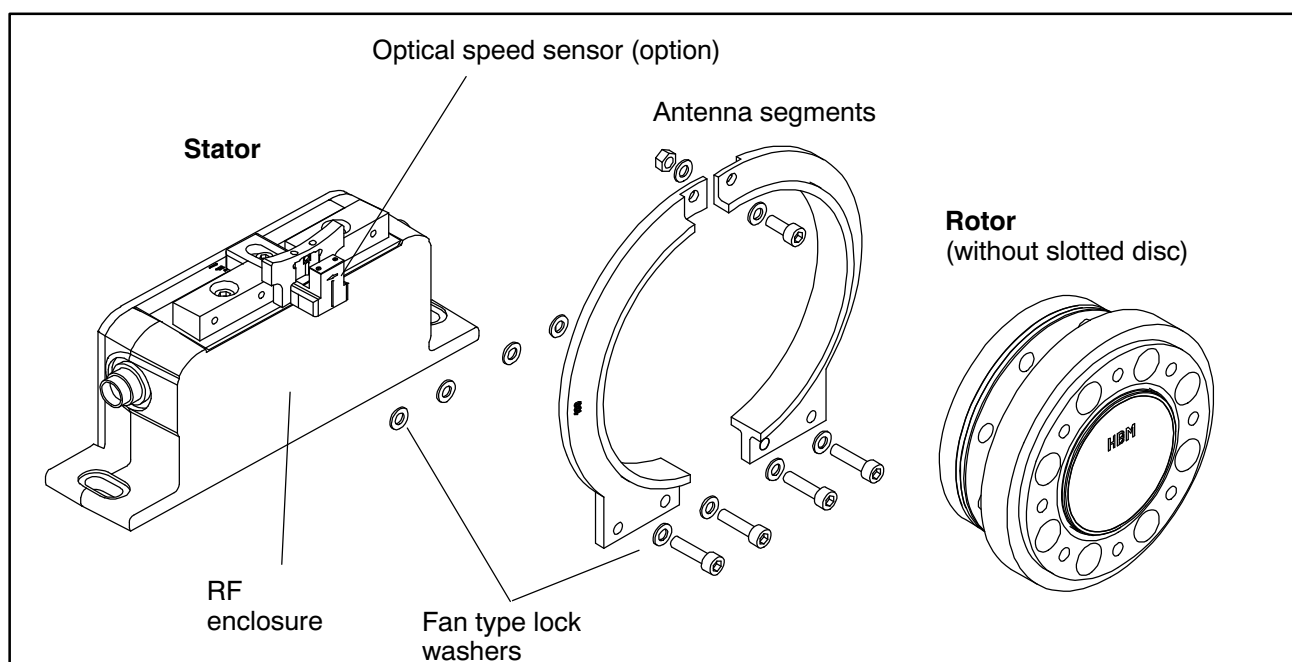

Fig.3.1: Mechanical structure, exploded view

4 Mechanical installation

Handle the torque flange carefully. The transducer might suffer permanent damage from mechanical shock (dropping), chemical effects (e.g. acids, solvents) or thermal effects (hot air, steam).

With alternating loads, you should glue the rotor connection-screws into the counter thread with a screw locking device (medium strength) to exclude prestressing loss due to screw slackening.

An appropriate shaft flange enables the T10FS torque flanges to be mounted directly. It is also possible to mount a joint shaft or relevant compensating element directly on the rotor (using an intermediate flange when required). Under no circumstances must the permissible limits specified for bending moments, transverse and longitudinal forces be exceeded. Due to the T10FS torque flanges' high torsional stiffness, dynamic changes on the shaft run are minimized.

Do in any case check the effect on critical speeds and natural torsional vibrations to avoid overloading the measurement flanges due to the resonance step-up.

Hinweis:

 **Even if the unit is installed correctly, the zero point adjustment made at the factory can shift by approx. ± 150 Hz. If this value is exceeded, we advise you to check the mounting conditions. If the residual zero offset when the unit is removed is greater than ± 50 Hz, please send the transducer back to the Darmstadt factory for testing.**

For correct operation, do in any case observe the mounting dimensions (see page 62).

4.1 Conditions on site

T10FS torque flanges are protected to IP54 according to EN 60529. They must be protected against coarse dirt particles, dust, oil, solvents and humidity. During operation, the prevailing safety regulations for the security of personnel must be observed (see "Safety instructions").

There is wide ranging compensation for the effects of temperature on the output and zero signals of the T10FS torque flange (see specifications on page 64). This compensation is carried out at static temperatures. This guarantees that the circumstances can be reproduced and the properties of the transducer can be reconstructed at any time.

If there are no static temperature ratios, for example, because of the temperature differences between the measuring body and the flange, the values given in the specifications can be exceeded. Then for accurate measurements, static temperature ratios must be obtained by cooling or heating depending on the application. As an alternative, check thermal decoupling, by means of heat radiating elements such as multiple disc couplings.

4.2 Mounting position

The measurement flange can be mounted in any position. With clockwise torque, the output frequency is 10 kHz to 15 kHz. With HBM amplifiers or with the "voltage output" option, a positive output signal (0 V to +10 V) is present.

In the case of the speed measuring system, an arrow is attached to the head of the sensor to clearly define the direction of rotation. If the measurement flange moves in the direction of the arrow, the connected HBM measuring amplifiers give off a positive output signal (0 V...+10 V).

4.3 Installation possibilities

In principle, there are two possibilities for torque flange mounting: with the antenna ring complete or dismantled. We recommend proceeding as described in subsection 4.3.1. If installation in accordance with 4.3.1 is not possible, (e.g. in the case of subsequent stator replacement or mounting with a speed measuring system), you will have to dismantle the antenna ring. It is essential in this case to comply with the notes on assembling the antenna segments (see "Installing the stator" and "Installing the slotted disc").

4.3.1 Installation without undoing the antenna ring (without speed measuring system)

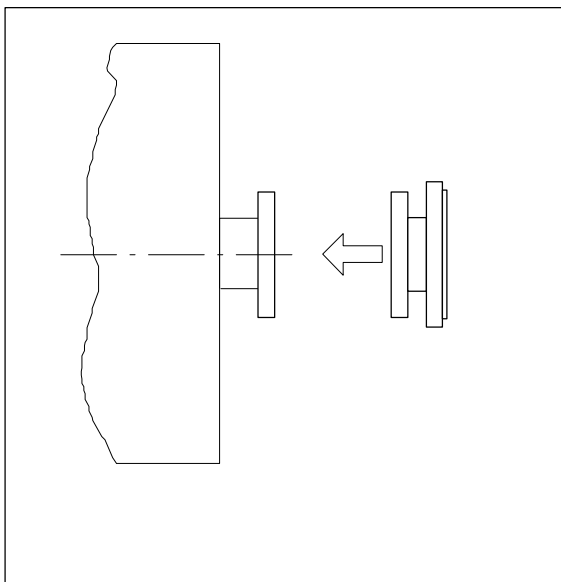

1. Install rotor

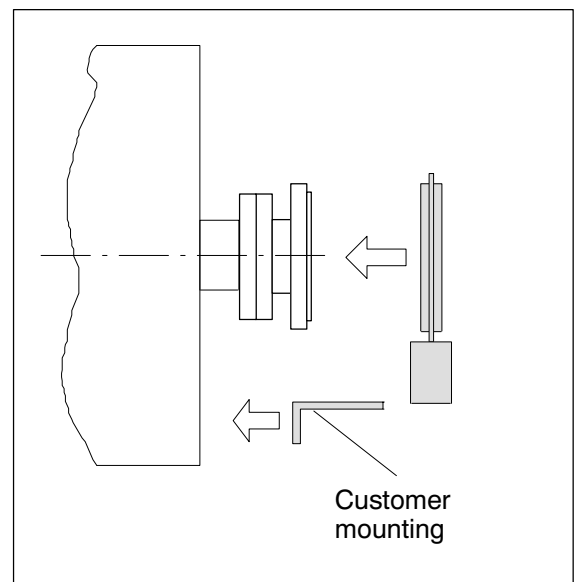

2. Install stator

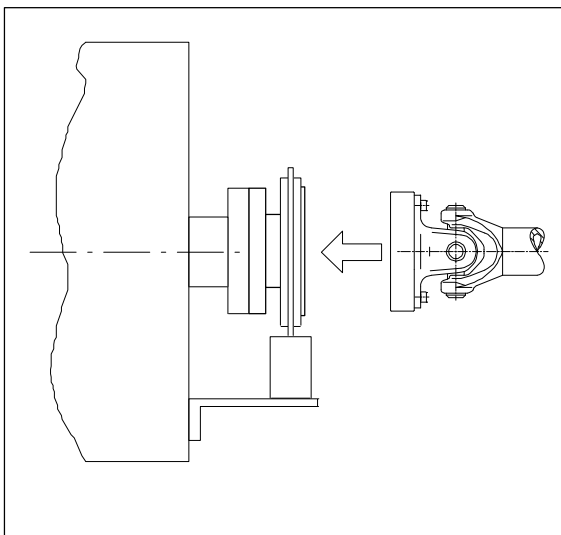

3. Finish installation of shaft run

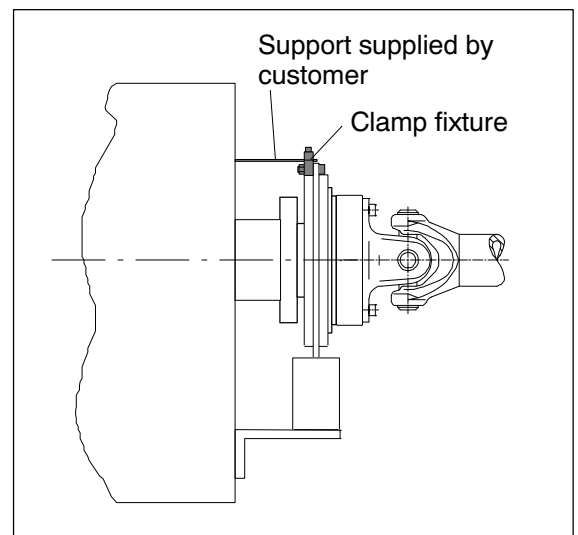

4. Mount clamp fixture where required.

4.3.2 Installation with subsequent stator mounting (without speed measuring system)

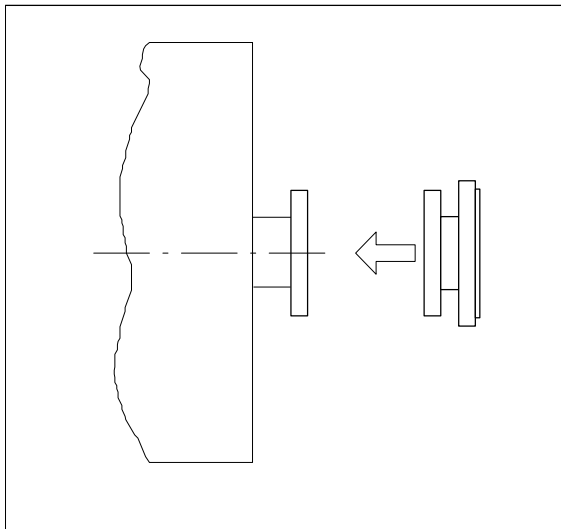

1. Install rotor

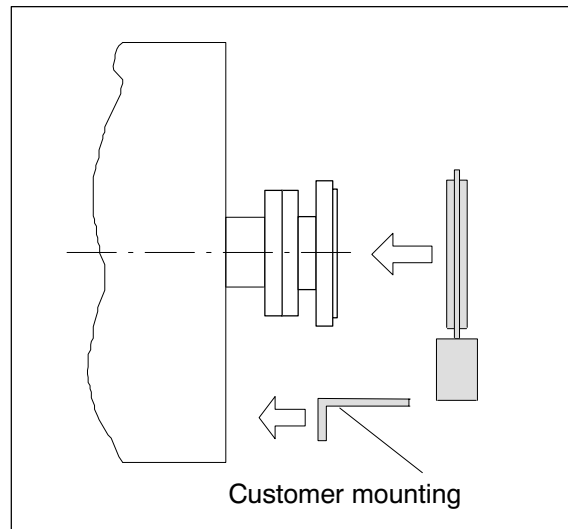

2. Install shaft run

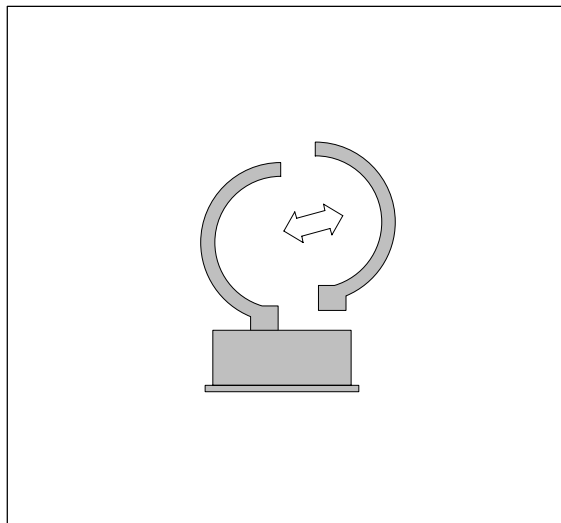

3. Remove one antenna segment

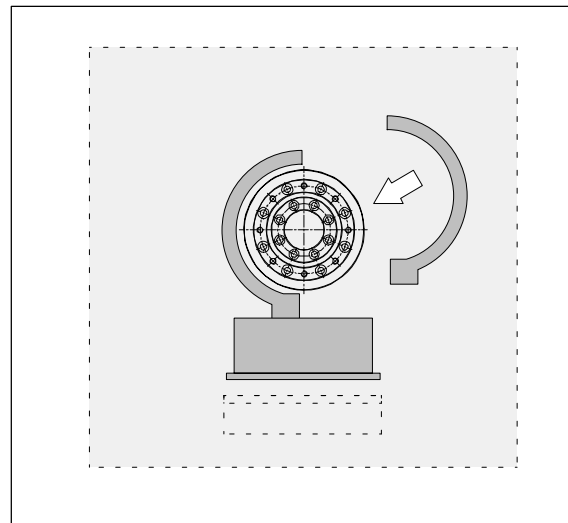

4. Install antenna segment around shaft run

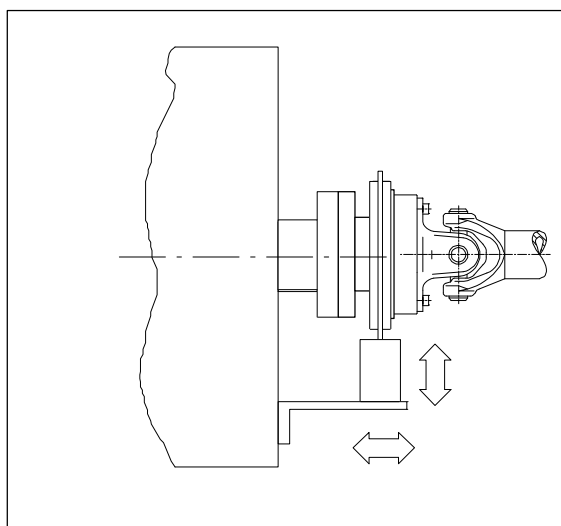

5. Align stator and finish installation

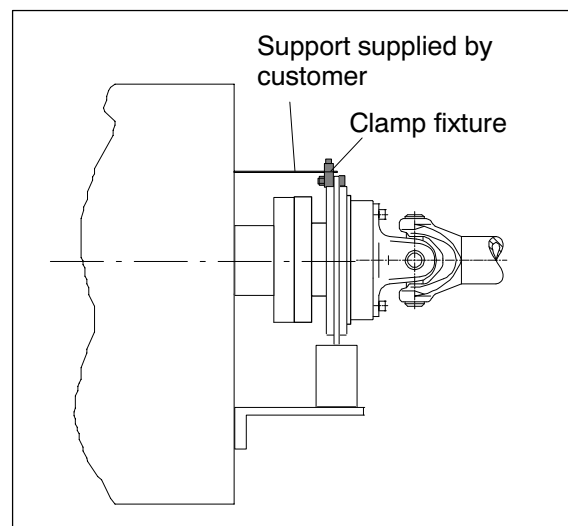

6. Mount clamp fixture where required

4.3.3 Installation example with couplings

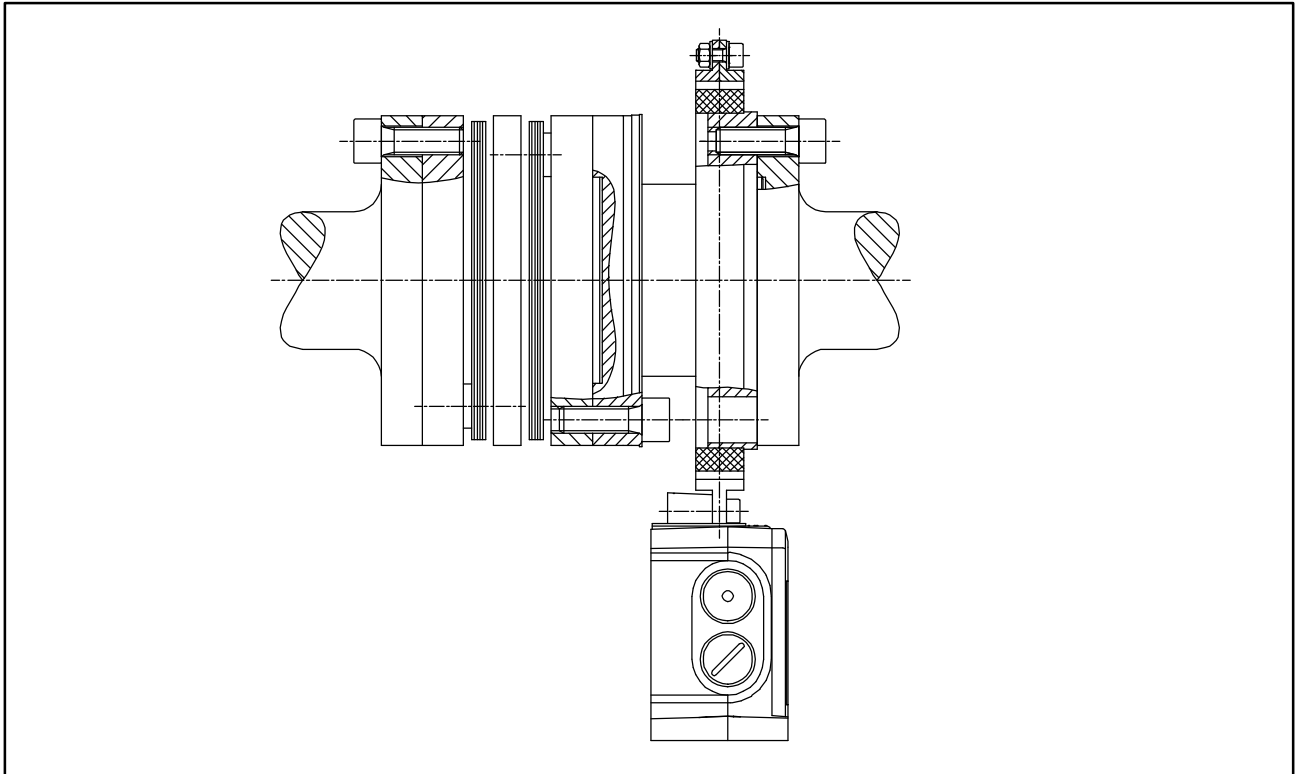

Fig. 4.1: Installation example with coupling

4.3.4 Installation example with joint shaft

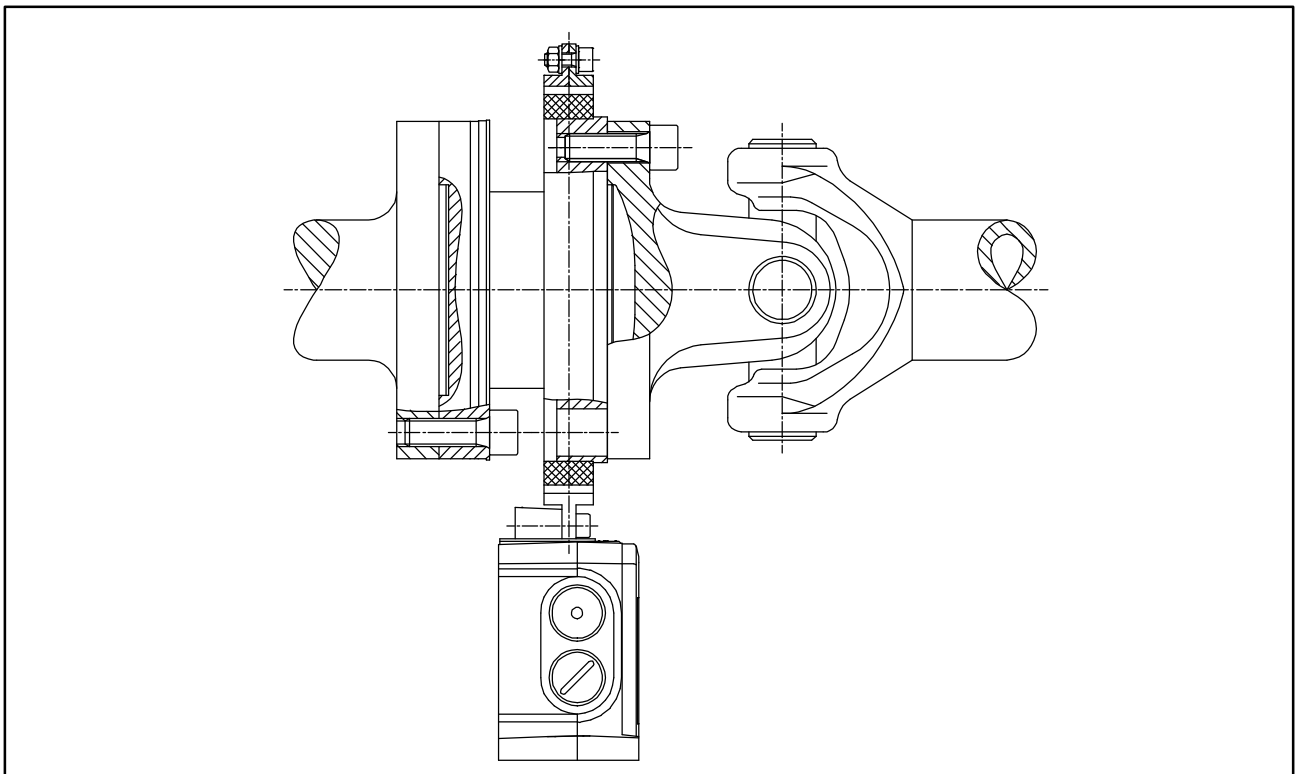

Fig. 4.2: Installation example with joint shaft

4.4 Mounting the rotor

Additional installation notes for the speed measuring system can be found in Section 4.7, Page 23.

Hinweis:

In general, the rotor identification plate is no longer visible after mounting. This is why we include with the rotor additional stickers with the important ratings, which you can attach to the stator or any other relevant test-bench components. You can then refer to them whenever there is anything you wish to know, such as the calibration signal. To explicitly assign the data, the identification number and the measuring range are engraved on the rotor where they can be seen from outside (see Fig. 4.3).

1. Prior to installation, clean the measurement flange's and counter flanges' plane surfaces. For safe torque transfer, the surfaces must be clean and free from grease. Use a piece of cloth or paper soaked in solvent. When cleaning, make sure that you do not damage the transmitter coils.

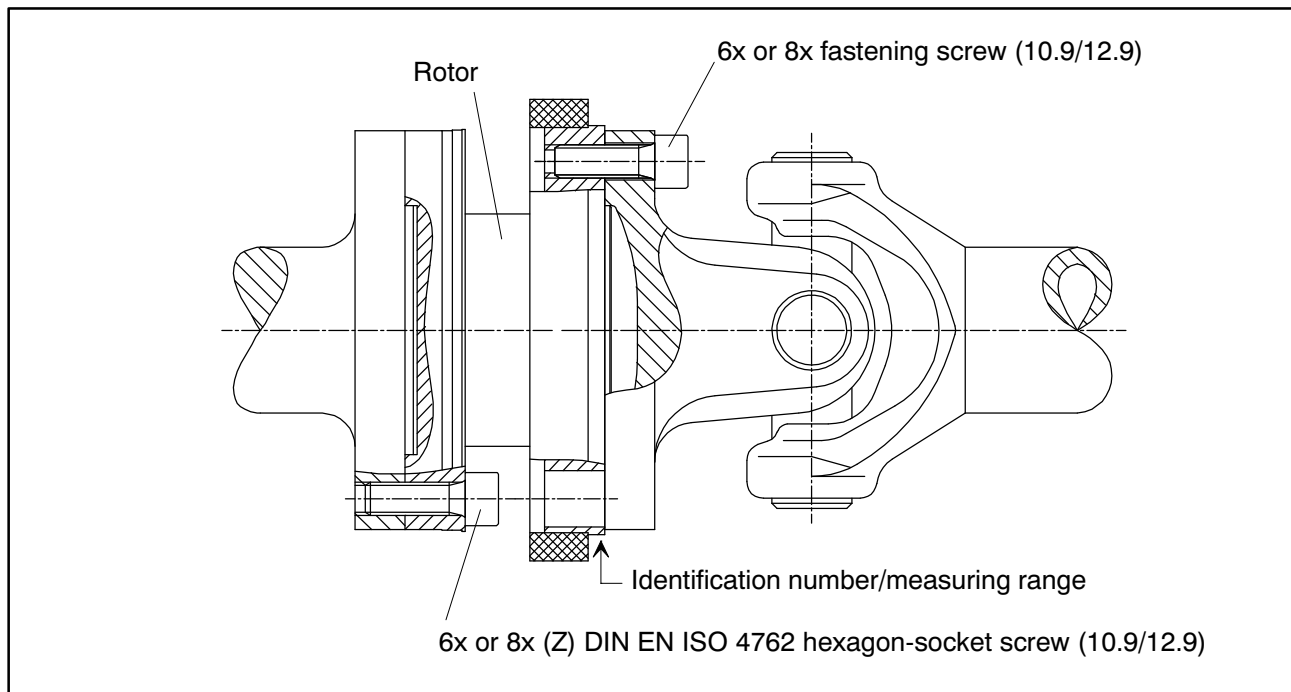

Fig. 4.3: Screwed joint of the rotor

- Use eight **DIN EN ISO 4762 hexagon-socket screws of property class 10.9 (measuring range $\geq 3 \text{ kN}\cdot\text{m}$: 12.9)**, of the appropriate length (depending on the connection geometry) to screw-fasten the rotor.

We recommend fillister-head screws DIN EN ISO 4762 or similar, blackened, smooth-headed, permitted size and shape variance in accordance with DIN ISO 4759, Part 1, product class A.

With alternating load: Use a screw locking device (e.g. LOCTITE no. 242) to glue the screws into the counter thread to exclude prestressing loss due to screw slackening.

- Fasten all screws with the specified tightening torque (Table 4.1).
- For further mounting of the shaft run, there are eight tapped holes on the rotor. Also use screws of property class 10.9 (or 12.9) and fasten with the tightening torque specified in Table 4.1.



CAUTION

With alternating loads, use a screw locking device to glue the connecting screws into place. Guard against contamination from varnish fragments.

Nominal (rated) torque (N·m)	Fastening screws (Z) ¹⁾	Fastening screws Property class	Specified tightening torque (N·m)
100	M8	10.9	34
200			
500	M10	10.9	67
1k	M10		67
2k	M12		115
3k	M12	12.9	135
5k	M14		220
10k	M16		340

Table 4.1: Fastening screws

¹⁾ DIN EN ISO 4762; black/oiled/ $\mu_{\text{tot}}=0.125$

4.5 Installing the stator

On delivery, the stator has already been installed and is ready for operation. The antenna segments can be separated from the stator, for example, for maintenance or to facilitate stator mounting. To stop you modifying the center alignment of the segment rings opposite the base of the stator, we recommend that you separate only one antenna segment from the stator.

If your application does not require the stator to be dismantled, proceed as described in points 2., 6., 7. and 8.

Version with speed measuring system

As the optical speed sensor includes the slotted disc, it is not possible to move the stator axially over the pre-assembled rotor. In this case, you should also comply with Section 4.7.

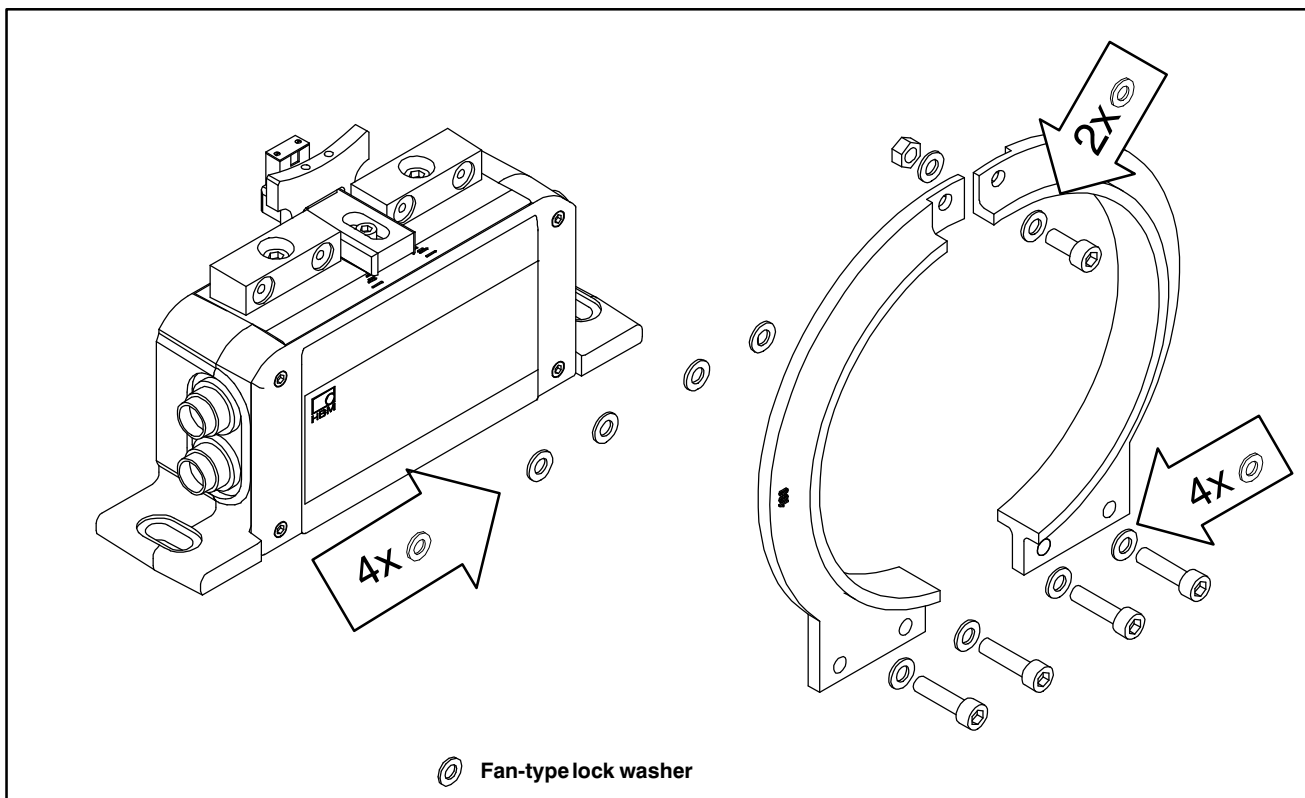
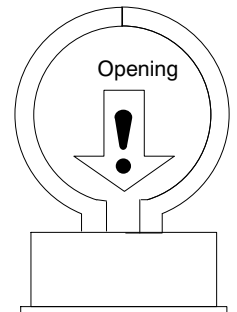

Fig. 4.4: Screw fittings of the antenna segments

1. Slacken and remove the screw fittings (M5) on one antenna segment. Make sure that the fan-type lock washers are not lost.
2. Use an appropriate base plate to install the stator housing in the shaft run so that there is sufficient possibility for horizontal and vertical adjustments. Do not yet fasten the screws.
3. Now reinstall the antenna segment removed under point 1. on the stator with two hexagon-socket screws and the fan-type lock washers. Make sure that none of the fan-type lock washers necessary for a defined contact resistance are missing (see Fig. 4.4). Do not yet fasten the screws.

4. Install the two antenna segments' upper connecting screw so that the antenna ring is closed. Also pay attention to the fan-type lock washers.
5. Now fasten all antenna-segment screw fastenings with a tightening torque of 5 N·m.
6. Align antenna and rotor so that the antenna encloses the rotor coaxially. Please observe the permissible alignment tolerances stated in the specifications.
7. Now fasten the screw fitting of the stator housing.
8. Make sure that the opening in the lower part of the antenna segments is clear of electrically conductive foreign bodies.



CAUTION

To make sure that they function perfectly, the fan-type lock washers (A5.3-FST DIN 6798 ZN/galvanized) must be replaced after the antenna screw fastening has been loosened three times.

4.6 Mounting of the clamp fixture

Depending on the operating conditions, the antenna ring may be excited to vibrate. This effect is dependent on

- the speed
- the antenna diameter (depends in turn on the measuring range)
- the design of the machine base

To avoid vibrations, a clamp fixture is enclosed with the torque flange enabling the antenna ring to be supported.

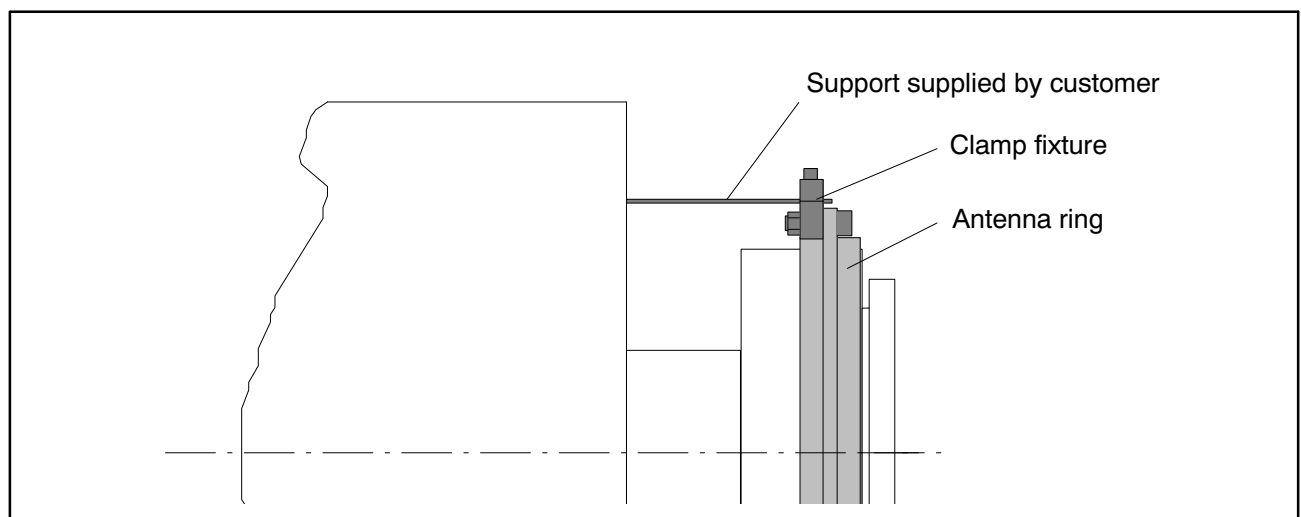

Fig. 4.5: Supporting the antenna ring

Assembly sequence

1. Loosen and remove the upper antenna segment screw fitting.
2. Fasten the clamp fixture with the enclosed screw fitting as shown in Fig. 4.6. It is essential to use the new fan-type locking washers.
3. Clamp a suitable support element (we recommend a threaded rod $\varnothing 3 \text{ mm} \dots 6 \text{ mm}$) between the upper and lower parts of the clamp fixture and tighten the clamping screws.

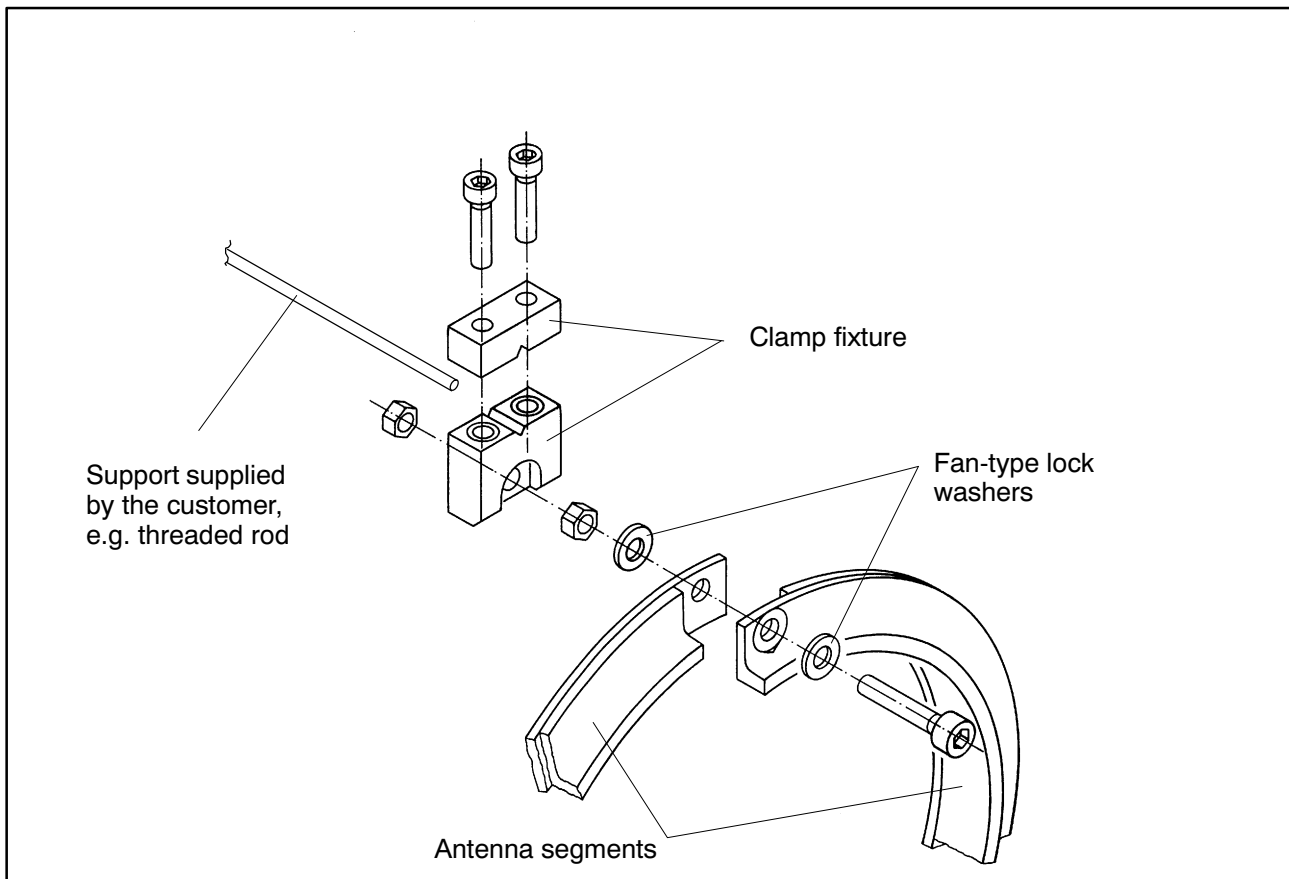

Fig. 4.6: Mounting of the clamp fixture

4.7 Installing the slotted disc (speed measuring system)

To prevent the slotted disc of the optical speed measuring system being damaged in transit, it is not mounted on the rotor in the case of measurement flanges with option 2, code L (nominal (rated) speed 8000 min^{-1} to 15000 min^{-1}). Before installing the rotor, it must be attached in the shaft run.

The associated speed sensor is already mounted on the stator.

The requisite screws, a suitable screwdriver and the screw locking device are included in the list of components supplied.

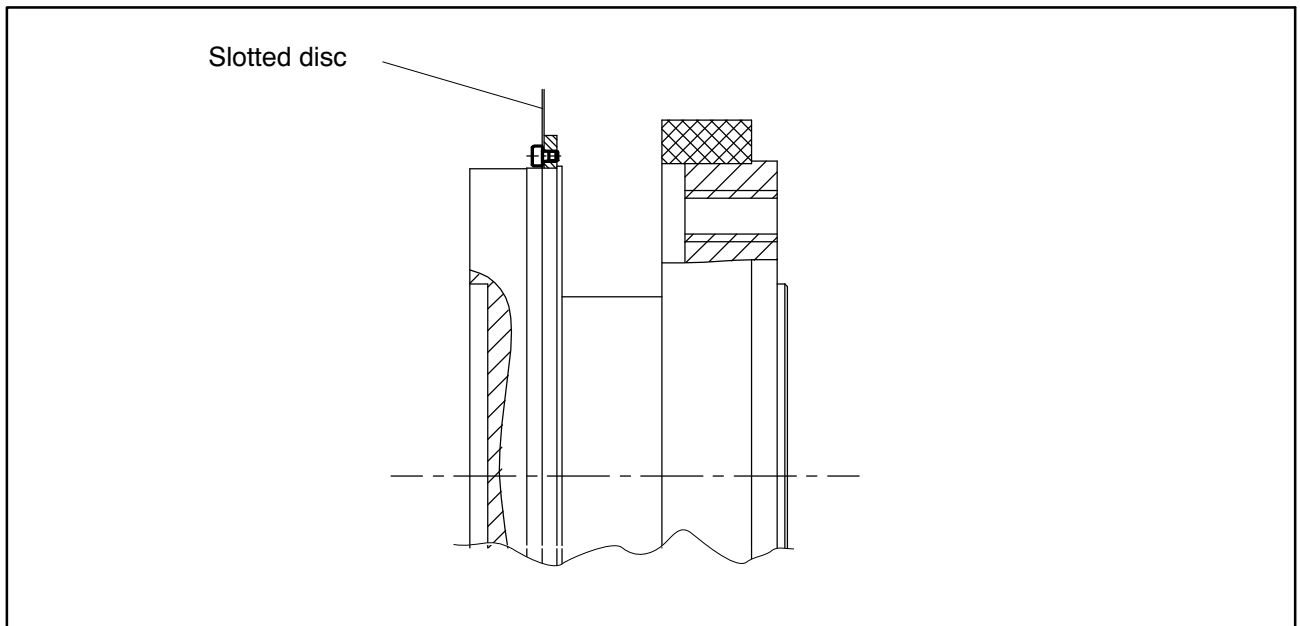

Fig. 4.7: Mounting the slotted disc on the rotor



CAUTION

When carrying out installation work, be careful not to damage the slotted disc!

Assembly sequence

1. Push the slotted disc onto the rotor and align the screw holes.
2. Apply some of the screw locking device to the screw thread and tighten the screws (tightening torque $< 15 \text{ N}\cdot\text{cm}$).

4.8 Fitting the mounting elements (speed measuring system)

Three mounting elements with screws are included with the torque flange to prevent the speed sensor being damaged during installation. The mounting elements hold the rotor centrally in the antenna ring, making installation easier and safer.



CAUTION

The mounting elements are only an aid to installation and must be removed before the initial operation of the torque flange!

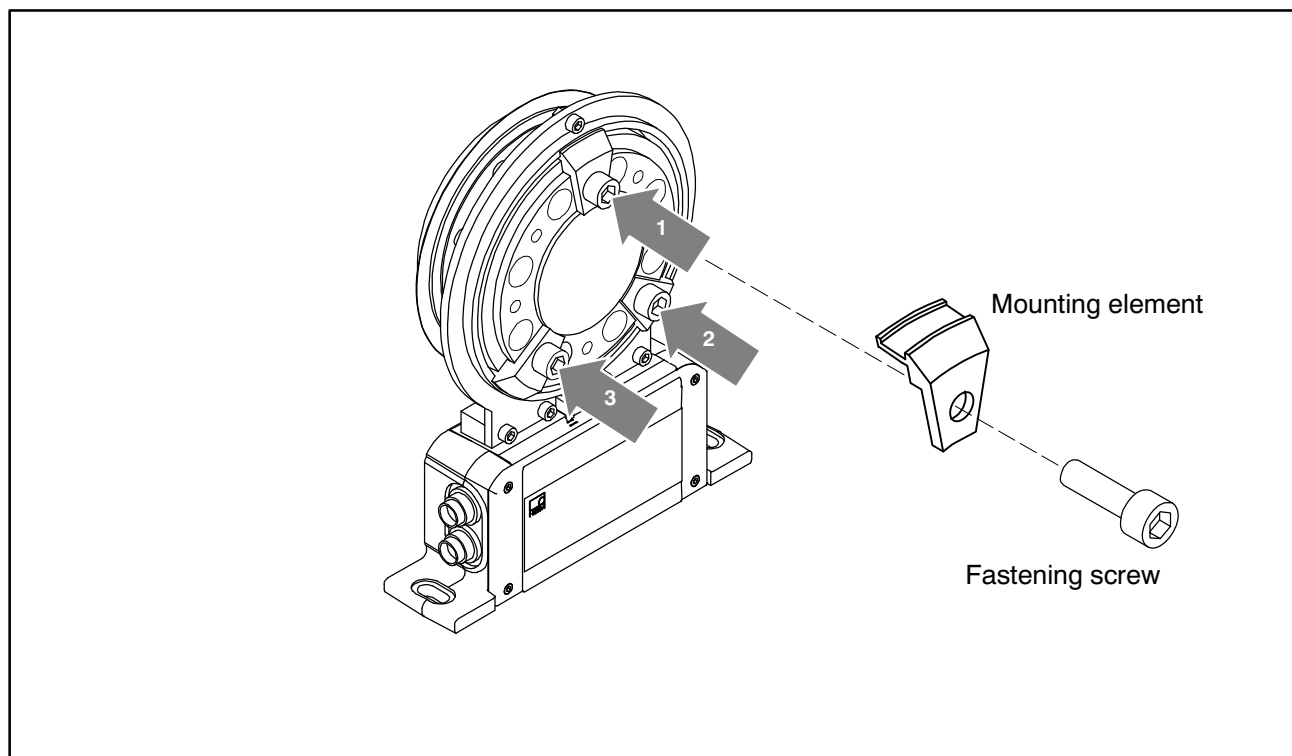

Fig. 4.8: Inserting the mounting elements

4.8.1 Fixing the mounting elements

1. Place the rotor with the identification plate upward on a flat base.
For the optical speed measuring system only:
Hold the stator at a slight slant and push it over the rotor until the slotted disc is located in the optical sensor (Step A, Fig. 4.9). Tilt the stator over the rotor until the antenna ring completely covers the transformer (Step B, Fig. 4.9).

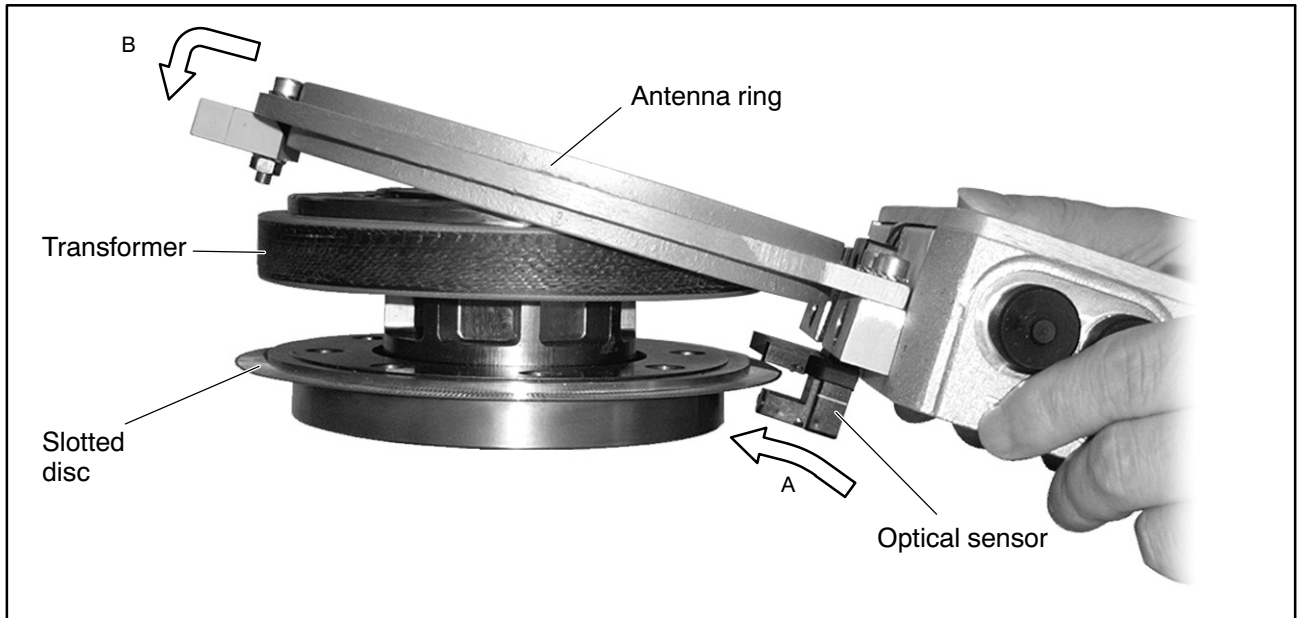

Fig. 4.9: Installing the mounting elements

2. Hold the stator centrally over the rotor and one after the other, push the three mounting elements between the transformer and the antenna ring. The mounting elements should be evenly distributed around the circumference (approx. every 120°).
3. Screw the fastening screws of the mounting elements into the tapped holes of the flange and gently tighten them by hand.

4.8.2 Installing the torque flange with the speed measuring system

1. Mount the torque flange in the shaft run so that the bearing surface of the stator base lies on the prepared mounting surface free from play and stress.
2. Fasten the rotor with 8 screws in the shaft run (for the property class, see Table 4.1, Page 19). Initially, the screws should only be hand-tight.
3. Compensate for any possible misalignment of the stator by putting adjusting washers underneath or by adjusting the base.
4. Fasten the base retaining screws; only tighten them gently at first, so that the mounting elements do not get jammed.
5. Remove the mounting elements (if a mounting element should get jammed, try to move it to the left or right).

Hinweis:

 **It is essential to keep the mounting elements and fastening screws in case any modifications are needed!**

6. Tighten the stator retaining screws. The stator must rest at the markers or stops. The rotor must turn freely.
7. Check whether the axial and radial tolerances have been maintained.
8. With a torque wrench, definitively tighten the fastening screws of the rotor in a diagonally opposite sequence (for tightening torques, see Table 4.1, Page 19).
9. Use a test run (starting at low rotation speeds) to check the correct concentricity of the rotor.

When machines are flexibly suspended, fairly large radial and longitudinal movements may occur. If the movements exceed the permissible limits (see Specifications, Page 64ff) you must make sure that the stator follows the rotor's sequence of motions.

When couplings are inserted, possible longitudinal and radial play must also be taken into account.

4.9 Aligning the stator (speed measuring system)

The stator can be mounted in any position (for example, "upside down" installation is possible).

For measuring mode to operate perfectly, the speed sensor (pole ring/slotted disc) of the speed measuring system must be positioned at a defined point on the sensor.

Hinweis:

 To attach the stator, we recommend the use of M6 screws with plain washers (width of oblong hole, 9 mm). This size of screw guarantees the necessary travel for alignment.

4.9.1 Magnetic speed measuring system

Hinweis:

 In the magnetic speed measuring system, the pole ring of the rotor and the sensor head of the stator are matched to each other. To enable the specified pulse quality to be maintained, torque transducer components from different consignments must not be interchanged. Therefore, compare the identification numbers of rotor and stator before installation!

Axial alignment

There are markers on the sensor head for axial alignment (orientation lines). When installed, the axial inner surface of the pole ring should be exactly over the axial orientation line. Divergence of up to ± 1.5 mm is permissible in measuring mode (total of static and dynamic shift), in this case however, the pulse tolerance will be greater.

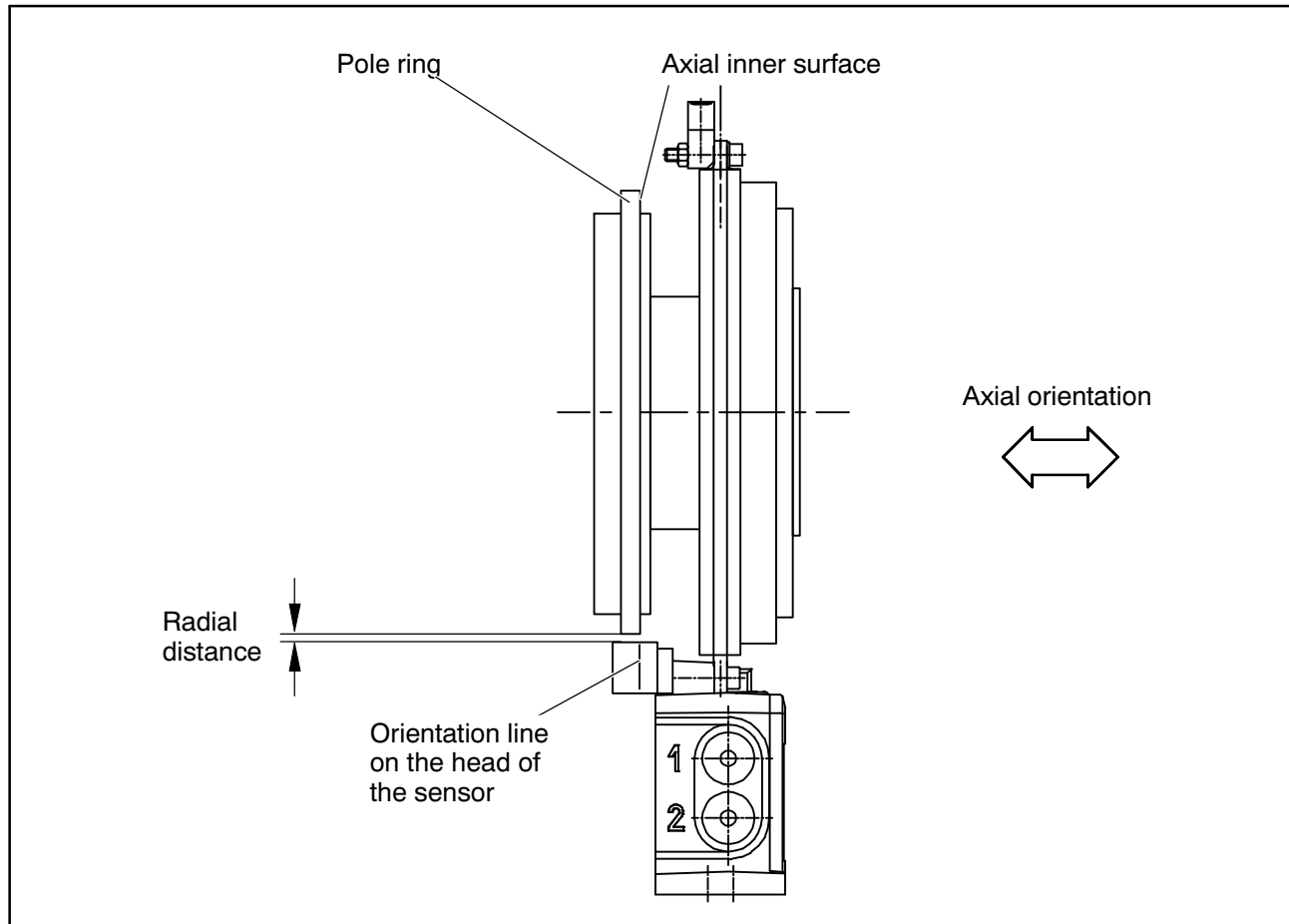



Fig. 4.10: Position of the pole ring to the sensor head

Radial alignment

The rotor axis and the optical axis of the speed sensor must be along a line at right angles to the stator platform. For radial alignment, the radial distance has to be maintained (see Fig. 4.10). A vertical orientation line on the sensor head facilitates tangential alignment (see Fig. 4.11).

Hinweis:

 **The mounting conditions are decisive for the pulse tolerance. Make every effort to maintain or remain under the nominal (rated) distance specified in Table 4.2. If the nominal (rated) distance is exceeded or the rotor and the stator are not aligned optimally, the pulse tolerance will be greater. Pulse precision can be optimized by setting the minimum distance (0.3 mm).**

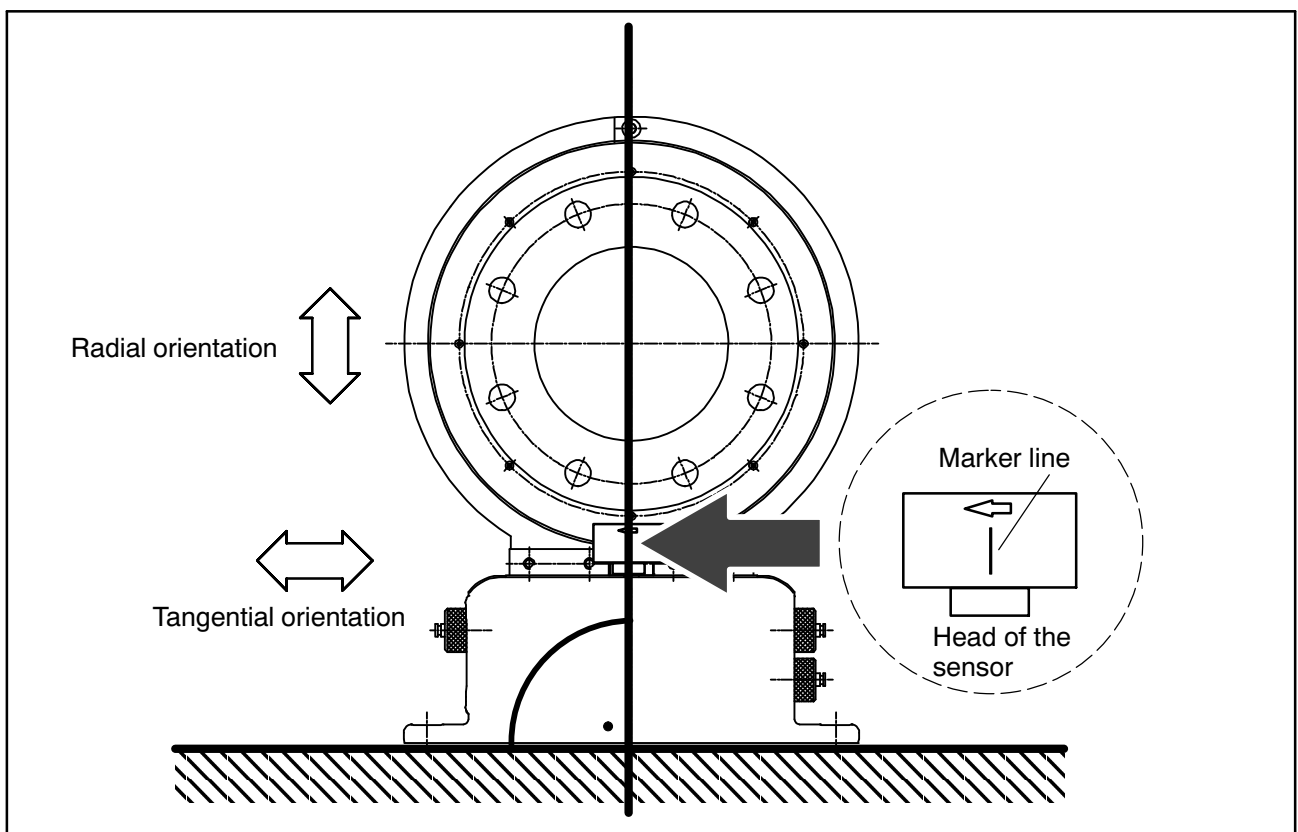

Fig. 4.11: Orientation markers on the sensor

Check radial nominal distance a with a distance gage and compensate for any possible misalignment of the stator by putting adjusting washers underneath or by adjusting the base of the stator. You can also use the central fastening screw on the sensor head for fine adjustments (setting range ± 1.5 mm).

Measuring range	100 N·m ... 3 kN·m	5 kN·m/10 kN·m
Radial nominal distance in mm	1.0	1.2
Actuation distance range in mm	0.3 ... 1.8	0.3 ... 2.2

Table 4.2: Radial nominal distance for the magnetic speed measuring system

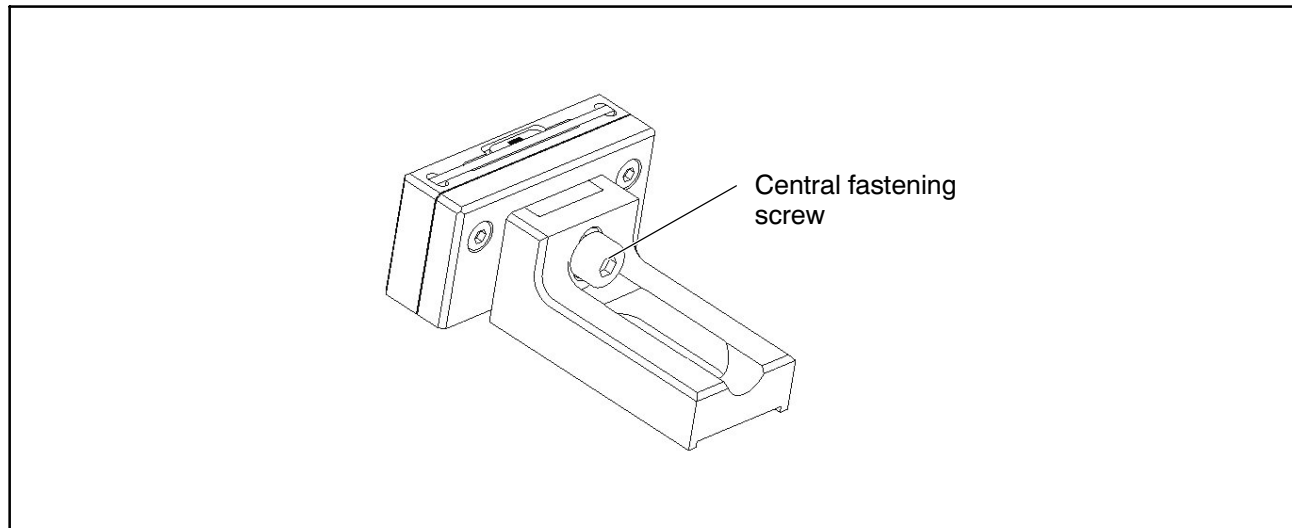

Fig. 4.12: Central fastening screw on the sensor head

1. Loosen the fastening screw (do not remove it!).
2. Set nominal distance a .
3. Tighten the screw at approx. 3 N·m.
4. Check the radial distance once again with a distance gage.

4.9.2 Optical speed measuring system

Axial alignment

There are markers in the optical sensor for axial alignment (orientation lines). When installed, the slotted disc should be exactly above these orientation lines. Divergence of up to ± 2 mm is permissible in measuring mode (total of static and dynamic shift).

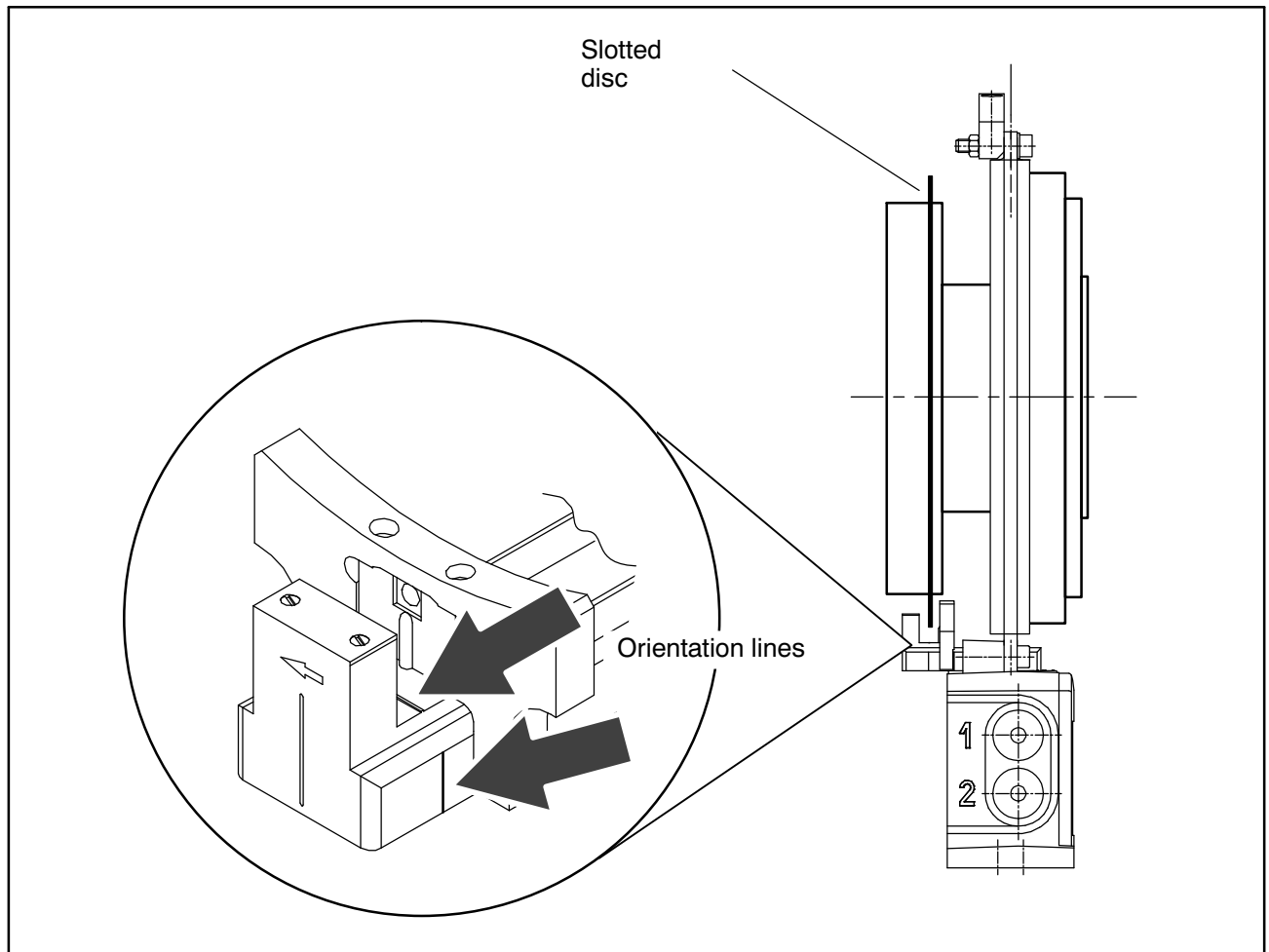

Fig. 4.13: Position of the slotted disc in the speed sensor

Radial alignment

The rotor axis and the optical axis of the speed sensor must be along a line at right angles to the stator platform. A vertical marker line on the head of the sensor serves as an orientation guide.

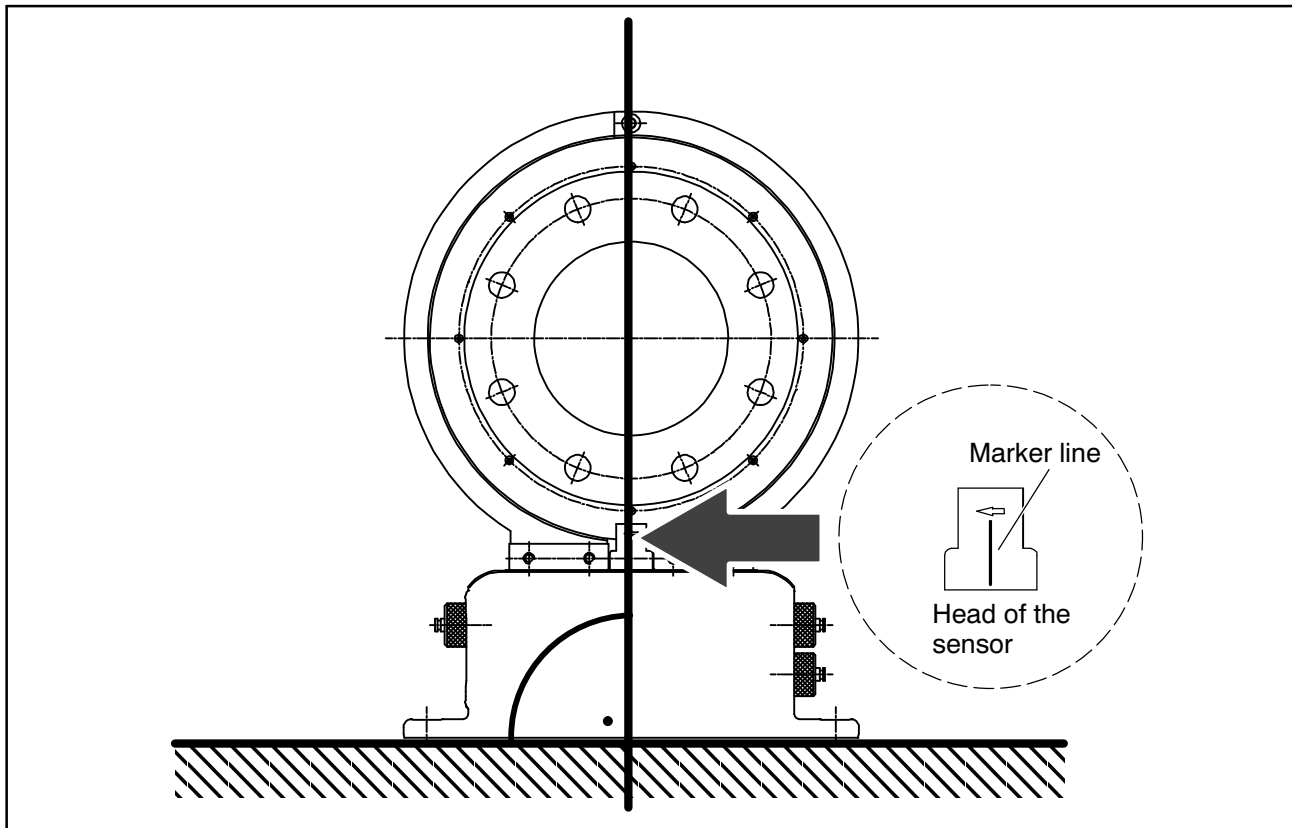

Fig. 4.14: Orientation markers on the stator

5 Electrical connection

5.1 General instructions

We recommend to use shielded, low-capacitance cable from HBM for the electrical connection between torque transducer and measuring amplifier.

With cable extensions it is important to ensure that a good connection is provided, with minimum contact resistance and good insulation. All plug connections or cap nuts have to be tightened firmly.

Do not route measurement cables in parallel to power lines and control circuits. If this is not possible (for example in cable ducts), maintain a minimum distance of 50 cm and protect the cable with a steel tube.

Avoid transformers, motors, contactors, thyristor controllers and similar sources of stray fields.



CAUTION

Transducer connection cables from HBM with attached connectors are identified in accordance with their intended purpose (Md or n). When cables are shortened, inserted into cable ducts or installed in control cabinets, this identification can get lost or become concealed. If this is the case, it is essential for the cables to be re-labeled!

5.2 Shielding design

The cable shielding is connected in accordance with the Greenline concept. This encloses the measuring system (without a rotor) in a Faraday cage. It is important that the shield is laid flat on the housing ground at both ends of the cable. Any electromagnetic interference active here does not affect the measurement signal. Special electronic coding methods are used to protect the transmission path and the rotor from electromagnetic interference.

In the case of interference due to potential differences (compensating currents), operating-voltage zero and housing ground must be disconnected on the amplifier and a potential equalization line established between the stator housing and the amplifier housing (copper conductor, 10mm² wire cross-section).

If potential differences arise between the rotor and the stator on the machine, perhaps due to unchecked leakage, and this causes interference, it can usually be overcome by connecting the rotor directly to earth, for instance by a wire loop. The stator should be fully earthed in the same way.

5.3 Option 2, code KF1

The stator housing has a 7-pin (Binder 723) male device connector, to which you link the connection cable for voltage supply and torque signal.

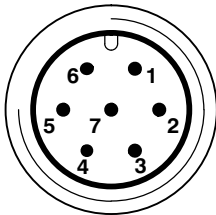
 <p>Binder 723</p> <p>Top view</p>	Connector Binder pin	Pin assignment	Wire color	MS3106 connect or pin
	1	Zero operating voltage	wh	A
	2	No function	bk	B
	3	Pre-supply voltage (+15 V)	bu	C
	4	Torque measurement signal (12 V _{PP} ; 5...15 kHz)	rd	D
	5	No function		
	6	Rotor excitation voltage (54 V/80 V _{PP} ; approx.15 kHz)	gn	F
	7	Rotor excitation voltage (0 V)	gy	G
		Shielding connected to enclosure ground		

5.3.1 Adaptation to the cable length

The transmission method between the rotor and the stator determines the function of the torque flange, which is dependent on:

- the installation situation (for example, covering, area free of metal parts)
- the length of the cable
- the tolerances of the excitation voltage supply

To allow for adaptation to the various conditions, there are three switches in the stator housing, which can be accessed by removing the stator cover (see Fig. 5.1).

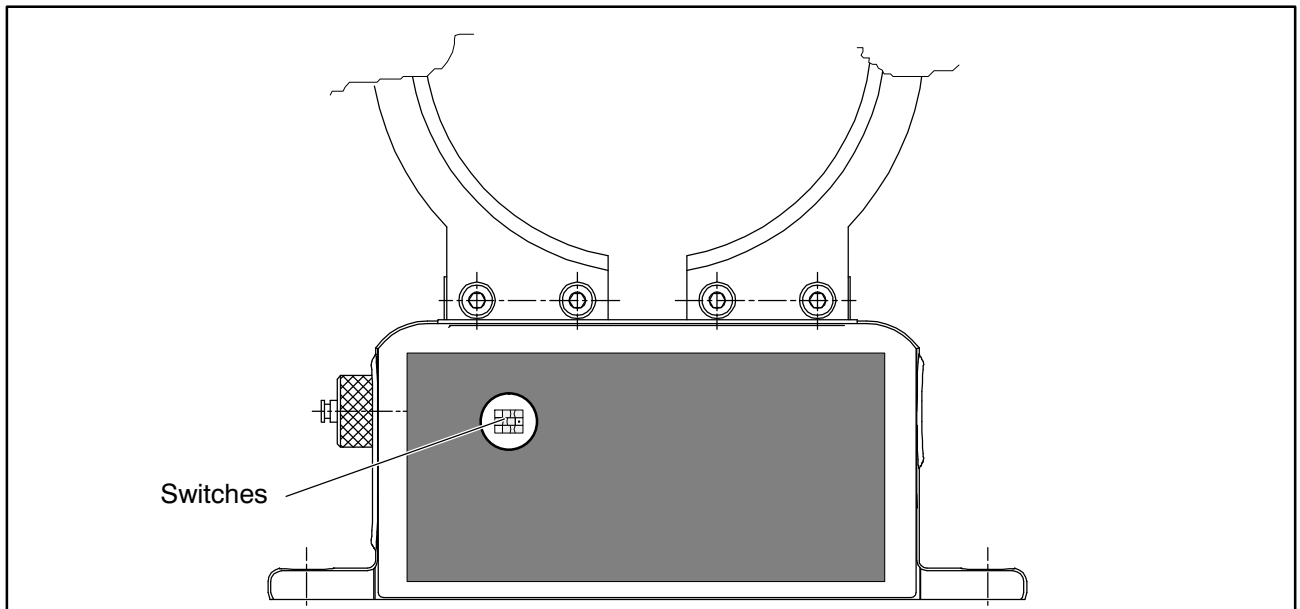





Fig. 5.1: Switches in the stator housing

Switch position		Application examples
1		a) Older amplifiers b) For when the calibration signal is unintentionally initiated with very short cables
2		Normal position (factory default)
3		For cable lengths in excess of approx. 20 m

Please ensure that after changing to switch position 3, the calibration signal is not initiated.

Possible faults and their elimination:

Fault: No signal at the output, amplifier indicates overflow.

Cause: Too little power, T10FS disconnects.

Remedy: Switch position 3.

Fault: The calibration signal has been triggered by mistake.

Remedy: Switch position 1.





5.4 Option 2, code SF1/SU2

On the stator housing, there are two 7-pin male device connectors (Binder 723) and in the case of the speed module option, there is also an 8-pin male device connector, assigned in accordance with the selected option.

The supply voltage and the calibration signal of plugs 1 and 3 are direct-coupled via multifuses (automatically resetting fuses).

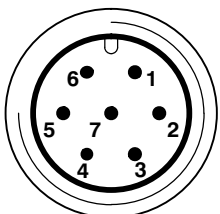
Assignment for plug 1:

Voltage supply and frequency output signal.

Binder 723  Top view	Connector Binder pin	Pin assignment	Wire color	Sub-D connec- tor pin
	1	Torque measurement signal (frequency output; 5V ¹⁾ ; /0 V) 	wh	13
	2	Supply voltage 0 V; 	bk	5
	3	Supply voltage 18 V ... 30 V	bu	6
	4	Torque measurement signal (frequency output; 5 V ¹⁾ /12 V)	rd	12
	5	Measurement signal 0 V; symmetrical 	gy	8
	6	Calibration signal trigger 5 V - 30 V	gn	14
	7	Calibration signal 0 V 	gy	8
		Shielding connected to enclosure ground		



¹⁾ Factory default; complementary signals RS-422



CAUTION

The torque flanges of option 3, code SF1/SU2 are only intended for operation with a DC supply voltage. They must not be connected to older HBM measuring amplifiers with square-wave excitation. This could lead to the destruction of the connection board resistances, or other errors in the measuring amplifiers (the torque flange, on the other hand, is protected and once the proper connections have been re-established, is ready for operation again).

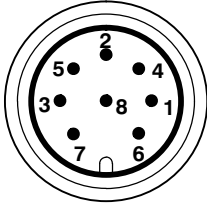

Assignment for plug 2: Speed measuring system

 <p>Binder 723</p> <p>Top view</p>	Connector Binder pin	Pin assignment	Wire color	Sub-D connector pin
	1	Speed measurement signal (pulse string, 5 V ¹); 0 °)	rd	12
	2	No function	-	-
	3	Speed measurement signal (pulse string, 5 V ¹); 90 °out-of-phase) ²⁾	gy	15
	4	No function	-	-
	5	No function	-	-
	6	Speed measurement signal (pulse string, 5 V ¹); 0 °)	wh	13
	7	Speed measurement signal (pulse string, 5 V ¹); 90 °out-of-phase) ²⁾	gn	14
	8	Zero operating voltage 	bk	8
		Shielding connected to enclosure ground		-

1) Complementary signals RS-422

2) When switching to double frequency, static direction of rotation signal.

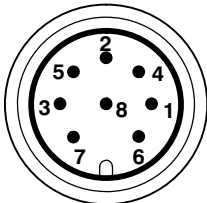
Assignment for plug 2: Speed measuring system with reference pulse





 <p>Binder 723</p> <p>Top view</p>	Connector Binder pin	Pin assignment	Wire color
	1	Speed measurement signal (pulse string, 5 V ¹); 0 °)	rd
	2	Reference signal (1 pulse/rev., 5 V ¹)	bu
	3	Speed measurement signal (pulse string, 5 V ¹); 90 °out-of-phase) ²⁾	gy
	4	Reference signal (1 pulse/rev., 5 V ¹)	bk
	5	No function	
	6	Speed measurement signal (pulse string, 5 V ¹); 0 °)	wh
	7	Speed measurement signal (pulse string, 5 V ¹); 90 °out-of-phase) ²⁾	gn
	8	Zero operating voltage 	ye
		Shielding connected to enclosure ground	

1) Complementary signals RS-422

2) When switching to double frequency, static direction of rotation signal.

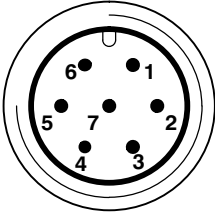
Assignment for plug 3:

Voltage supply and voltage output signal.

 <p>Binder 723</p> <p>Top view</p>	Connector Binder pin	Pin assignment
	1	Torque measurement signal (voltage output; 0 V) 
	2	Supply voltage 0 V; 
	3	Supply voltage 18 V ... 30 V DC
	4	Torque measurement signal (voltage output; ± 10 V)
	5	No function
	6	Calibration signal trigger 5 V - 30 V
	7	Calibration signal 0 V; 
		Shielding connected to enclosure ground

5.5 Supply voltage

The transducer has to be operated with a separated extra low voltage (18...30 V DC supply voltage) which usually feeds one or several consumers in a test bench.

If the device is to be used in a DC voltage network¹⁾, additional measures have to be taken to ensure that over-voltages are discharged.

The notes in this chapter refer to standalone operation of the T10F without HBM system solutions.

The supply voltage is galvanically isolated from signal outputs and calibration signal inputs. Connect an extra-low safe voltage of 18 V...30 V to pin 3 (+) and pin 2 (⊖) of connector 1 or connector 3. We recommend that you use HBM cable KAB 8/00-2/2/2 and the appropriate connector jacks, since when operated at nominal voltage (24 V) the cable can be up to 50 m long, or 20 m long if within the nominal voltage range (see Accessories, page 63) . If the permitted cable length is exceeded, you may supply the required voltage over two cables connected in parallel (connectors 1 and 3). This enables you to double the permitted length. Alternatively an on-site power pack should be installed.

If you feed the supply voltage through an unshielded cable, the cable must be twisted (interference suppression). We also recommend that a ferrite element should be located close to the connection plug on the cable, and the stator should be earthed.



CAUTION

At the instant of switching on, a current of up to 2 A may flow and this may switch off power packs with electronic current limiters.

¹⁾ Distribution system for electrical energy over a wide area (e.g. over several test benches) which possibly also supplies consumers with high nominal (rated) currents.

6 Calibration

T10FS torque flanges deliver an electrical calibration signal that can be switched at the amplifier end for measurement chains with HBM components. The measurement flange generates a calibration signal of about 50 % of the nominal (rated) torque. The precise value is specified on the identification plate. Adjust the amplifier output signal to the calibration signal supplied by the connected torque flange to adapt the amplifier to the measurement flange. To obtain stable conditions, the calibration signal should only be activated once the transducer has been warming up for 15 minutes.

Hinweis:



The measurement flange should not be under load when the calibration signal is being measured, since the calibration signal is mixed additively.



CAUTION

To maintain measurement accuracy, the calibration signal should be connected for no more than 5 minutes. A similar period is then needed as a cooling phase before triggering the calibration signal again.

6.1 Calibration Option 2, code KF1

Increasing the excitation voltage from 54 V_{PP} to 80 V_{PP} (pins 6 and 7, plug 1), triggers the calibration signal.

6.2 Calibration Option 2, code SF1/SU2

Applying a separated extra-low voltage of 5 V to pin 6 (+) and 7 () on plug 1 or 3 triggers the calibration signal.

The nominal (rated) voltage for triggering the calibration signal is 5 V (triggered when $U > 2.7$ V). The trigger voltage is electrically isolated from the supply voltage and the measurement voltage. The maximum permissible voltage is 30 V. When voltages are less than 0.7 V, the torque flange is in measuring mode. Current consumption at nominal (rated) voltage is approx. 2 mA and at maximum voltage is approx. 22 mA.

Hinweis:

 In the case of HBM system solutions, the measuring amplifier triggers the calibration signal.

7 Settings

Hinweis:

You will find a table containing all the relevant switch positions on the back of the stator cover. Changes to the factory settings should be marked or noted here using a waterproof felt-tip pen.

Einstellungen / Settings- OPTION 5																																												
Impulse/Umdrehungen Pulses/rotation	360	180	90	60	30	15	720																																					
M_{nom} (N·m) to 3 kN·m								WERKSEINSTELLUNG Factory settings Eigene Einstellungen Customized settings																																				
	<input checked="" type="checkbox"/> <input type="checkbox"/>	<input type="checkbox"/> <input type="checkbox"/>	<input type="checkbox"/> <input type="checkbox"/>	<input type="checkbox"/> <input type="checkbox"/>	<input type="checkbox"/> <input type="checkbox"/>	<input type="checkbox"/> <input type="checkbox"/>																																						
M_{nom} 5 kN·m to 10 kN·m								ON DIP <table border="1"> <tr><td></td><td></td><td></td><td></td><td></td><td></td></tr> <tr><td></td><td></td><td></td><td></td><td></td><td></td></tr> <tr><td></td><td></td><td></td><td></td><td></td><td></td></tr> <tr><td></td><td></td><td></td><td></td><td></td><td></td></tr> <tr><td></td><td></td><td></td><td></td><td></td><td></td></tr> <tr><td></td><td></td><td></td><td></td><td></td><td></td></tr> </table> 1 2 3 4 5 6																																				
	<input checked="" type="checkbox"/> <input type="checkbox"/>	<input type="checkbox"/> <input type="checkbox"/>	<input type="checkbox"/> <input type="checkbox"/>	<input type="checkbox"/> <input type="checkbox"/>	<input type="checkbox"/> <input type="checkbox"/>	<input type="checkbox"/> <input type="checkbox"/>	<input type="checkbox"/> <input type="checkbox"/>																																					
+ - Hysterese Hysteresis	ein / on <input checked="" type="checkbox"/>			aus / off <input type="checkbox"/>																																								
Frequenz Ausgangsspannung Frequency output voltage	CH1 CH2			CH1 2 x f CH2																																								
	<input checked="" type="checkbox"/>			<input type="checkbox"/>																																								

Fig. 7.1: Sticker with switch positions; optical speed measuring system

Einstellungen/ Settings OPTION 5, Code M																													
M_{nom}	Pole pro Umdrehung Magnetic poles per revolution	Auswertefaktor Evaluation factor																											
		1 <input type="checkbox"/>	4 <input type="checkbox"/>	5 <input type="checkbox"/>	8 <input type="checkbox"/>	10 <input type="checkbox"/>																							
		Impulse/Umdrehung Pulses/revolution																											
100 N·m–200 N·m	120	<input type="checkbox"/>	<input type="checkbox"/>	<input checked="" type="checkbox"/> 600	<input type="checkbox"/>	<input type="checkbox"/>																							
500 N·m–1 kN·m	144	<input type="checkbox"/>	<input type="checkbox"/>	<input checked="" type="checkbox"/> 720	<input type="checkbox"/>	<input type="checkbox"/>																							
2 kN·m–10 kN·m	180	<input type="checkbox"/>	<input checked="" type="checkbox"/> 720	<input type="checkbox"/>	<input type="checkbox"/>	<input type="checkbox"/>																							
Ausgangsimpulsteilung Output pulse division		1	2	4	6	12																							
		<input checked="" type="checkbox"/>	<input type="checkbox"/>	<input type="checkbox"/>	<input type="checkbox"/>	<input type="checkbox"/>																							
 Hysteresese Hysteresis	<input type="checkbox"/> on <input checked="" type="checkbox"/> ein	<input type="checkbox"/> off <input type="checkbox"/> aus	Frequenz- Ausgangsspannung Frequency output voltage	<input checked="" type="checkbox"/> CH1 <input type="checkbox"/> CH2	<input type="checkbox"/> CH1 <input type="checkbox"/> CH2	 2 x f																							
	<div style="display: flex; justify-content: space-between;"> <div style="text-align: center;"> WERKSEINSTELLUNG Factory settings <input checked="" type="checkbox"/> </div> <div style="text-align: center;"> Eigene Einstellungen Customized settings <input type="checkbox"/> </div> </div> ON DIP <table border="1" style="margin-left: auto; margin-right: auto;"> <tr><td> </td><td> </td><td> </td><td> </td><td> </td><td> </td></tr> <tr><td> </td><td> </td><td> </td><td> </td><td> </td><td> </td></tr> <tr><td> </td><td> </td><td> </td><td> </td><td> </td><td> </td></tr> <tr><td> </td><td> </td><td> </td><td> </td><td> </td><td> </td></tr> </table> 1 2 3 4 5 6																												

Fig. 7.2: Sticker with switch positions; magnetic speed measuring system

Refer to Table 7.3 (page 48) for all pulse counts that can be adjusted with the magnetic speed measuring system. Please make note of all changes to the factory settings on the sticker.

7.1 Torque output signal, code KF1

The factory setting for the frequency output voltage is 12 V (asymmetrical). The frequency signal is on pin 4 opposite pin 1. It is not possible to change over.

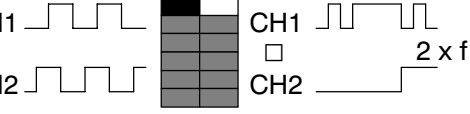
7.2 Torque output signal, code SF1/SU2

The factory setting for the frequency output voltage is 5 V (symmetrical, complementary RS422 signals). The frequency signal is on pin 4 opposite pin 1. You can change the output voltage to 12 V (asymmetrical). To do this, change switches S1 and S2 to position 1 (and pin 1 → ).

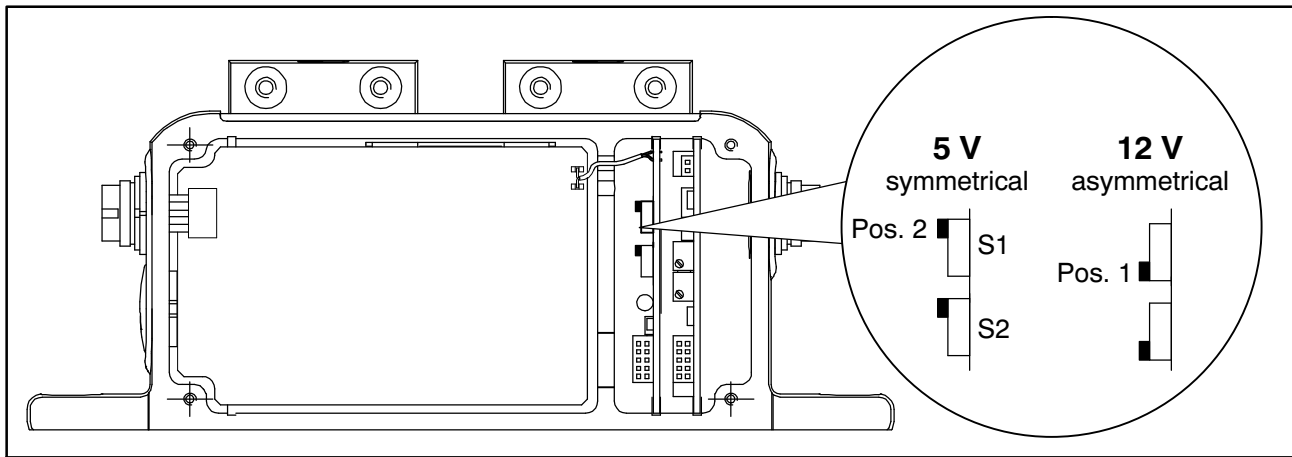

Fig. 7.3: Switch for changing the frequency-output voltage

7.3 Setting up the zero point

In the case of the torque flange with the voltage output option (SU2), you can access two potentiometers by removing the stator cover. You can use the zero point potentiometer to correct certain zero point deviations. The balancing range is a minimum of ± 400 mV at nominal (rated) gain. The end point potentiometer is used for compensation at the factory and is capped with varnish so that it cannot be turned unintentionally.



CAUTION

Turning the end point potentiometer changes the factory calibration of the voltage output.

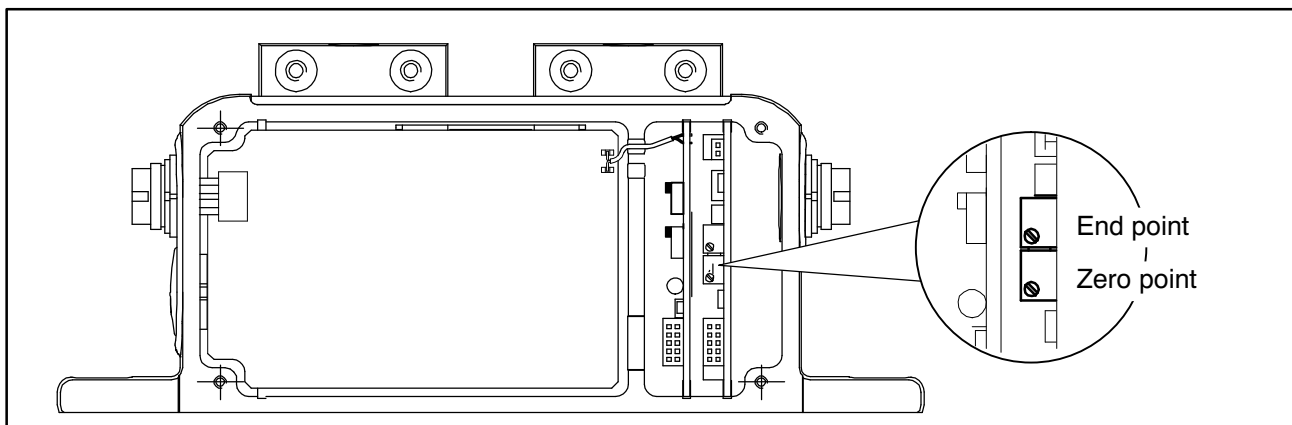

Fig. 7.4: Setting up the voltage output zero point

7.4 Functional testing

7.4.1 Power transmission

If you suspect that the transmission system is not working properly, you can remove the stator cover and test for correct functioning. If the LED is on, the rotor and stator are properly aligned and there is no interference with the transmission of measuring signals. When the calibration signal is triggered, the LED shines more brightly.

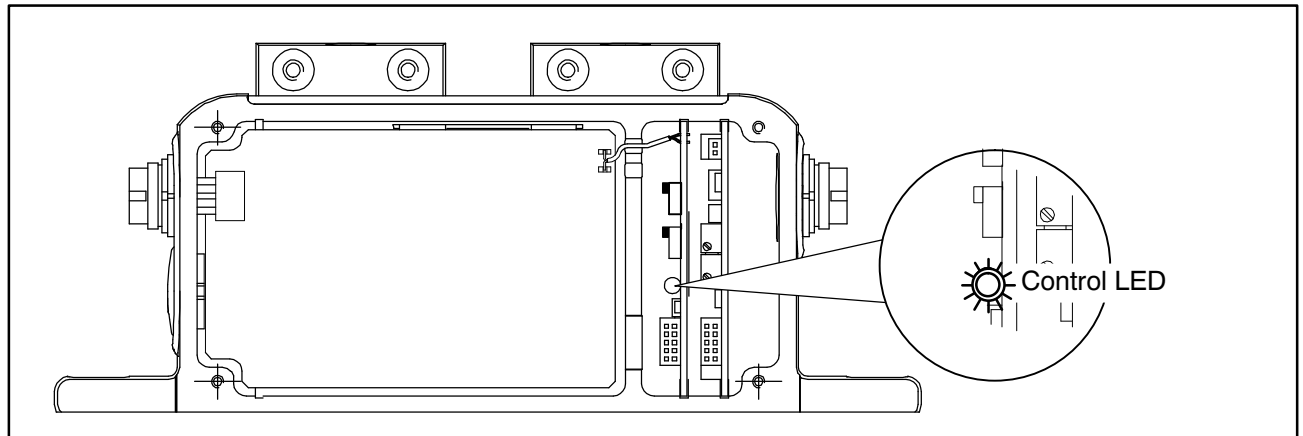

Fig. 7.5: Functional test for power transmission

7.4.2 Testing the optical speed module

When required, you can test the correct functioning of the speed measuring system.

1. Remove the cover of the stator housing.
2. Turn the rotor by at least 2 min^{-1} .

If both the control LEDs come on while you are turning the rotor, the speed measuring system is properly aligned and fully operational.

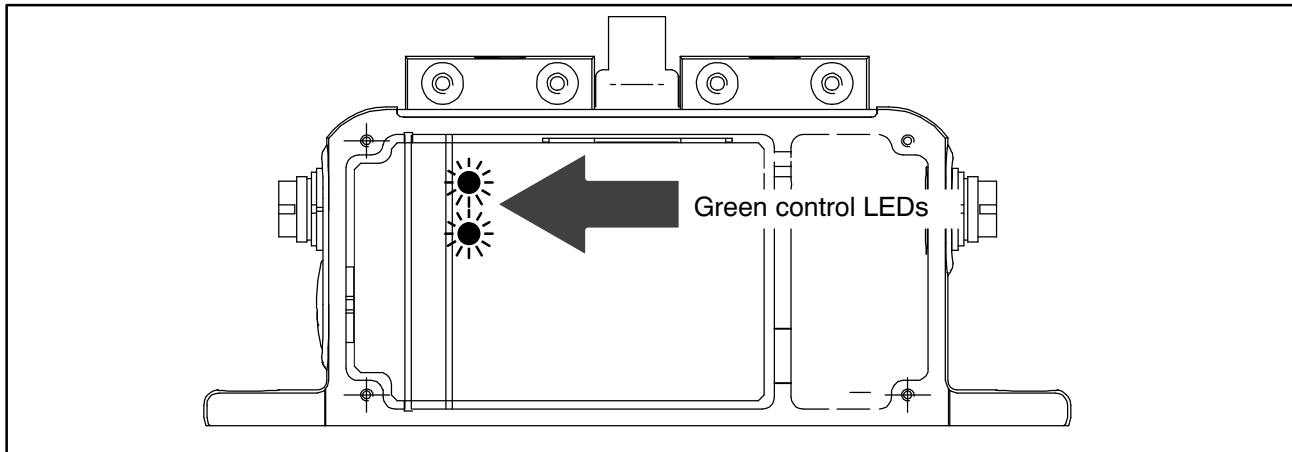

Fig. 7.6: Control LEDs of the speed measuring system



CAUTION

When closing the cover of the stator housing, make sure that the internal connection cables are positioned in the grooves provided and are not caught up.

7.5 Setting the pulse count

7.5.1 Magnetic speed measuring system

With the magnetic speed measuring system, a magnetized rotor is sampled by means of an MR sensor (magnetoresistive sensor). The sensor produces two sinusoidal signals offset by 90°, from which up to 10 evaluation points can be generated per pole (can be adjusted with switches F1 ... F3). The output pulses can again be divided by means of the subsequent electronic system (switches S1 ... S4), thus making available a greater selection of output pulse counts per revolution (see Table 7.3).

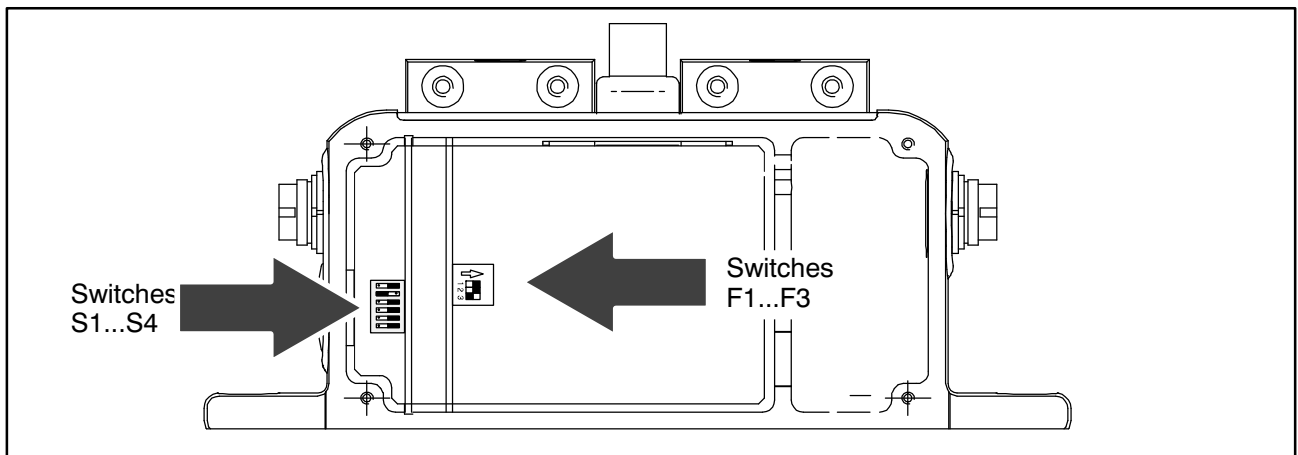

Fig. 7.7: Setting the pulse count; magnetic speed measuring system

M_{nom}	Pole pro Umdrehung Magnetic poles per revolution	Auswertefaktor Evaluation factor					WERKSEINSTELLUNG Factory settings ● Eigene Einstellungen Customized settings □
		1	4	5	8	10	
100 N·m–200 N·m	120	<input type="checkbox"/>	<input type="checkbox"/>	<input checked="" type="checkbox"/> 600	<input type="checkbox"/>	<input type="checkbox"/>	ON DIP 1 2 3 4 5 6
500 N·m–1 kN·m	144	<input type="checkbox"/>	<input type="checkbox"/>	<input checked="" type="checkbox"/> 720	<input type="checkbox"/>	<input type="checkbox"/>	
2 kN·m–10 kN·m	180	<input type="checkbox"/>	<input checked="" type="checkbox"/> 720	<input type="checkbox"/>	<input type="checkbox"/>	<input type="checkbox"/>	

Table 7.1: Evaluation points per pole (● = factory default)

Output pulse division (6-fold DIP switches)	1	2	4	6	12

Table 7.2: Switch settings for output pulse division (● = factory default)

Output pulses/revolution			Switch setting	
100 N·m/200 N·m	500 N·m/1 kN·m	2 kN·m ... 10 kN·m	S1 ... S4	F1 ... F3
10	12	15		
20	24	30		
30	36	45		
40	48	60		
50	60	75		
60	72	90		
80	96	120		
100	120	150		
120	144	180		
150	180	225		
160	192	240		
200	240	300		
240	288	360		
300	360	450		
480	576	720 ^{*)}		
600 ^{*)}	720 ^{*)}	900		
960	1152	1440		
1200	1440	1800		

Table 7.3: Switch settings for pulse count/revolution (■ \triangle switch lever)

^{*)} Factory default

The output pulse count is calculated according to the following formula:

$$\text{Output pulse count} = \frac{\text{magnetic poles} \cdot \text{eval. points per pole}}{\text{output pulse division}}$$

Hinweis:

 Please make sure that when you change the pulse count, you also change the pulse duration!

We recommend giving preference to the output pulse counts selected by switches F1 ... F3. By using pulse division (switches S1 ... S4), it is possible to increase the pulse tolerance stated in the specifications. Other quantities, such as the eccentricity and the relative movement between the rotor and the stator can affect the pulse tolerance.

7.5.2 Optical speed measuring system

Hinweis:

 The factory setting is 360 pulses/revolution. Please make sure that when you change the pulse count, you also change the pulse duration!

$$\text{Pulse duration} = \frac{1}{2 \cdot \text{pulse count} \cdot \text{speed}}$$

The number of pulses per revolution of the rotor can be adjusted by means of DIP switches S1...S4.

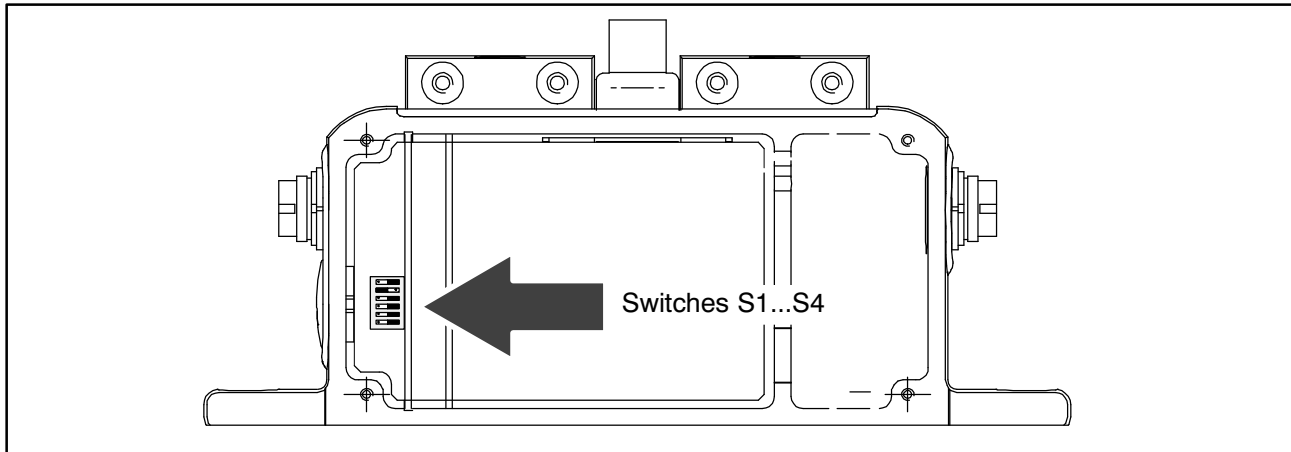

Fig. 7.8: Switches for setting the pulse count

Setting the pulse count

1. Remove the stator cover.
2. Use switches S1...S4 in accordance with Table 7.4 to set the required pulse count.







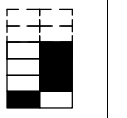
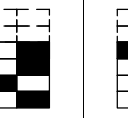
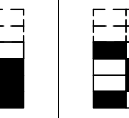

Pulses/revolution	360 ¹⁾	180	90	60	30	15	720
Nominal (rated) torque 100 N·m ... 3 kN·m							
Nominal (rated) torque 5 kN·m ... 10 kN·m							

Table 7.4: Switch settings for the pulse count (■ \triangle switch lever)

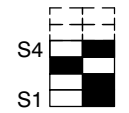
¹⁾ Factory default

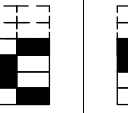
7.6 Vibration suppression (hysteresis)

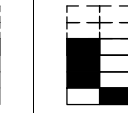
Low rotation speeds and higher relative vibrations between the rotor and the stator can cause disturbance signals that reverse the direction of rotation. Electronic suppression (hysteresis) to eliminate these disturbances is connected at the factory. Disturbances caused by the radial stator vibration amplitude and by the torsional vibration of the rotor are suppressed.

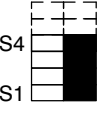
Vibration suppression		Speed measuring system	
		magnetic	optical
Radial vibration amplitude of stator, approx.	mm	1	2
Torsional vibration of rotor, approx.	deg.	1	2

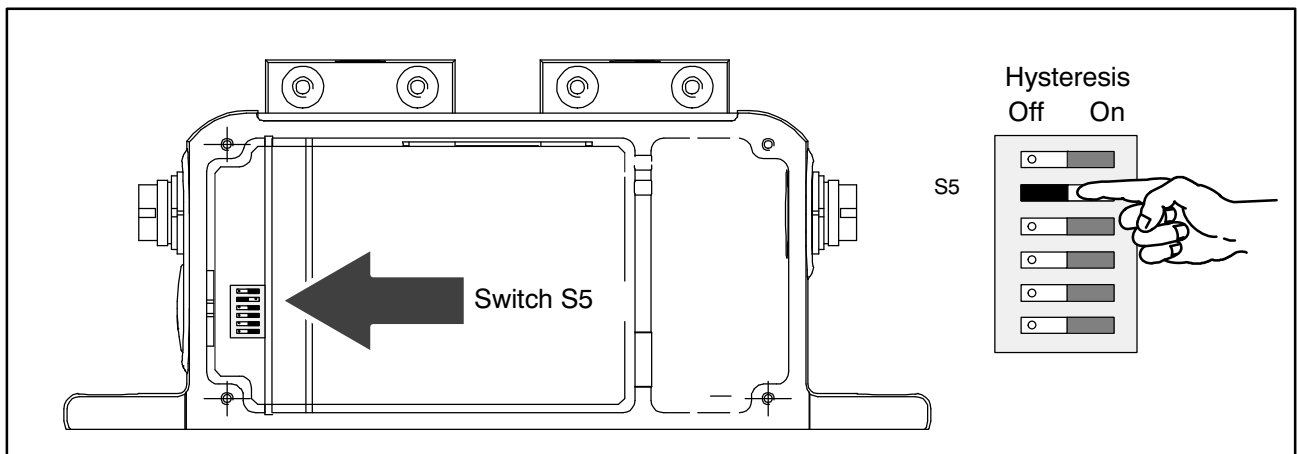

Fig. 7.9: Switch for switching off hysteresis

7.7 Form of the rotation speed output signal

In the factory settings, two 90° phase-offset speed signals (5 V symmetrical, complementary RS422 signals) are available. You can double the pulse count set in each case by moving switch S6 to the "On" position. Pin 3 then outputs the direction of rotation as a static direction of rotation signal (pin 3 = +5 V, pin 7 = 0 V opposite pin 8), if the shaft turns in the direction of the arrow. At a rotation speed of 0 min⁻¹, the direction of rotation signal has the last measured value.

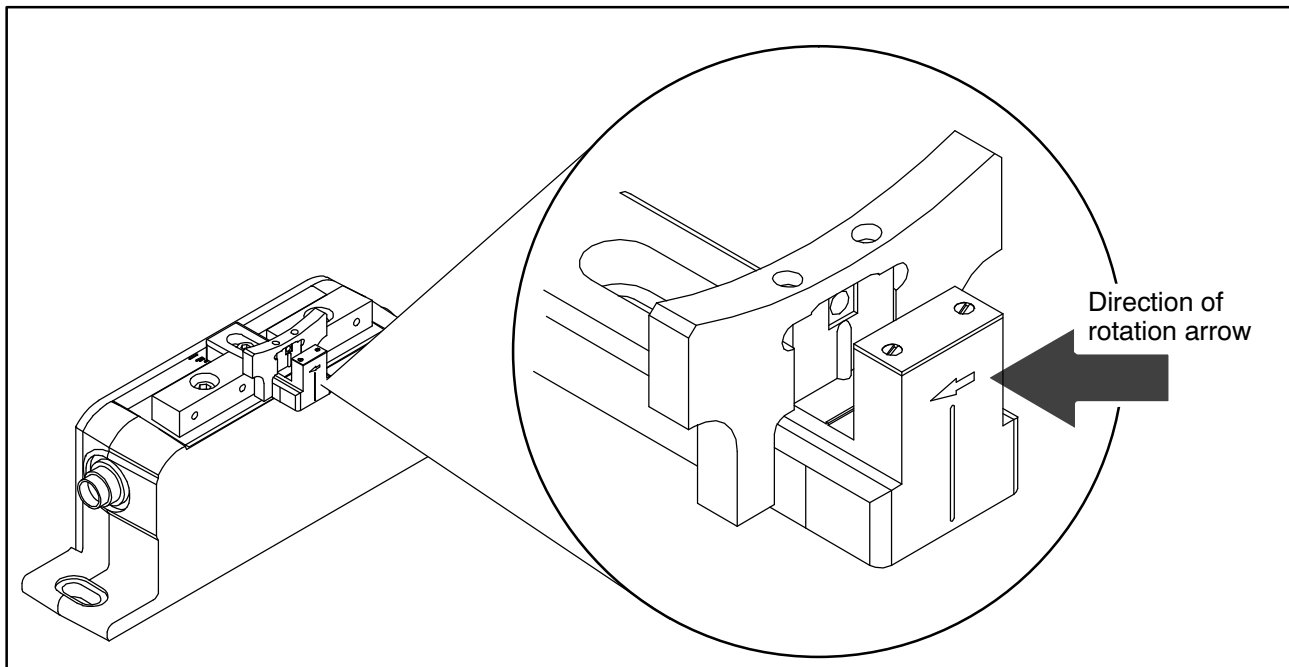

Fig. 7.10: Direction of rotation arrow on the head of the sensor

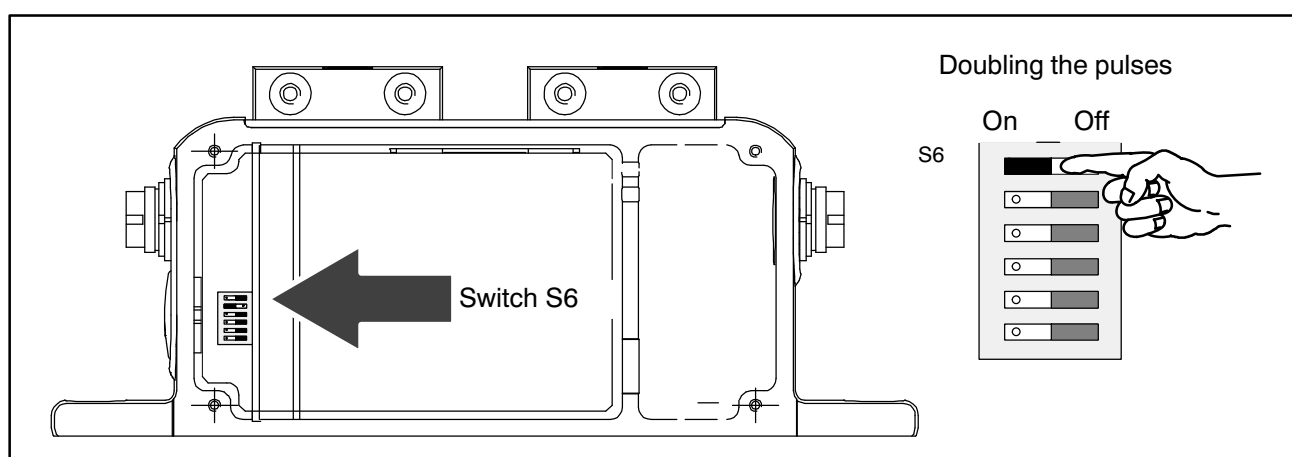

Fig. 7.11: Switch for doubling the pulses

7.8 Type of the rotation speed output signal

You can use switch S7 to change the symmetrical 5 V output signal (factory setting) to an asymmetrical signal of 0 V ... 5 V.

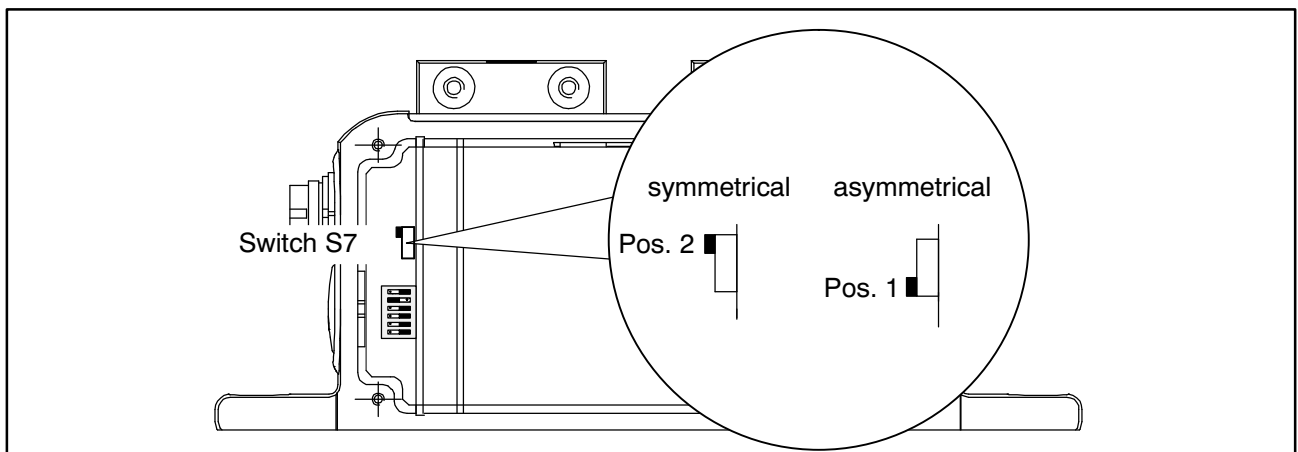

Fig. 7.12: Switch S7; symmetrical/asymmetrical output signal

7.9 Optical speed measuring system with a reference pulse

In the case of the reference pulse option, a magnet is integrated into the slotted disc of the speed measuring system, that generates a pulse at each full revolution of the rotor. The pulse can be picked up at switch 2 (see Page 37).

The reference pulse is synchronized with the rotation speed output signal (5 V^1 , 0°) and is output if the reference marker is passed and a rising edge occurs during the rotation speed signal.

The pulse length corresponds to the length of a speed increment, which depends on the chosen pulse count and speed (for the calculation, see Page 47).

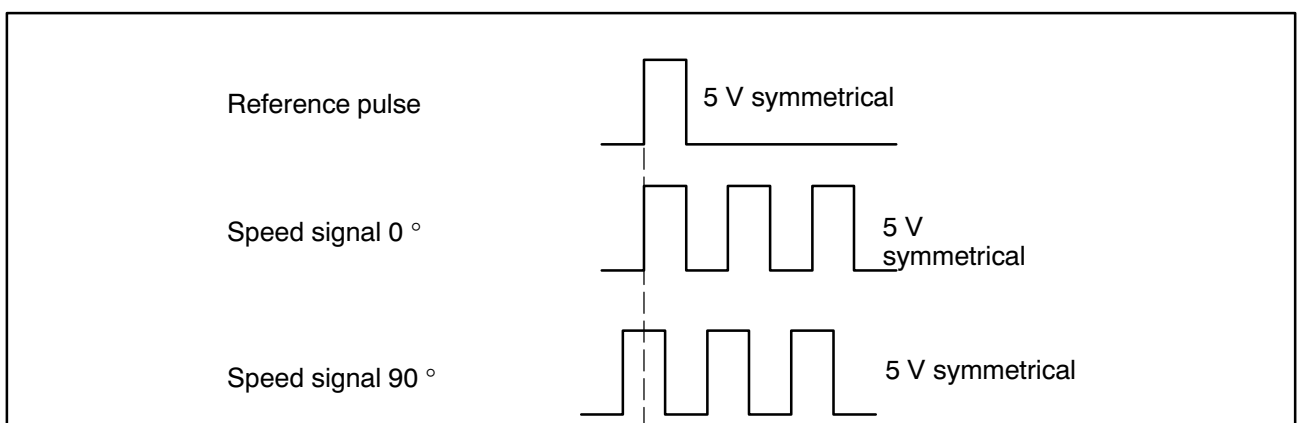

Fig. 7.13: Electrical condition of the reference pulse

¹⁾ Complementary signals RS-422

When the speed measuring system and the reference pulse are properly synchronized, LED L4 flashes (minimum speed 2 min^{-1}) and stays on from approx. 1000 min^{-1} . If the LED is **not** on, please change switch S8 (see Fig. 7.14).



CAUTION

When viewed from above, switch S8 is behind switch S7 in the opened stator housing.

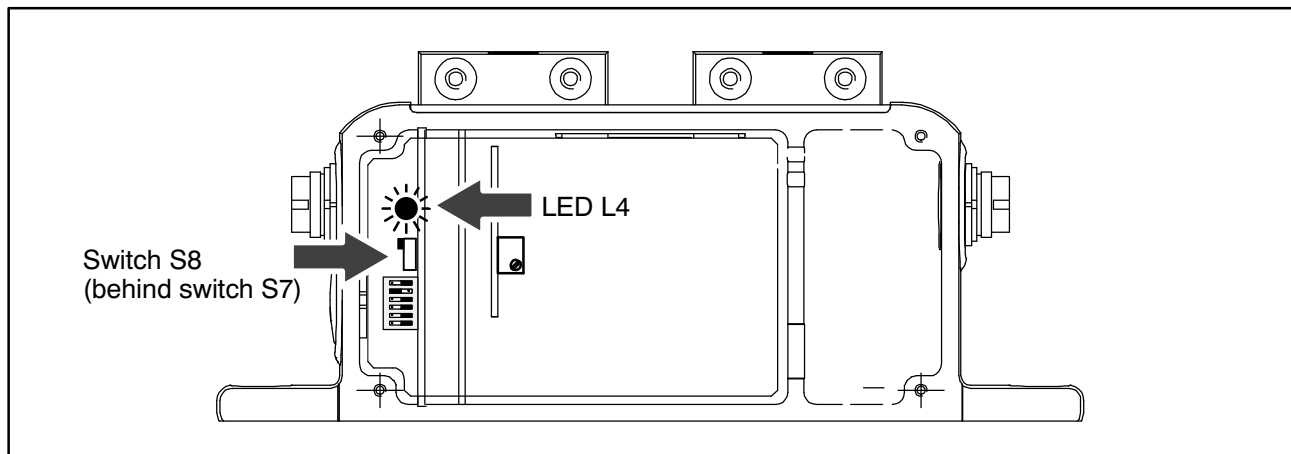

Fig. 7.14: Switch S8; optimizing the reference pulse

8 Loading capacity

Nominal (rated) torque can be exceeded statically up to the limit torque. If nominal (rated) torque is exceeded, additional irregular loading is not permissible. This includes longitudinal forces, lateral forces and bending moments. Limit values can be found in the "Specifications" section, Page 64.

8.1 Measuring dynamic torque

The torque flanges can be used to measure static and dynamic torques. The following applies to the measurement of dynamic torque:

- The T10FM calibration made for static measurements is also valid for dynamic torque measurements.
- The natural frequency f_0 for the mechanical measuring system depends on the moments of inertia J_1 and J_2 of the connected rotating masses and the T10FM's torsional stiffness.

Use the equation below to approximately determine the natural frequency f_0 for the mechanical measuring system:

$$f_0 = \frac{1}{2\pi} \cdot \sqrt{c_T \cdot \left(\frac{1}{J_1} + \frac{1}{J_2} \right)}$$

f_0 = natural frequency in Hz
 J_1, J_2 = mass moment of inertia in kg·m²
 c_T = torsional stiffness in N·m/rad

- The mechanical vibration bandwidth (peak-to-peak) must be no more than 200 % (measuring range 100 N·m 400 %; measuring range 3 ... 10 kN·m 160 %) of the nominal (rated) torque identified for the T10FS. The vibration bandwidth must fall within the loading bandwidth specified by $-M_{nom}$ and $+M_{nom}$ (at 100 N·m: $-2 M_{nom}$ and $+2 M_{nom}$ ^{*)}). The same also applies to transient resonance points.

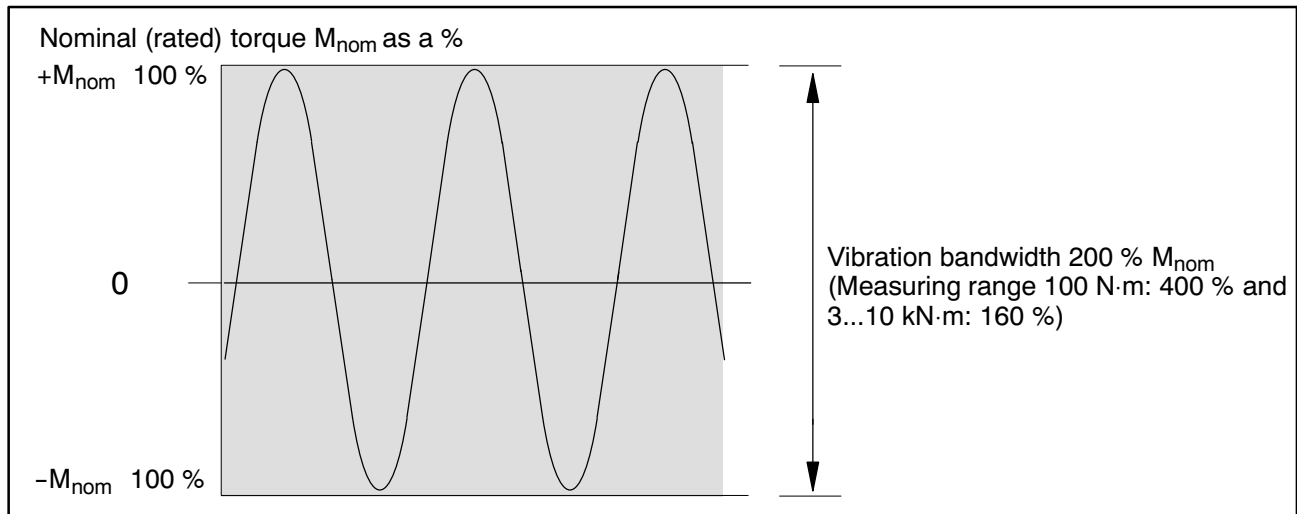

Fig.8.1: Permissible dynamic loading

^{*)} Metrologically, however, the transducers can only be used up to the control range.

9 Maintenance

9.1 Torque flange maintenance

The speed measuring system is maintenance-free.

9.2 Speed module maintenance

9.2.1 Magnetic speed measuring system

The sensor head and the pole ring contain plastic components. You can clean these with a dry or spirit-impregnated cotton bud or cloth. Do not use any other solvent!

9.2.2 Optical speed measuring system

During operation and depending on the ambient conditions, the slotted disc of the rotor and the associated stator sensor optics can get dusty. This will become noticeable when the polarity of the display changes. Should this occur, the sensor and the slotted disc must be cleaned.

1. Use compressed air (up to 6 bar) to clean the slotted disc.
2. Clean the sensor optics carefully with a dry or spirit-impregnated cotton bud. **Other solvents!** Do not use any other solvents!

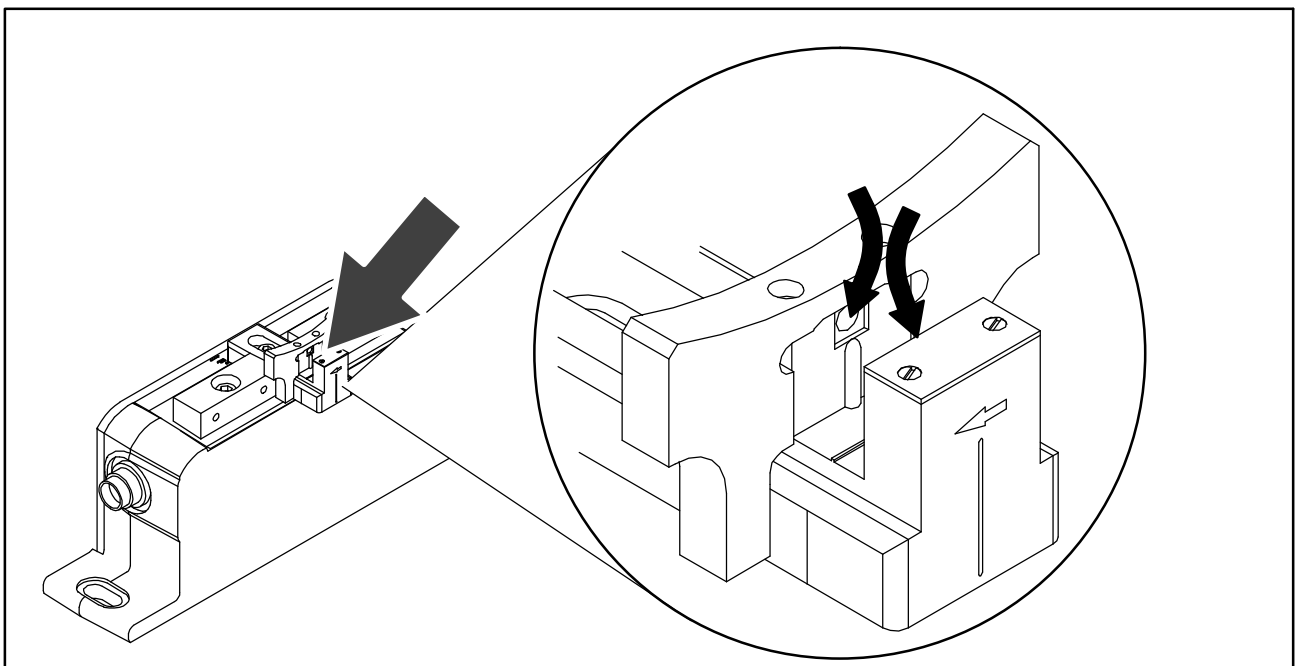
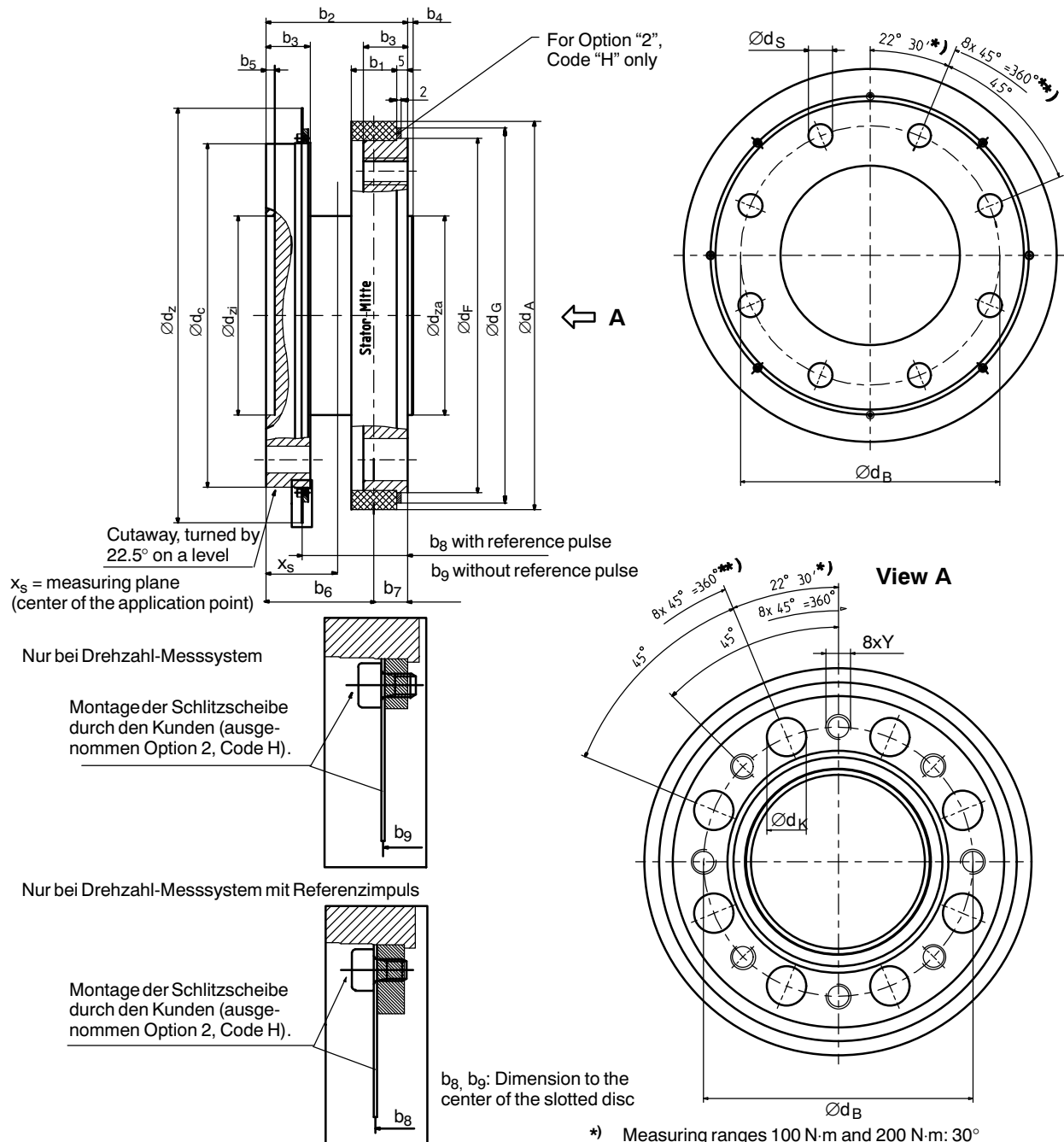

Fig.9.1: Cleaning points on the optical speed sensor

10 Dimensions

10.1 Rotor dimensions



Dimensions without tolerances, in accordance with DIN ISO 2768-mK

*) Measuring ranges 100 N·m and 200 N·m: 30°

**) Measuring ranges 100 N·m and 200 N·m: 60°, 6x60° = 360°

Measuring range	Dimensions (in mm)										
	b_1	b_2	b_3	$b_{4+0,4}$	b_5	b_6	b_7	b_8	b_9	x_s	Y
100 N·m / 200 N·m	17.5	60	18	2	4	46.3	13.7	47.2	47.2	30	M8
500 N·m / 1 kN·m	17.5	60	18	2	4	46.3	13.7	45.5	45	30	M10
2 kN·m / 3 kN·m	20.5	64	20	2,5	4	48.8	15.2	47.5	47	32	M12
5 kN·m	22.5	84	26	2,8	3	67.8	16.2	62.7	62.7	42	M14
10 kN·m	28.5	92	30	3,5	4	72.8	19.2	66.7	66.7	46	M16

Messbereich	Dimensions (in mm)										
	$\varnothing d_A$	$\varnothing d_B$	$\varnothing d_C$	$\varnothing d_F$	$\varnothing d_G$	$\varnothing d_K$	$\varnothing d_S^{C12}$	$\varnothing d_Z$	$\varnothing d_{za\ g5}$	$\varnothing d_{zi\ H6}$	
100 N·m / 200 N·m	119	84	99	101	110	14	8	131	57	57	
500 N·m / 1 kN·m	139	101,5	120	124	133	17	10	151	75	75	
2 kN·m / 3 kN·m	175	130	155	160	169	19	12	187	90	90	
5 kN·m	209	155,5	180	188	-	22	14	221	110	110	
10 kN·m	256	196	222	230	-	26	17	269	140	140	

10.2 Rotor dimensions with the magnetic speed system

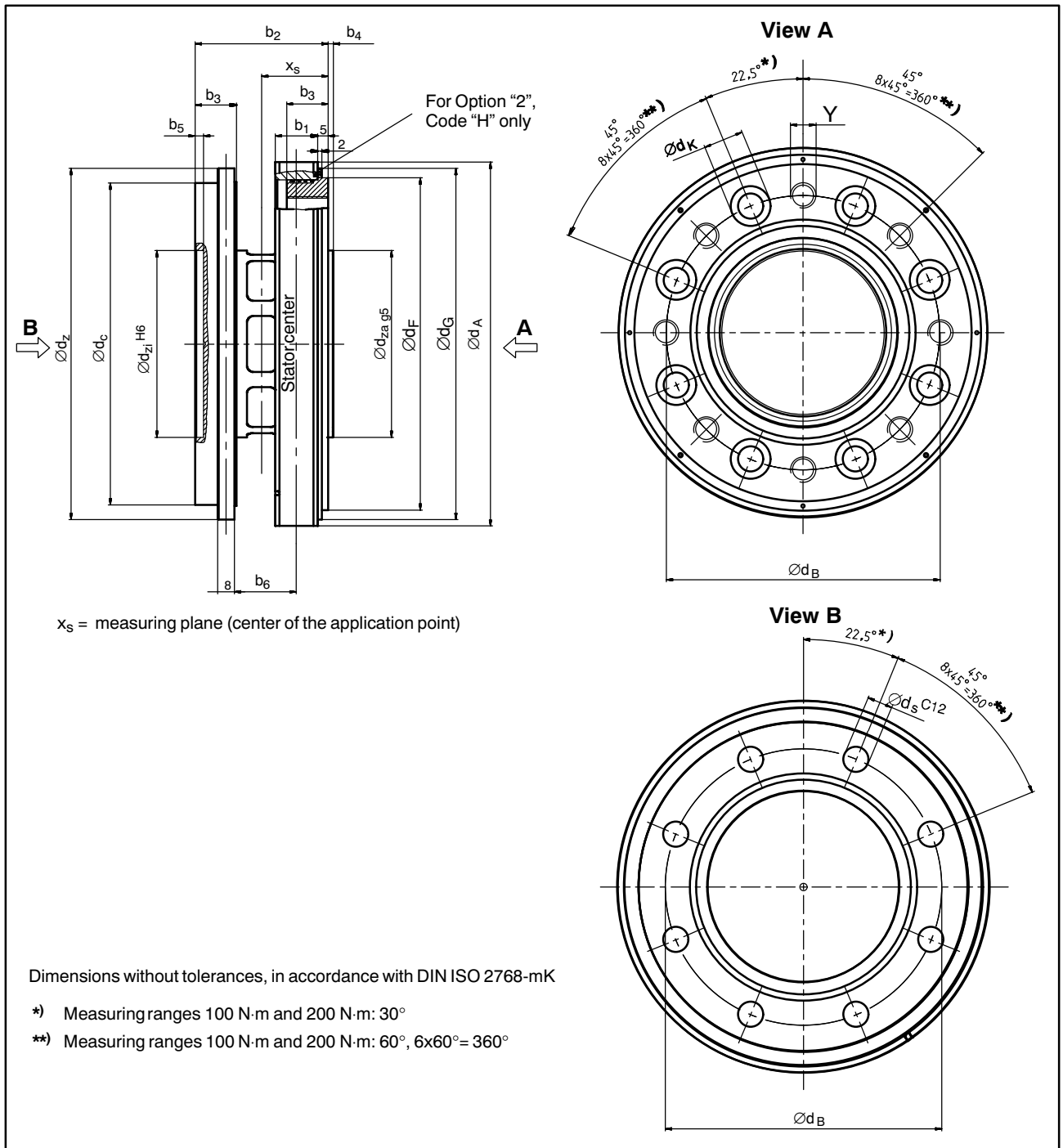

Measuring range	Dimensions (in mm)																	
	Ød _A	Ød _B	Ød _C	Ød _F	Ød _G	Ød _K	Ød _S	Ød _Z	Ød _{za}	Ød _{zi}	b ₁	b ₂	b ₃	b _{4+0.4}	b ₅	b ₆	x _S	Y
100 N·m 200 N·m	119	84	99	101	110	14	8	112.9	57	57	17.5	60	18	2	4	31	30	6xM8
500 N·m 1 kN·m	139	101.5	120	124	133	17	10	132.9	75	75	17.5	60	18	2	4	29	30	8xM10
2 kN·m 3 kN·m	175	130	155	160	169	19	12	168.9	90	90	20.5	64	20	2.5	4	30	32	8xM12
5 kN·m	209	155.5	180	188	-	22	14	192.5	110	110	22.5	84	26	2.8	3	44	42	8xM14
10 kN·m	256	196	222	230	-	26	17	239.7	140	140	28.5	92	30	3.5	4	45	46	8xM16

10.3 Stator dimensions

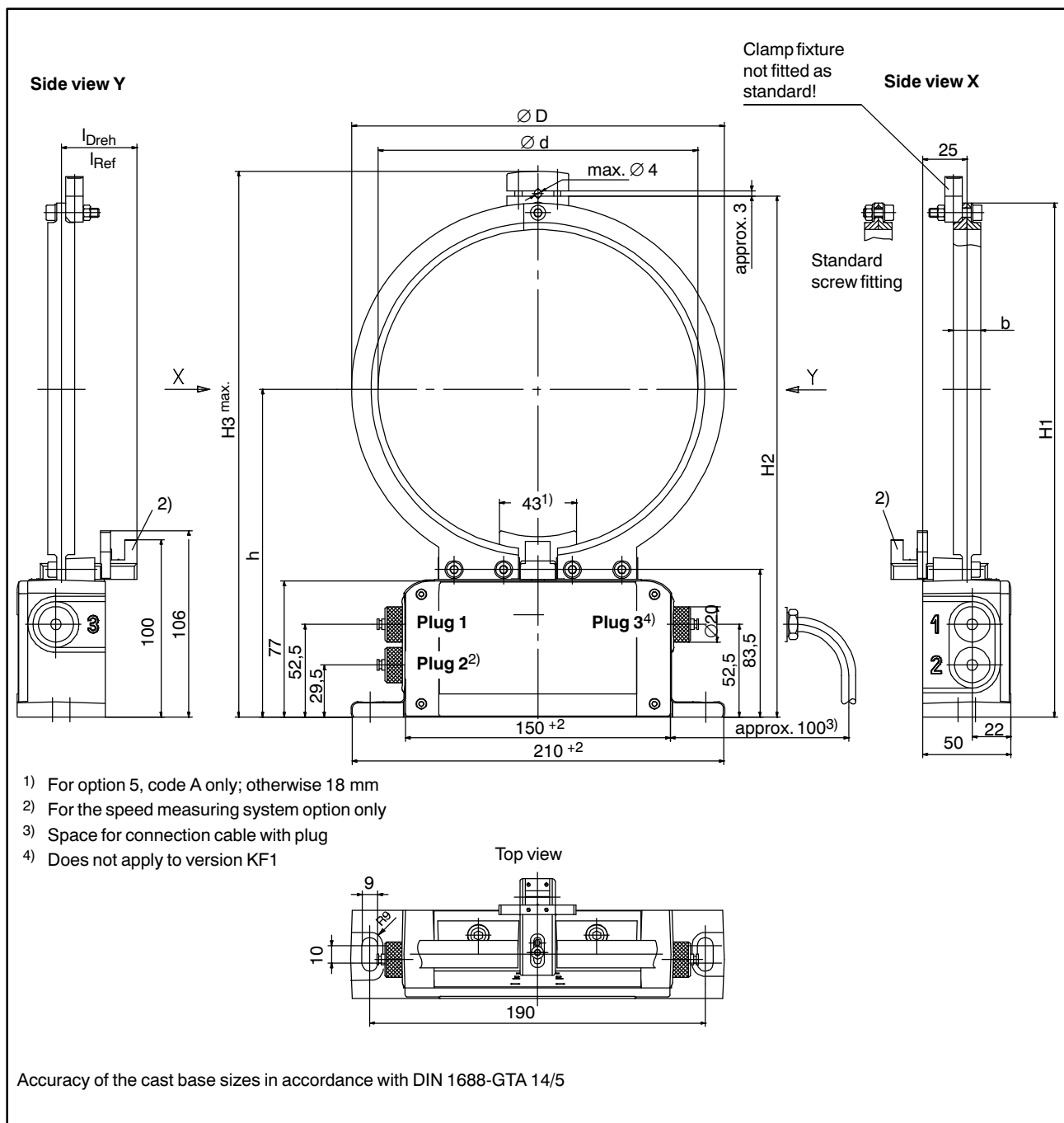

- 1) For option 5, code A only; otherwise 18 mm
- 2) For the speed measuring system option only
- 3) Space for connection cable with plug
- 4) Does not apply to version KF1

Measuring range	Dimensions (in mm)								
	b	∅ d	∅ D	H1	H2	H3	h	l _{Dreh}	l _{Ref}
100 N·m 200 N·m	17.5	125	155	235	239	253	157.5	42.5	42.5
500 N·m 1 kN·m	17.5	145	175	255	259	273	167.5	42	42.5
2 kN·m 3 kN·m	20.5	181	211	291	295	309	185.5	42.5	43
5 kN·m	22.5	215	245	324	329	343	202.5	57	57
10 kN·m	28.5	263	293	373	377	391	226.5	58	58

10.4 Stator dimensions with the magnetic speed system

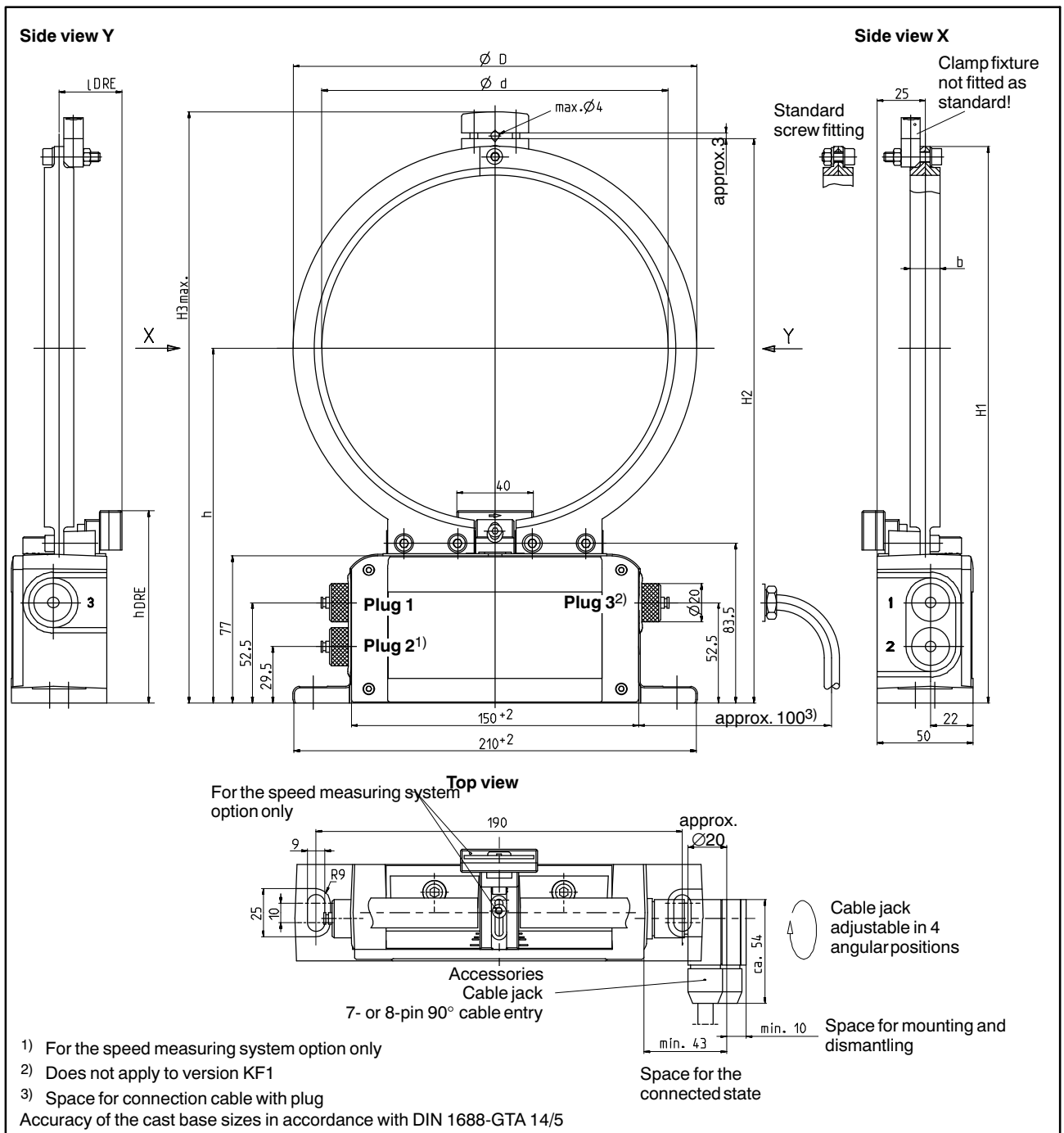

Measuring range	Dimensions (in mm)								
	b	Ød	Ø D	H1	H2	H3	h	l _{DRE}	h _{DRE} *)
100 (N·m) 200 (N·m)	17.5	125	155	235	239	253	157.5	38	100
500 (N·m) 1 kN·m	17.5	145	175	255	259	273	167.5	36	100
2 kN·m 3 kN·m	20.5	181	211	291	295	309	185.5	37	100
5 kN·m	22.5	215	245	325	329	343	202.5	51	105.5
10 kN·m	28.5	263	293	373	377	391	226.5	52	105.5

*) Variable by ± 1.5 mm at the head of the sensor

10.5 Mounting dimensions

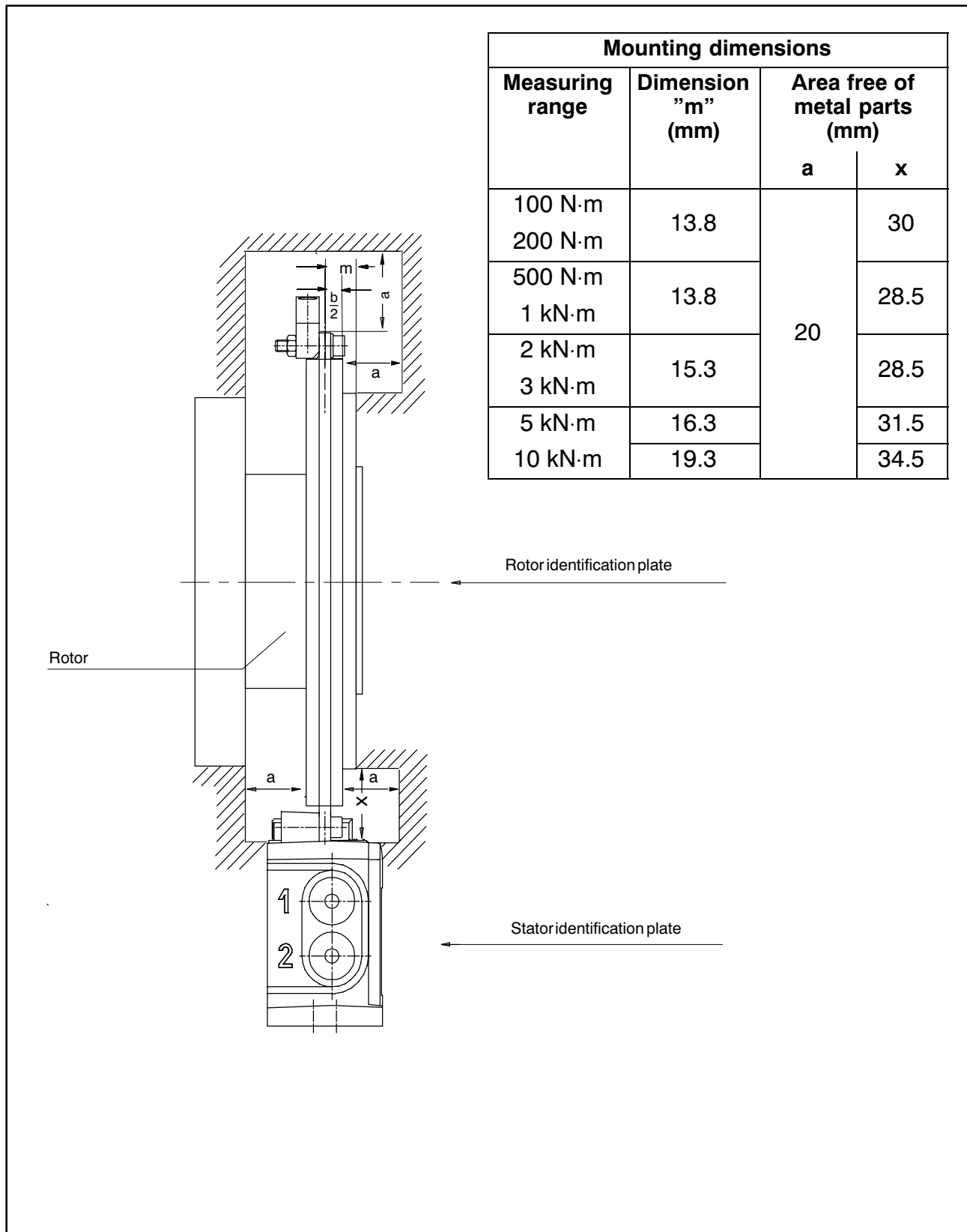

12 Specifications

Type		T10FS							
Accuracy class		0.05							
Torque measuring system									
Nominal (rated) torque M_{nom}	N·m	100	200	500	1 k	2 k	3 k	5 k	10 k
Nominal (rated) sensitivity (spread between torque = zero and nominal (rated) torque)									
Frequency output	kHz	5							
Voltage output	V	10							
Sensitivity tolerance (deviation of the actual output quantity at M_{nom} from the nominal (rated) sensitivity)									
Frequency output	%	± 0.1							
Voltage output	%	± 0.2							
Output signal at torque = zero									
Frequency output	kHz	10							
Voltage output	V	0							
Nominal (rated) output signal									
Frequency output at positive nominal (rated) torque	kHz	15 (5 V symmetrical ¹)/12 V asymmetrical ²)							
Frequency output at negative nominal (rated) torque	kHz	5 (5 V symmetrical ¹)/12 V asymmetrical ²)							
Voltage output at positive nominal (rated) torque	V	+10							
Voltage output at negative nominal (rated) torque	V	-10							
Load resistance									
Frequency output	kΩ	≥ 2							
Voltage output	kΩ	≥ 5							
Long-term drift over 48h									
Voltage output	mV	≤ ± 3							
Measurement frequency range									
Voltage output	Hz	0 ... 1000 (-3 dB)							
Group delay time									
Frequency output	ms	0.15							
Voltage output	ms	0.9							
Residual ripple									
Voltage output	mV	40 (peak-to-peak)							

¹) RS422 complementary signals; factory default version SF1/SU2

²) Factory default version KF1 (changeover not possible)

Specifications (continued)

Nominal (rated) torque M_{nom}	N·m	100	200	500	1 k	2 k	3 k	5 k	10 k
Thermal effects per 10 K in the nominal (rated) temperature range on the output signal, relative to the actual value of the signal spread									
Frequency output	%					< ±0.05			
Voltage output	%					< ±0.15			
on the zero signal, relative to the nominal (rated) sensitivity									
Frequency output	%					< ±0.05 (< ±0.03 optional)			
Voltage output	%					< ±0.15 (< ±0.13 optional)			
Maximum control range³⁾									
Frequency output	kHz					4 ... 16			
Voltage output	V					-10.5 ... +10.5 (typ. ±11)			
Power supply (version KF1)									
Excitation voltage (square wave)	V					54 ± 5% (peak-to-peak)			
Triggering the calibration signal	V					80 ± 5 %			
Frequency	kHz					approx. 14			
Max. current consumption	A					1 (peak-to-peak)			
Preamplifier excitation voltage	V					0/0/+15			
Preamplifier, max. current consumption	mA					0/0/+25			
Power supply (version SF1/SU2)									
Nominal (rated) supply voltage (separated extra-low voltage (SELV))	V(DC)					18 ... 30; asymmetrical			
Current consumption in measuring mode	A					< 0.9			
Current consumption in start-up mode	A					< 2			
Nominal (rated) power consumption	W					< 12			
Linearity deviation including hysteresis, relative to the nominal (rated) sensitivity									
Frequency output	%					< ±0.05 (< ±0.03 optional)			
Voltage output	%					< ±0.07 (< ±0.05 optional)			
Rel. standard deviation of reproducibility									
according to DIN 1319, relative to the variation of the output signal									
Frequency output	%	< ±0.03				< ±0.02			
Voltage output	%					< ±0.03			
Calibration signal									
Tolerance of the calibration signal, relative to M_{nom}	%								

³⁾ Output signal range with a repeatable interrelationship between torque and output signal.

Specifications (continued)

Nominal (rated) torque M_{nom}	N·m	100	200	500	1 k	2 k	3 k	5 k	10 k
Magnetic speed measuring system									
Rotation speed measuring system		Magnetic, by means of an MR (magneto-resistive) sensor and a magnetized plastic ring in the stainless steel ring. Multiplication by means of a real-time evaluation procedure							
Magnetic poles	No	120		144		180			
Pulse tolerance at evaluation factor 1 per pole at the factory default of the evaluation factor	Deg. Deg.	< 0.1 < 0.2 (typ. < 0.1)							
Pulses per revolution Possible settings ⁴⁾ (evaluation factor per pole)	No	120 (1); 480 (4); 600 (5); 960 (8); 1200 (10)		144 (1); 576 (4); 720 (5); 1152 (8); 1440 (10)		180 (1); 720 (4); 900 (5); 1440 (8); 1800 (10)			
Factory default	No	600 (5)		720 (5) ⁵⁾		720 (4)			
Possible settings through additional output pulse division ⁴⁾	No	10 ... 1200		12 ... 1440		15 ... 1800			
Output signal	V	5 ⁶⁾ symmetrical 2 square-wave signals, approx. 90° out-of-phase							
Maximum output frequency	kHz	250							
Minimum speed for sufficient pulse stability	min ⁻¹	0							
Group delay time	µs	< 5 (typ. 1.3)							
Hysteresis of reversal ⁷⁾ in the case of relative vibrations between the rotor and the stator	Deg.	< approx. 1							
Torsional vibration of the rotor	mm	< approx. 1							
Radial vibration amplitude of the stator									
Load resistance	kΩ	≥2 (note termination resistances as per RS422)							
Magnetic loading limit Remnant flux density	mT	> 100							
Coercive field strength	kA/m	> 100							
Permissible magnetic field strength for signal deviations per pole of < 0.1 degree	kA/m	< 0.1							
Radial nominal distance between sensor head and magnetic ring	mm	1.0				1.2			
Actuation distance range	mm	0.3 ... 1.8				0.3 ... 2.2			
Max. permissible radial shift of the rotor to the stator	mm	See actuation distance range; can be readjusted at the sensor head by ± 1.5 mm.							

4) When changing to higher output pulse factors, note the maximum possible output frequency of 250 kHz.

5) Max. permissible rotation speed for speed measurement is 20 500 min⁻¹. At higher speeds, less output pulses must be set.

6) RS422 complementary signals

7) Can be switched off

Specifications (continued)

Optical speed measuring system									
Nominal (rated) torque M_{nom}	N·m	100	200	500	1 k	2 k	3 k	5 k	10 k
Rotation speed measuring system		Optical, by means of infrared light and metallic slotted disc							
Mechanical increments	No	360						720	
Positional tolerance of the increments	mm	± 0.05							
Slot width tolerance	mm	± 0.05							
Pulses per revolution Electrically adjustable	No	360 ^{*)} ; 180; 90; 60; 30; 15						720; 360 ^{*)} ; 180; 90; 60; 30; 15	
Output signal	V	5 ⁸⁾ symmetrical, 2 square-wave signals, approx. 90° out-of-phase							
Minimum speed for sufficient pulse stability	min ⁻¹	2							
Group delay time	µs	< 5 (typ. 2.2)							
Hysteresis of reversal ⁹⁾ in the case of relative vibrations between the rotor and the stator Torsional vibration of the rotor Radial vibration amplitude of the stator	Deg. mm	< approx. 2 < approx. 2							
Load resistance	kΩ	≥ 2 (note termination resistances as per RS422)							
Permitted degree of pollution , in the optical path of the optical sensor (lenses, slotted disc)	%	< 50							
Measuring system reference pulse									
Measuring system		Magnetic, by means of a magnetoresistive sensor and a magnet synchronized with the rising ^{*)} or falling edge of the 0° output signal of the optical speed measuring system							
Output signal	V	5 symmetrical							
Pulse width		0.5 degree at 360 speed pulses/revolution (factory default)							
Number of pulses per revolution		1							
Minimum speed for sufficient pulse stability	min ⁻¹	2							
Group delay time	µs	< 5 (typ. 2.2)							
Additional phase error at < 20 min ⁻¹ > 20 min ⁻¹	Deg. Deg.	typ. < 0.1; leading negligible							
Reproducibility at 360 speed pulses/revolution	Deg.	typ. < ± 0.04 (ideal installation, operates without vibration)							

^{*)} Factory default

⁸⁾ RS422 complementary signals

⁹⁾ can be switched off

Specifications (continued)

General data										
Nominal (rated) torque M_{nom}	N·m	100	200	500	1 k	2 k	3 k	5 k	10 k	
EMC										
Emission (in accordance with EN61326-1, Table 4) RFI field strength	-	Class B								
Interference immunity (in accordance with EN61326-1, Table A.1)										
Electromagnetic field (AM)	V/m	10								
Magnetic field	A/m	30								
Electrostatic discharge (ESD)										
Contact discharge	kV	4								
	kV	8								
Air discharge	kV	1								
Rapid transients (burst)	kV	1								
Impulse voltages (surge)										
Conducted interference (AM)	V	3								
Degree of protection as per EN 60529										
IP54										
Weight, approx	Rotor	kg	1.9	1.9	2.4	2.4	4.9	4.9	8.3	14.6
	Stator	kg	1.2	1.2	1.2	1.2	1.3	1.3	1.3	1.3
Reference temperature	°C	+23								
Nominal (rated) temperature range	°C	+10...+60								
Operating temperature range	°C	-10...+60								
Storage temperature range	°C	-20...+70								
Impact resistance, test severity level according to DIN IEC 68; Part 2-27; IEC 68-2-27-1987										
Number	n	1000								
Duration	ms	3								
Acceleration (half-sine)	m/s ²	650								
Vibration resistance, test severity level according to DIN IEC 68, Part 2-6: IEC 68-2-6-1982										
Frequency range	Hz	5...65								
Duration	h	1.5								
Acceleration (amplitude)	m/s ²	50								

Specifications (continued)

Nominal (rated) torque		100	200	500	1 k	2 k	3 k	5 k	10 k	
Nominal (rated) speed	min ⁻¹	15 000		12 000				10 000	8 000	
Nominal (rated) speed optional	min ⁻¹	24 000		22 000		18 000		14 000	12 000	
Loading limits ¹⁰⁾										
Limit torque, relative to M_{nom}	%	400	200				160			
Breaking torque, relative to M_{nom}	%	>800	>400				>320			
Longitudinal force limit	kN	5	10	16	19	39	42	80	120	
Lateral force limit	kN	1	2	4	5	9	10	12	18	
Bending moment limit	N·m	50	100	200	220	560	600	800	1200	
Vibration bandwidth to DIN 50 100 (peak-to-peak)*)	N·m	400	400	1000	2000	4000	4800	8000	16 000	
Mechanical values										
Torsional stiffness c_T	kN·m /rad	270	270	540	900	2300	2600	4600	7900	
Torsion angle at M_{nom}	Deg.	0.022	0.043	0.055	0.066	0.049	0.066	0.06	0.07	
Stiffness in the axial direction c_a	kN/mm	800	800	740	760	950	1000	950	1600	
Stiffness in the radial direction c_r	kN/mm	290	290	550	810	1300	1500	1650	2450	
Stiffness during the bending moment round a radial axis c_b	kN·m /deg.	7	7	11.5	12	21.7	22.4	43	74	
Maximum excursion at longitudinal force limit	mm	<0.02		< 0.03		< 0.05		< 0.1		
Additional max. concentric error at lateral force limit	mm	< 0.02								
Additional plane/parallel deviation at bending moment limit	mm	< 0.03		< 0.05		< 0.07		< 0.07		
Balance quality level to DIN ISO 1940		G 2.5								

¹⁰⁾ Each type of irregular stress (bending moment, lateral or longitudinal force, exceeding nominal (rated) torque) can only be permitted up to its specified static loading limit, provided none of the others can occur at the same time. If this condition is not met, the limit values must be reduced. If 30% of the bending moment limit and lateral force limit occur at the same time, only 40% of the longitudinal force limit is permissible and the nominal (rated) torque must not be exceeded. The permissible bending moments, longitudinal forces and lateral forces can affect the measurement result by approx. 0.3% of the nominal (rated) torque.

*) With T10FS/200 N·m to 10 k N·m, the nominal (rated) torque must not be exceeded. With T10FS/100 N·m, the nominal (rated) torque may be exceeded by 100 %.

Specifications (continued)

Nominal (rated) torque		100	200	500	1 k	2 k	3 k	5 k	10 k
Max. permissible rotor vibration amplitude (peak-to-peak)¹¹⁾	μm	$s_{\max} = \frac{4500}{\sqrt{n}}$ (n in min ⁻¹)							
Mass moment of inertia of the rotor									
I_V (around axis of rotation)	kg·m ²	0.0026	0.0059			0.0192		0.0370	0.0970
I_V with optical speed measuring system	kg·m ²	0.0027	0.0062			0.0196		0.0380	0.0995
I_V with magnetic speed measuring system	kg·m ²	0.0029	0.0065		0.0203	0.0201		0.0390	0.1
Max. permissible static eccentricity of the rotor (radially) to the center point of the stator									
without the speed module	mm					± 2			
with the optical speed module (with or without a reference pulse)	mm					± 1			
with the magnetic speed module	mm					± 0,7			
Permissible axial displacement between rotor and stator									
without the speed module									
with the optical speed module (with or without a reference pulse)	mm					± 3			
with the magnetic speed module	mm					± 2			
	mm					± 1,5			

¹¹⁾ Relative undulation in the connection flange area, following DIN 45670/VDI 2059

13 Supplementary technical information

13.1 Output signals

13.1.1 Output MD torque (plug 1)

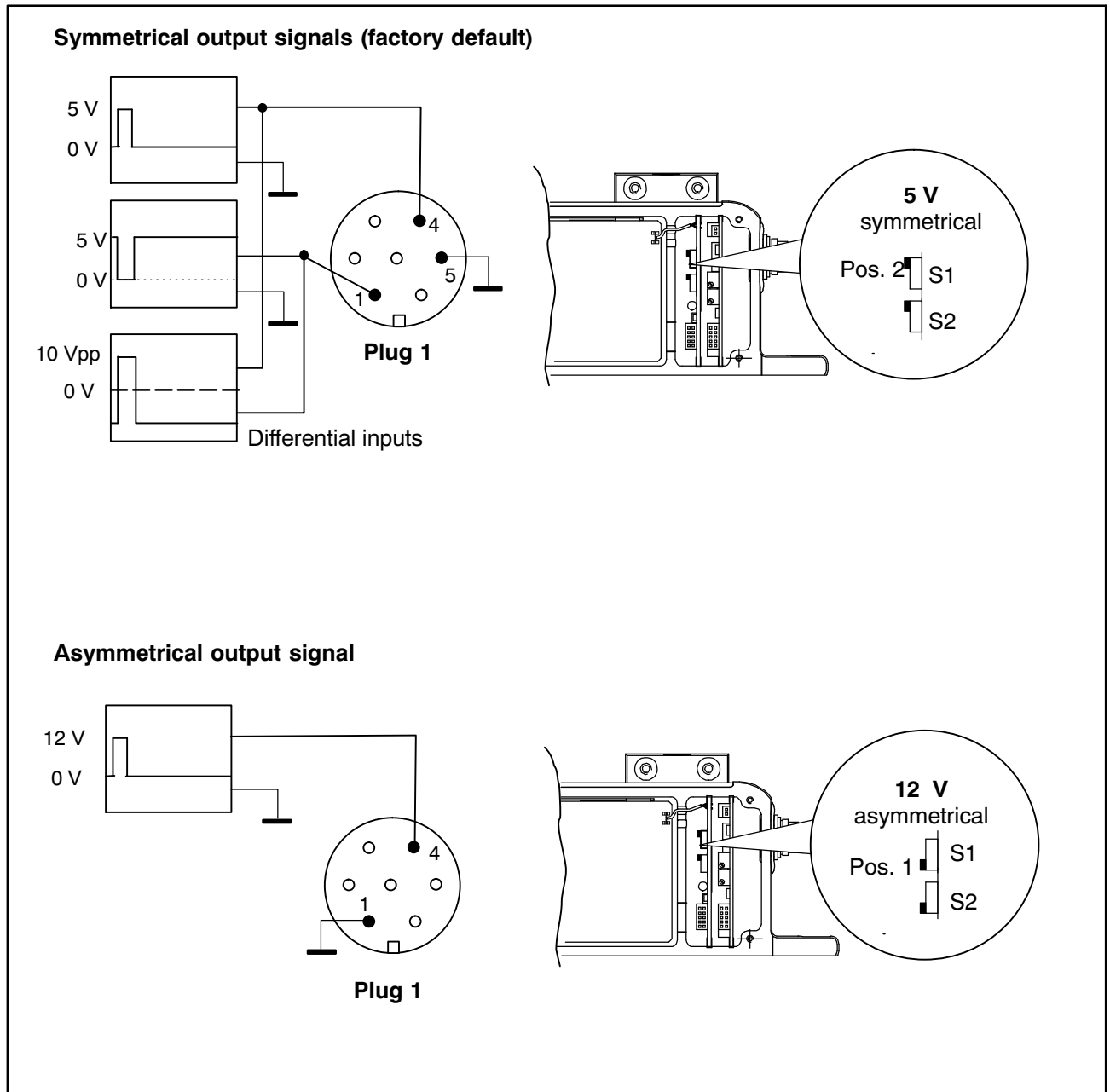

13.1.2 Output N: Speed and speed with a reference pulse (plug 2)

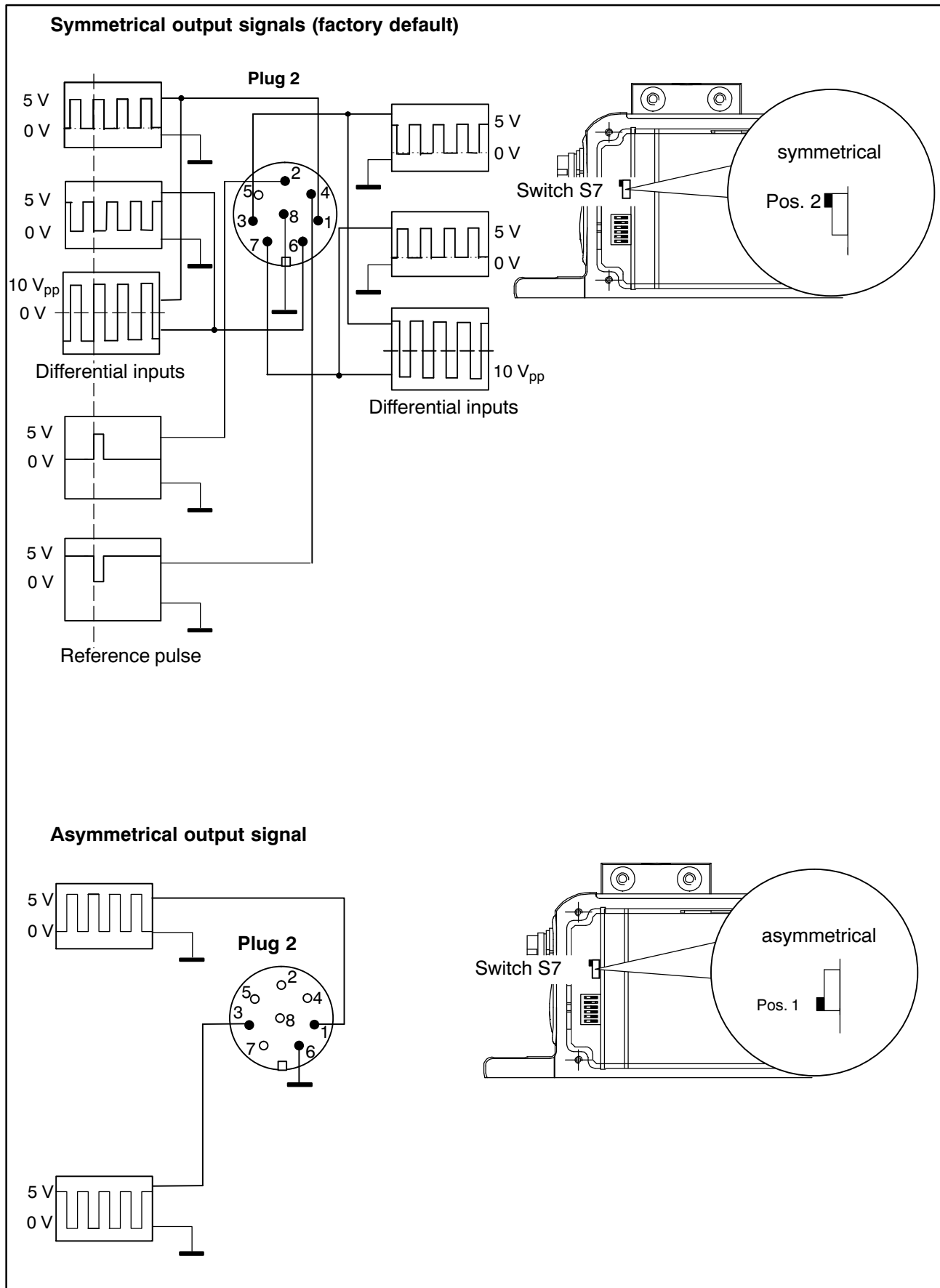

13.1.3 Plug 2, double frequency, stat. direction of rotation signal

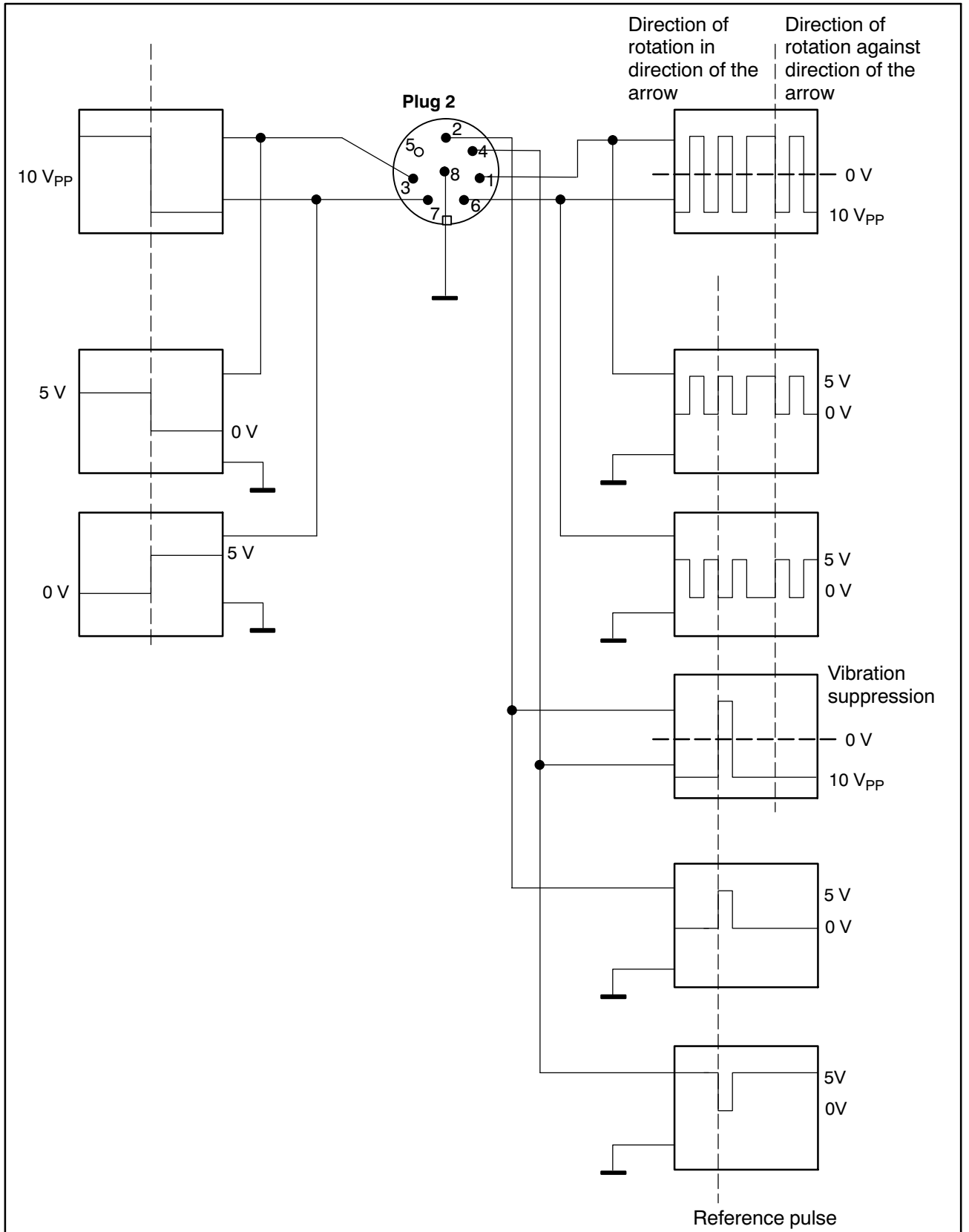

13.2 Circular run-out values

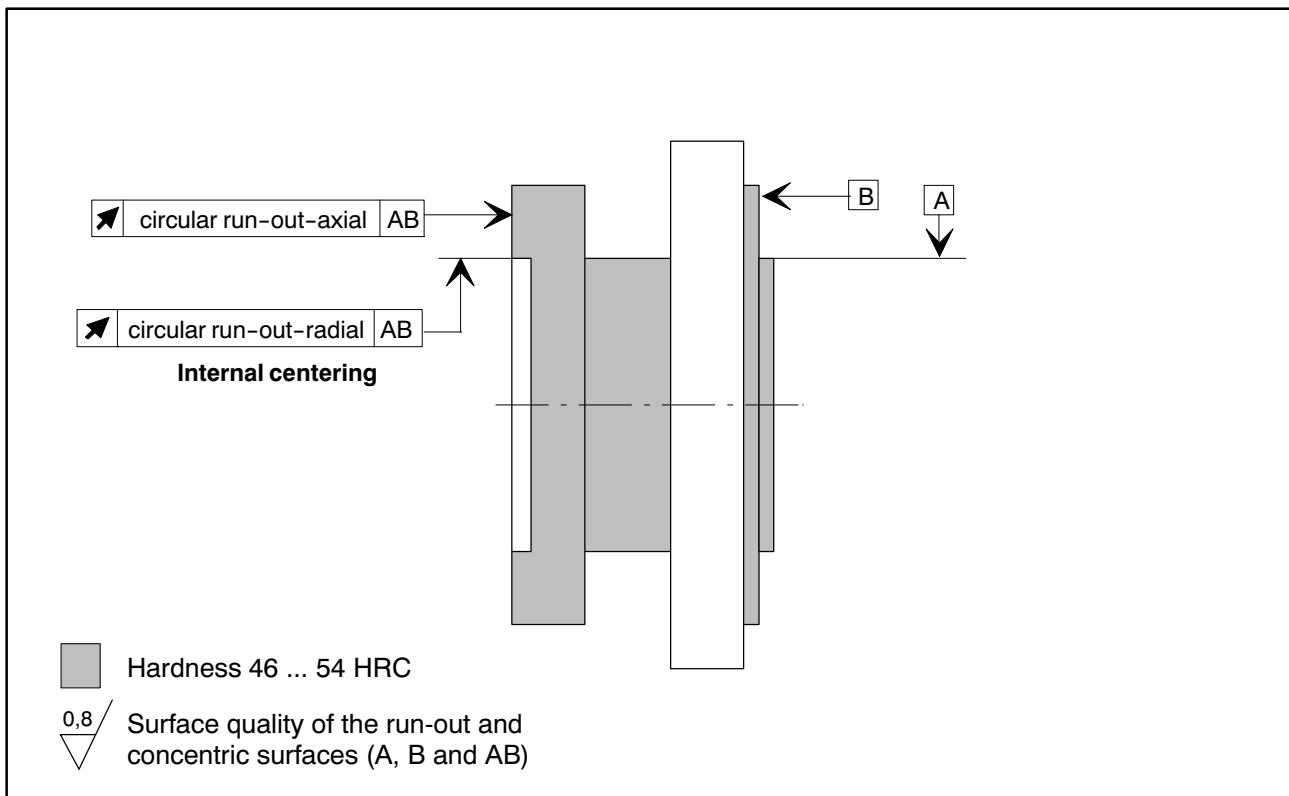

Measuring range	circular run-out-axial tolerance (mm)	circular run-out-radial tolerance (mm)
100 N·m	0.01	0.01
200 N·m	0.01	0.01
500 N·m	0.01	0.01
1 kN·m	0.01	0.01
2 kN·m	0.02	0.02
3 kN·m	0.02	0.02
5 kN·m	0.02	0.02
10 kN·m	0.02	0.02

To ensure that the torque flange retains its characteristics once it is installed, we recommend that the customer also chooses the specified form and position tolerances, surface quality and hardness for the connections provided.

Modifications reserved.
All details describe our products in general form only. They are not to be understood as express warranty and do not constitute any liability whatsoever.

7-2002.1315

Hottinger Baldwin Messtechnik GmbH

Postfach 10 01 51, D-64201 Darmstadt

Im Tiefen See 45, D-64293 Darmstadt

Tel.: +49 6151 803-0 Fax: +49 6151 8039100

Email: support@hbm.com Internet: www.hbm.com



A0785-12.1 en

measurement with confidence